

Project Title :PROPOSED RESIDENTIAL BUILDING OF MR. KUNAL TIWARI

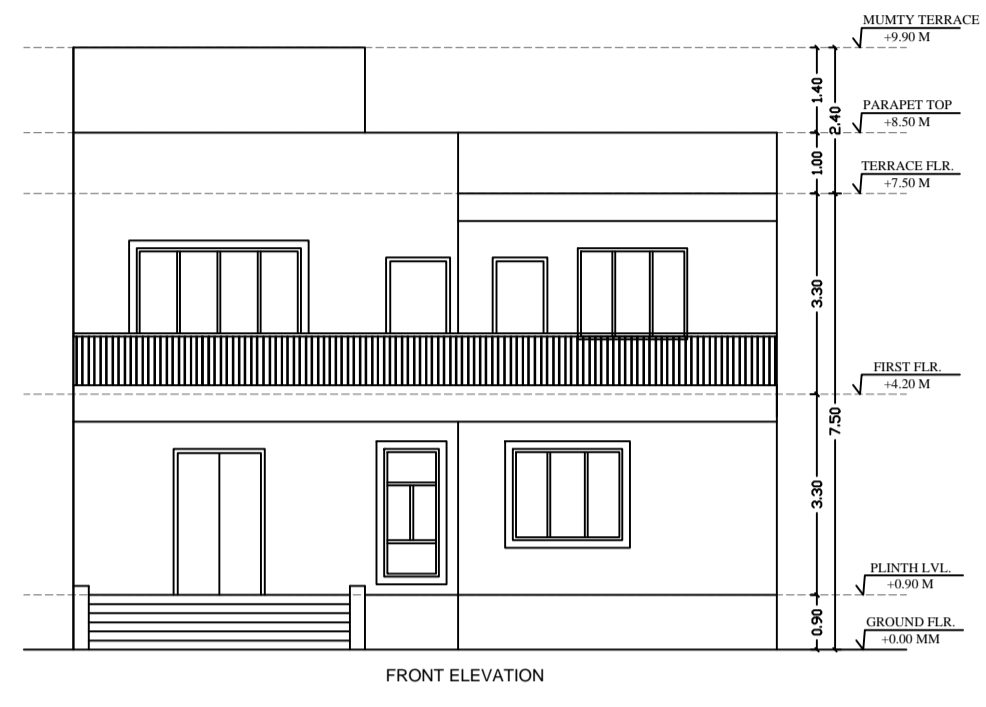

Elevation 1 Detail

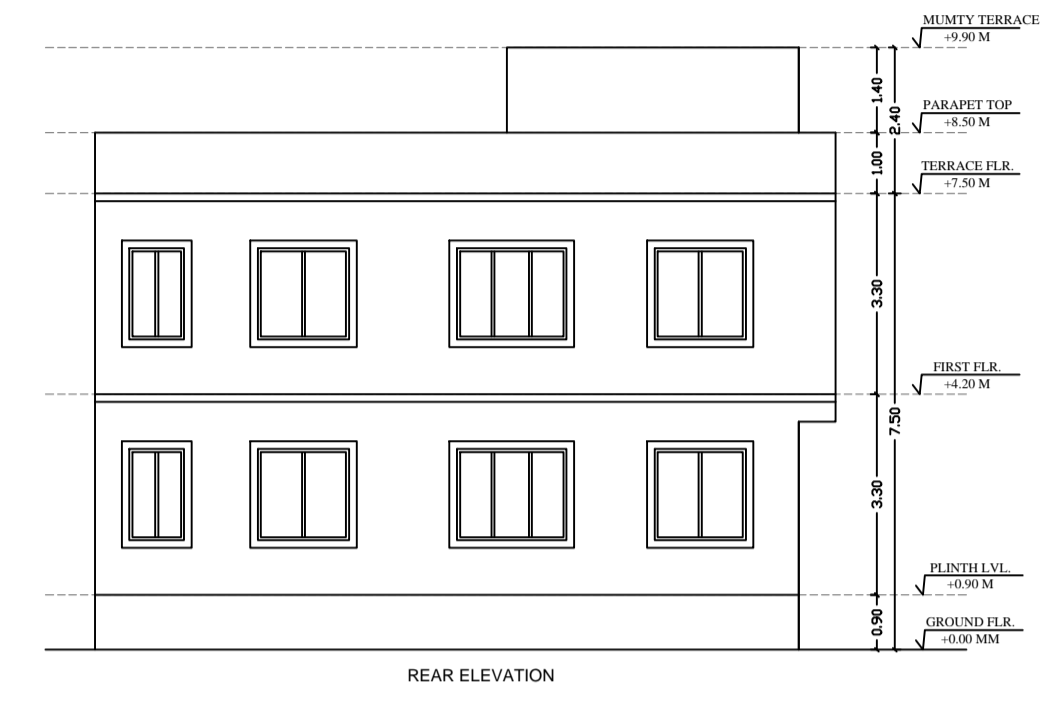

Elevation 2 Detail

**CERTIFICATE FOR STRUCTURE SAFETY**  
 THIS IS CERTIFY THAT THE STRUCTURAL DESIGN OF THE BUILDING WILL BE AS PER I.S-1983-1984 & I.S.4326-1993 TO MAKE SAME EARTH QUAKE RESISTANT.

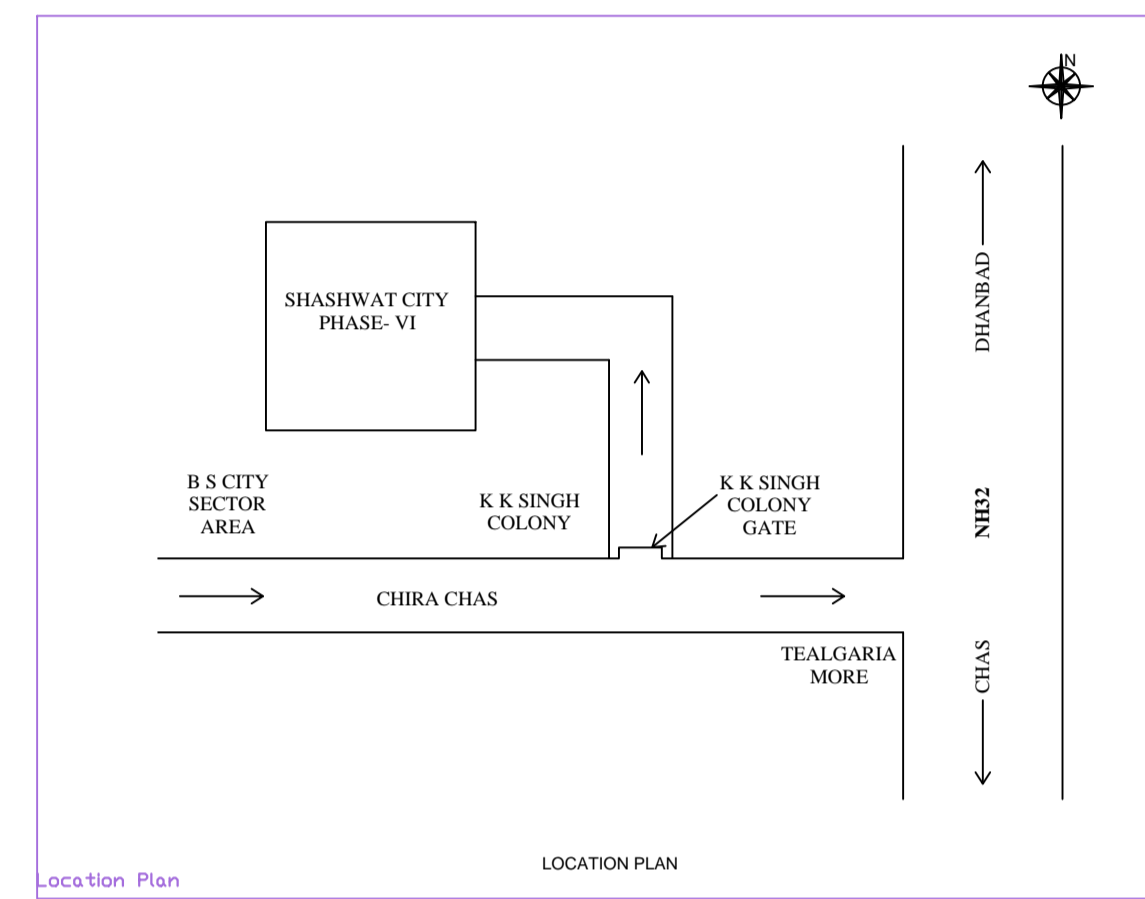

Location Plan

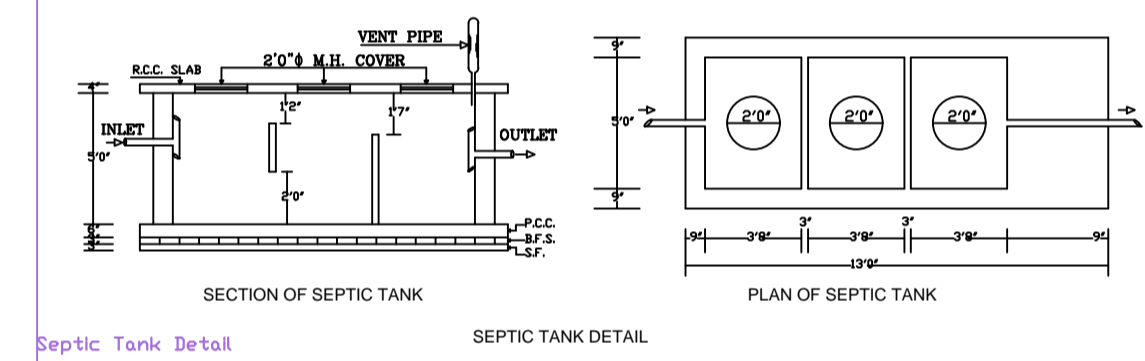

Septic Tank Detail

AREA STATEMENT: CHAS MUNICIPAL CORPORATION	VERSION NO: 1.0.24
PROJECT DETAIL:	VERSION DATE: 01/01/2019
Inward No. :-	Plot Use: Residential
Region :-BHARKHAND URBAN LOCAL BODIES	Plot SubUse: Bungalow Dwelling / Non Apartment
District :-BOKARO	Land Use Zone: Residential
Application Type: General Proposal	Abutting Road Width: -
Project Type: Building Permission	Plot No: 1402
Nature of Development: New	Revenue Survey No/Survey No: -
Location: Old Area	Thana No: 30
Sub Location: NA	Holding No: -
Village/Mauza Name: CHAS	Khata No: 584
Ward No: 04	North: -
Road/Street: -	South: -
	East: -
	West: -

AREA DETAILS:		SQ.MT.
AREA OF PLOT (Minimum)	(A)	348.39
Net Plot Area (Gross Plot Area - Deductions from Gross Plot Area)	(A-Deductions)	348.39
Deductions for Balance Plot Area (from Gross Plot Area)		38.54
COP Area		38.54
Total		38.54
Balance Plot Area (Net Plot Area - Recreational/Amenity spaces)	(A-Deductions)	309.85
Plot Area for Coverage (Net Plot Area)	(A-Deductions)	348.39
Plot Area for FSI (Net Plot Area - Road/Widening Area)	(A-Deductions)	348.39

COVERAGE CHECK		
Proposed Coverage Area ( 44.55 % )		155.20
Total Coverage Area ( 44.55 % )		155.20
FAR CHECK		
Proposed Area of FAR		293.98
Total Area of FAR		293.98
BUILT UP AREA CHECK		
Total Proposed BuiltUp Area		297.13
ARCH / ENGGT SUPERVISOR (Regd)	OWNER	
DEVELOPMENT AUTHORITY	LOCAL BODY	

Color Index

ABUTTING ROAD	
PROPOSED WORK (COVERAGE AREA)	
EXISTING (To be retained)	
EXISTING (To be demolished)	

FAR & Tenement Details (Table 4c-1)

Building	No. of Same Bldg	Gross Built Up Area (Sq.m)	Deductions From Gross BUA/Area m (Sq.m)	Total Built Up Area (Sq.m)	Deductions (Area in Sq.m)	Proposed FAR Area (Sq.m)	Total FAR Area (Sq.m)	Tnmt (No.)
A (A)	1	319.46	22.33	297.13	3.15	293.98	293.98	01
Grand Total:	1	319.46	22.33	297.13	3.15	293.98	293.98	01

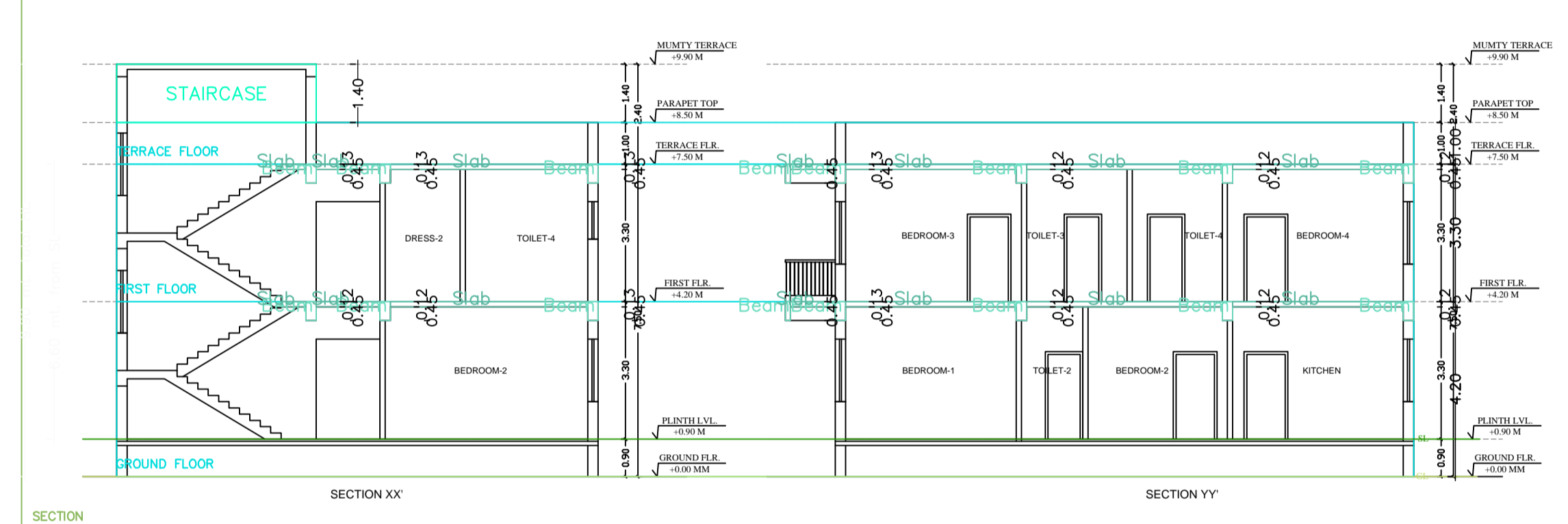
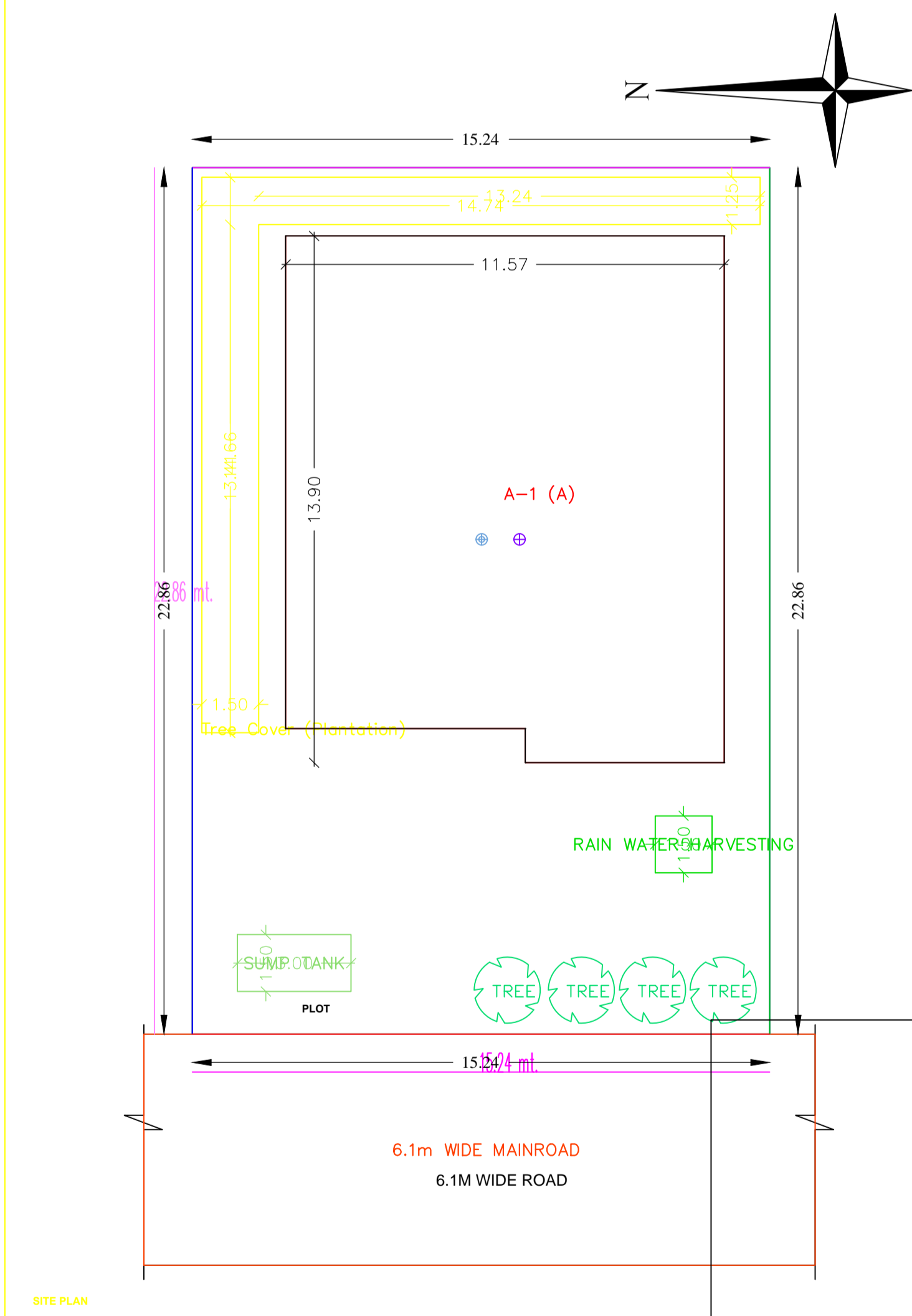

SECTION

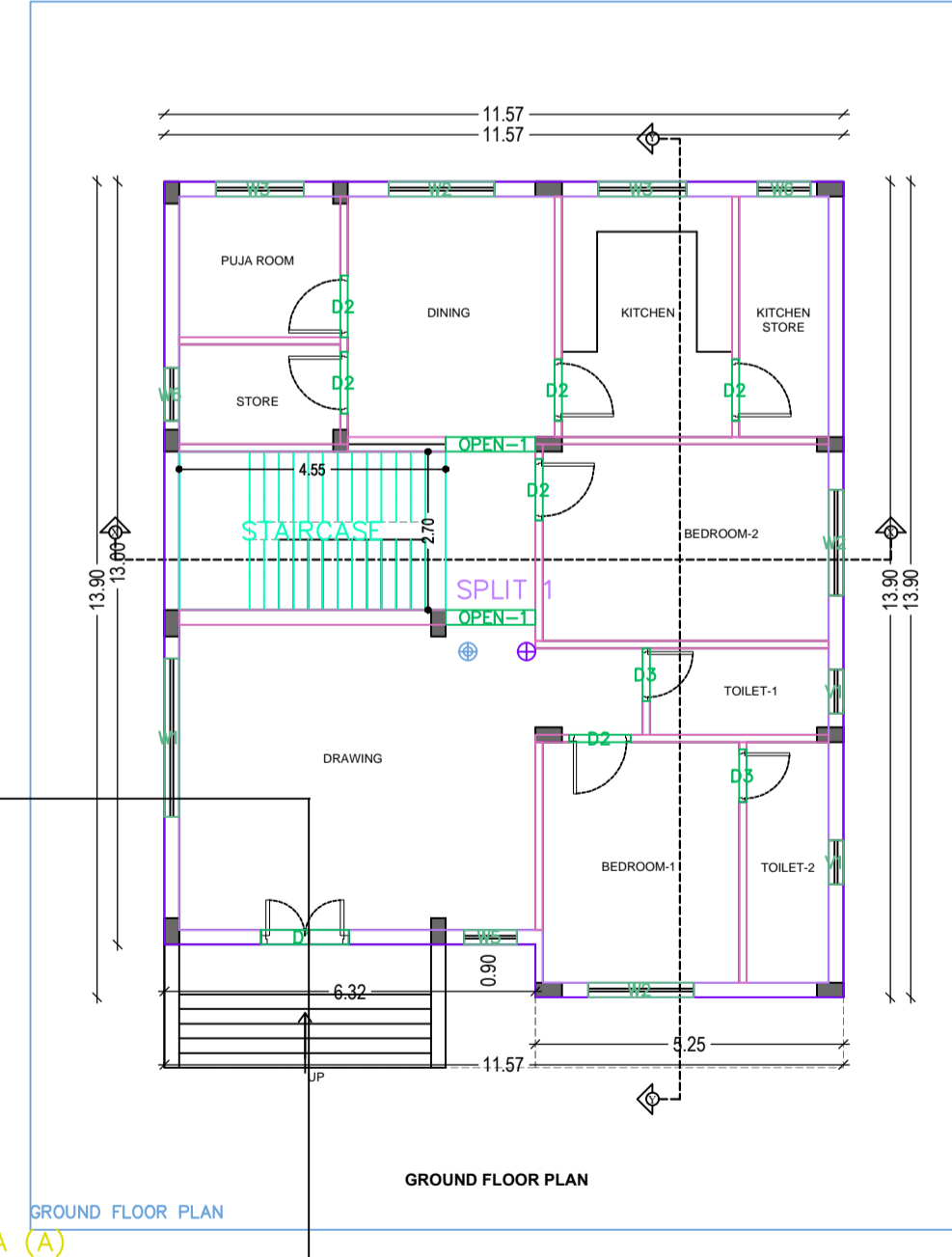

GROUND FLOOR PLAN

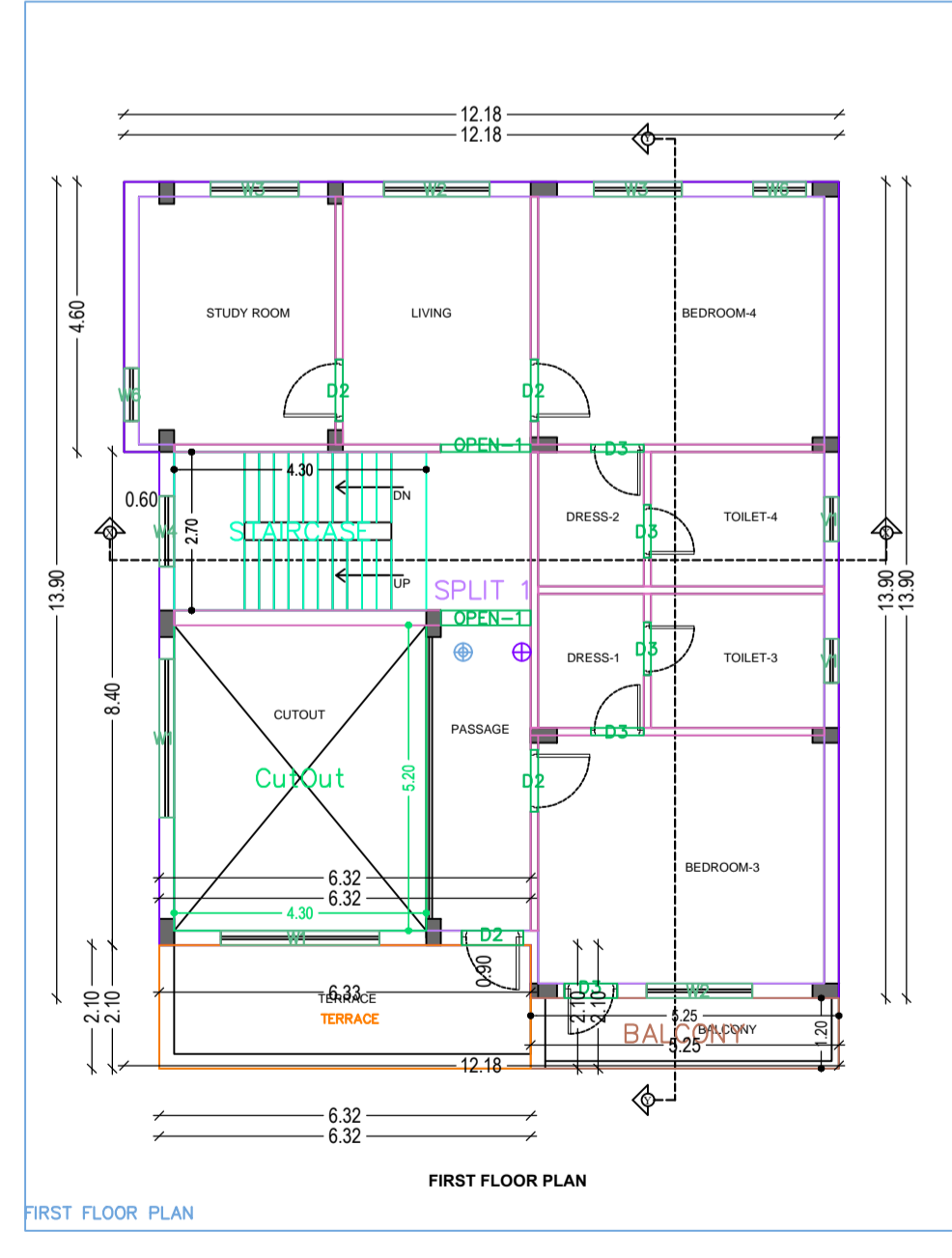

FIRST FLOOR PLAN

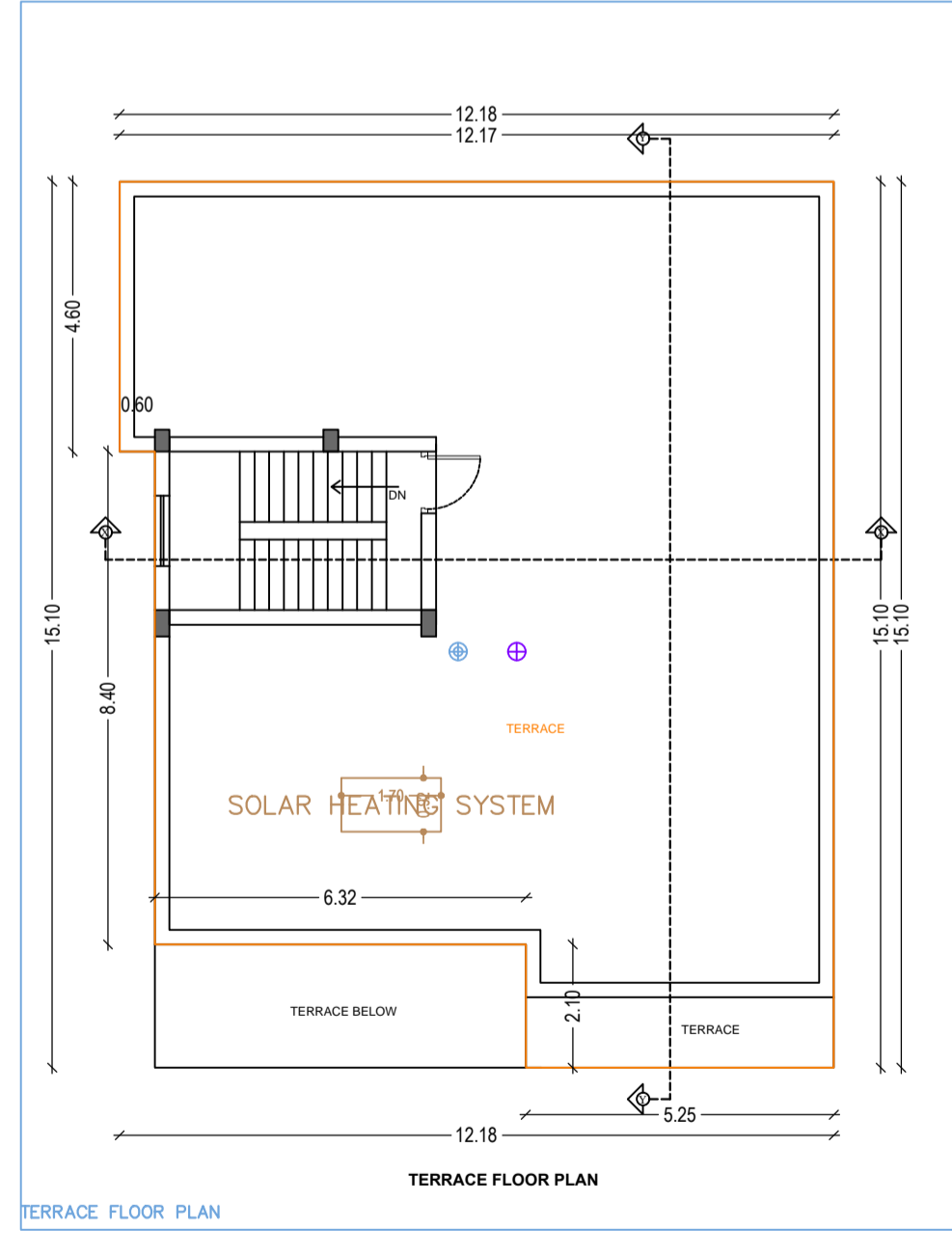

TERRACE FLOOR PLAN

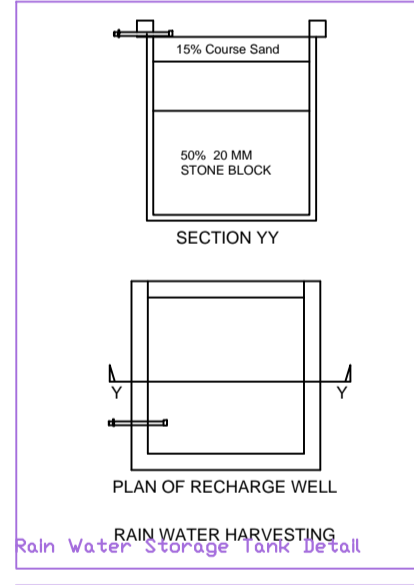

RAIN WATER HARVESTING

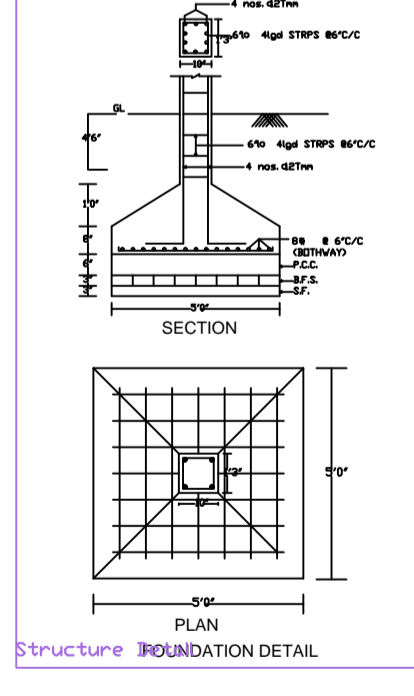

Structure FOUNDATION DETAIL

Building :A (A)