

FRONT ELEVATION

SIDE ELEVATION

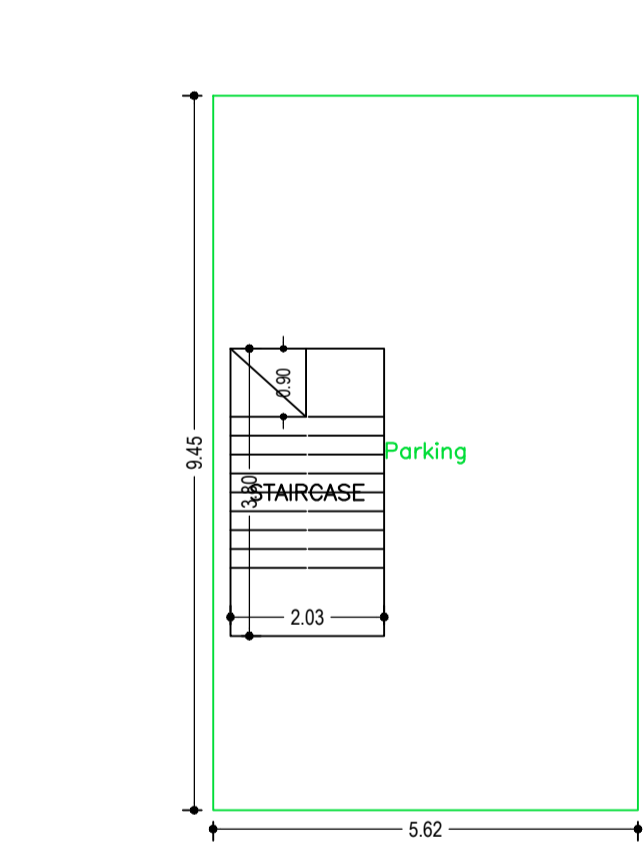

GROUND FLOOR PLAN (SCALE 1:100)

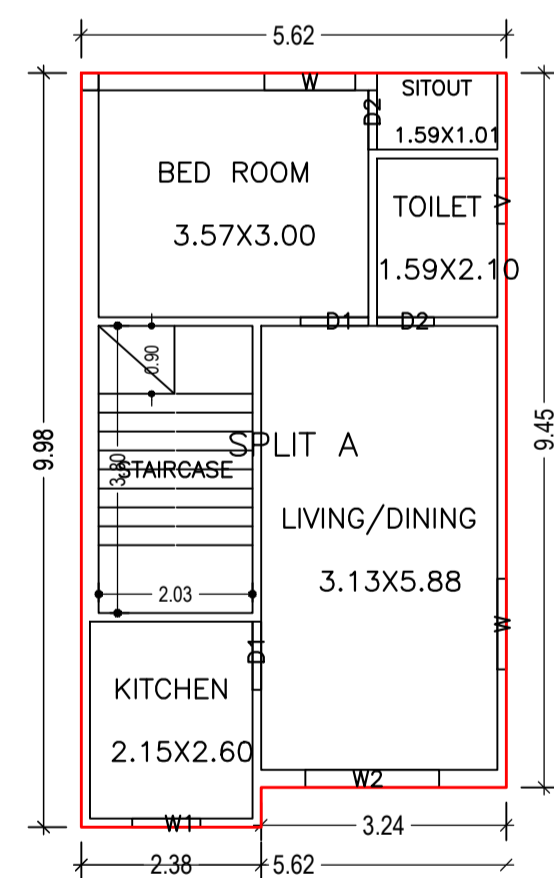

FIRST FLOOR PLAN (Proposed) (SCALE 1:100)

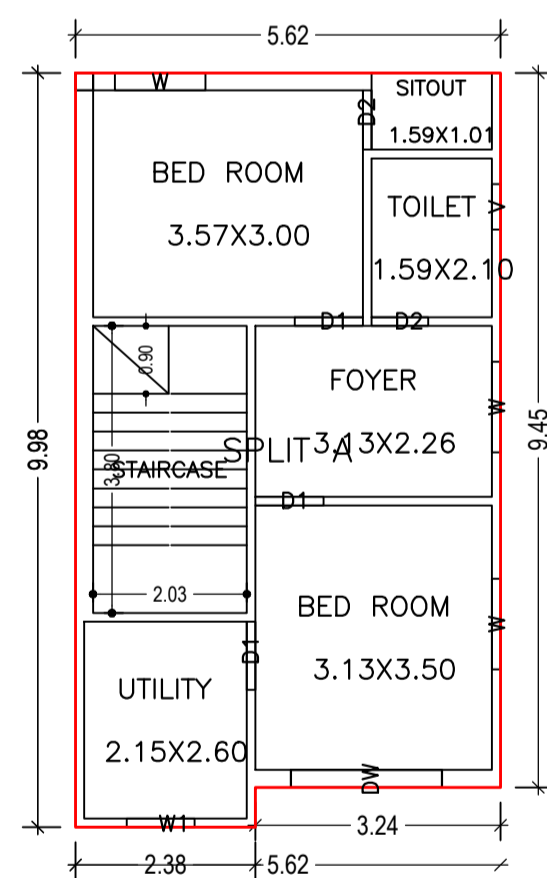

SECOND FLOOR PLAN (Proposed) (SCALE 1:100)

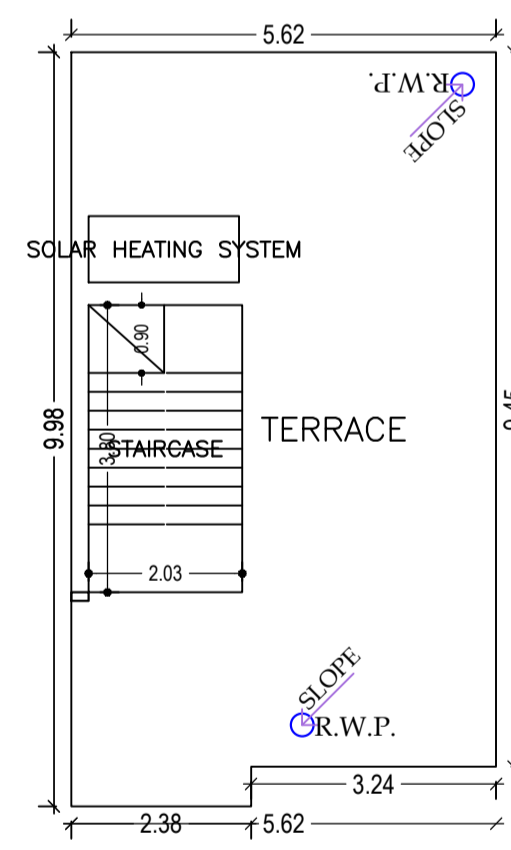

TERRACE FLOOR PLAN (SCALE 1:100)

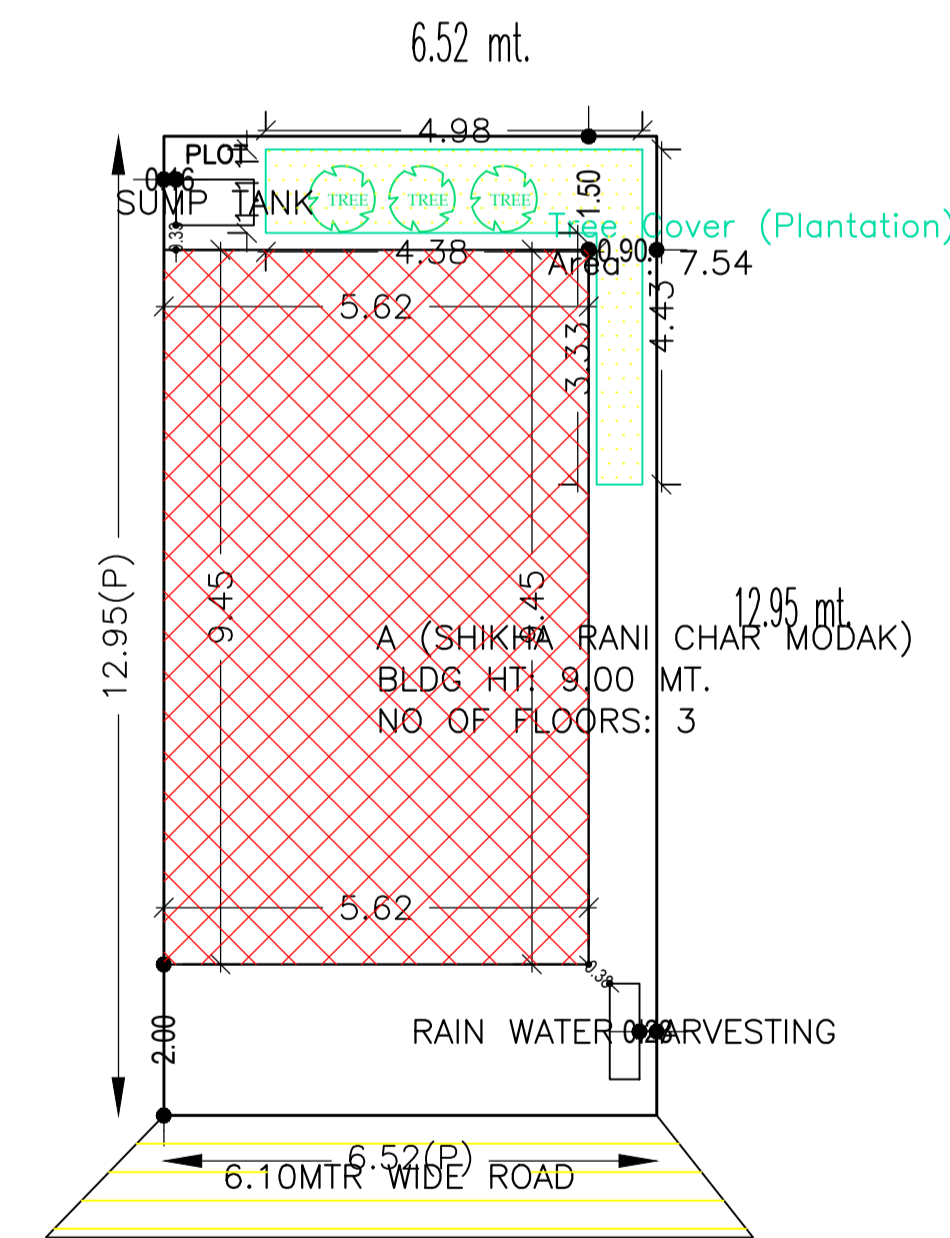

SITE PLAN

Building :A (SHIKHA RANI CHAR MODAK)

Floor Name	Total Built Up Area (Sq.mt.)	Deductions (Area in Sq.mt.)		Proposed FAR Area (Sq.mt.)	Add Area in FAR (Sq.mt.)	Total FAR Area (Sq.mt.)	Total Consumed Additional FAR Area (Sq.mt.)	Tnmt (No.)
		Parking	Resi.					
Ground Floor	53.11	45.38	0.00	7.73	7.73	7.73	0.00	00
First Floor	54.36	0.00	54.36	0.00	54.36	54.36	0.00	01
Second Floor	54.36	0.00	54.36	0.00	54.36	54.36	0.00	00
Terrace Floor	0.00	0.00	0.00	0.00	0.00	0.00	0.00	00
Total	161.83	45.38	108.72	7.73	116.45	116.45	0.00	01
Total Number of Same Buildings	1							
Total	161.83	45.38	108.72	7.73	116.45	116.45	0.00	01

Building USE/SUBUSE Details

Building Name	Building Use	Building SubUse	Building Structure
A (SHIKHA RANI CHAR MODAK)	Residential	Bungalow/ Dwelling / Non Apartment	Non-Highrise

Color	Description
Black	PLOT BOUNDARY
Red	ABUTTING ROAD
Green	PROPOSED CONSTRUCTION
Blue	COMMON PLOT
Yellow	ROAD WIDENING AREA
Light Blue	EXISTING (To be retained)
Light Green	EXISTING (To be demolished)

FAR & Tenement Details (Table 4c-1)

Building	No. of Same Bldg	Total Built Up Area (Sq.mt.)	Deductions (Area in Sq.mt.)	Proposed FAR Area (Sq.mt.)	Add Area in FAR (Sq.mt.)	Total FAR Area (Sq.mt.)	Total Consumed Additional FAR Area (Sq.mt.)	Tnmt (No.)
A (SHIKHA RANI CHAR MODAK)	1	161.83	45.38	108.72	7.73	116.45	116.45	01
Grand Total :	1	161.83	45.38	108.72	7.73	116.45	116.45	01

LTP NAME AND SIGNATURE	STRUCTURAL ENG'S NAME AND SIGNATURE	BUILDER NAME AND SIGNATURE	DIGITAL SIGNATURE
DINABANDHU RAJAK CMC/ENG/001/2020			

Proposal Basic Information	
Proposal File No.	CMC/BP/0185/W02/2021
Owner Name	SHIKHA RANI CHAR MODAK
Khata No	307
Plot No	187,189,190,191
Village Name	Chas
Use	Residential
SubUse	Bungalow/ Dwelling / Non Apartment

AREA STATEMENT CHAS MUNICIPAL CORPORATION		VERSION NO. : 1.0.60
PROJECT DETAIL:		VERSION DATE: 16/10/2020
Region: JHARKHAND URBAN LOCAL BODIES	Plot Use: Residential	SQ.MT.
District: BOKARO	Plot SubUse: Bungalow/ Dwelling / Non Apartment	
Authority: CHAS MUNICIPAL CORPORATION	PlotNearbyReligiousStructure: NA	
Inward No: CMC/BP/0185/W02/2021	PlotSubPlot No: 187,189,190,191	
Application Type: General Proposal	North: CTS No. - NIJ	
Project Type: Building Permission	South: CTS No. - NIJ	
Nature of Development Area: New	East: Road Width - 6.10 MTR WIDE ROAD	
Location of Development Area: Old Area	West: CTS No. - BOUNDARY WALL	
AREA DETAILS:		
AREA OF PLOT (Minimum)	(A)	84.43
NET AREA OF PLOT(Gross Plot Area - Deduction from Gross Plot area)	(A-Deductions)	84.43
Deduction for Balance Plot Area(from Gross Plot Area)		
Common Plot		7.54
Total		7.54
BALANCE AREA OF PLOT(Net Plot Area - Recreational/Amenity space)	(A-Deductions)	76.90
PLOT AREA FOR COVERAGE(Net Plot Area)	(A-Deductions)	84.43
Plot Area for FAR (Net Plot Area + Road/Widening Area)	(A-Deductions)	84.43
COVERAGE CHECK		
Permissible Coverage area ( 70.00 % )		59.10
Proposed Coverage Area ( 62.90 % )		53.11
Total Prop. Coverage Area ( 62.9 % )		53.11
Balance coverage area ( 7.09 % )		5.99
FAR CHECK		
Perm. FAR Area ( 2.50 )		211.07
Total Perm. FAR area		211.07
Residential FAR		108.72
Proposed FAR Area		116.44
Total Proposed FAR Area		116.44
Consumed FAR (Factor)		1.38
Balance FAR Area		94.63
BUILT UP AREA CHECK		
Total Proposed BuiltUp Area		161.83
ARCHITECT (Regd)		DINABANDHU RAJAK
ENGINEER (Regd)		
SUPERVISOR (Regd)		
OWNER (Regd)		SHIKHA RANI CHAR MODAK
DEVELOPMENT AUTHORITY		LOCAL BODY

Buildingwise Floor FAR Details

Floor Name	Building Name		Total	
	A (SHIKHA RANI CHAR MODAK) Proposed Built Up Area (Sq.mt.)	Proposed FAR Area (Sq.mt.)	Total Proposed Built Up Area (Sq.mt.)	Total FAR Area (Sq.mt.)
Ground Floor	53.11	7.73	53.11	7.73
First Floor	54.36	54.36	54.36	54.36
Second Floor	54.36	54.36	54.36	54.36
Terrace Floor	0.00	0.00	0.00	0.00
Total :	161.83	116.45	161.83	116.45

UnitBUA Table for Building :A (SHIKHA RANI CHAR MODAK)

FLOOR	Name	UnitBUA Type	UnitBUA Area	Carpet Area	No. of Rooms	No. of Tenement
FIRST FLOOR PLAN	SPLIT A	FLAT	108.72	108.61	5	1
SECOND FLOOR PLAN	SPLIT A	FLAT	0.00	0.00	6	0
Total :	-	-	108.72	108.61	11	1

SCHEDULE OF DOOR:

BUILDING NAME	NAME	LENGTH	HEIGHT	NOS
A (SHIKHA RANI CHAR MODAK)	D2	0.75	2.10	02
A (SHIKHA RANI CHAR MODAK)	D2	0.79	2.10	02
A (SHIKHA RANI CHAR MODAK)	D1	0.90	2.10	05

SCHEDULE OF WINDOW/VENTILATION:

BUILDING NAME	NAME	LENGTH	HEIGHT	NOS
A (SHIKHA RANI CHAR MODAK)	V	0.60	1.20	02
A (SHIKHA RANI CHAR MODAK)	W1	0.90	1.20	02
A (SHIKHA RANI CHAR MODAK)	W	1.20	1.20	05
A (SHIKHA RANI CHAR MODAK)	W2	1.77	1.20	01
A (SHIKHA RANI CHAR MODAK)	DW	2.00	2.10	01