

Project Title : 1 ANITA KUMARI SINGH W/O- SATYENDRA KUMAR SINGH 2. SATYENDRA KUMAR SINGH S/O- LATE CHANDRAKETU SINGH

AREA STATEMENT CHAS MUNICIPAL CORPORATION	VERSION NO. 1.0.0
PROJECT DETAILS	VERSION DATE: 08/10/2023
Town No. :	Plot No. Residential
Region : ANANDWADI URBAN LOCAL BODIES	Plot Location : Bungalow Dwelling / New Apartment
PROJECT BOUNDARY	Level Code Zone : 1st
Application Type : General Proposal	Building Height : -
PROJECT TYPE : Building Permission	Plot No. :
Nature of Development : New	Recent Survey No/Scale No. :
Location : -	Name : -
Site Location : -	Plotting No. : -
Village/Moosa Name : -	Phase No. : -
Ward No. : -	Name : -
RoadSheet : -	Scale : -
Site : -	Water : -

TABLES (M ²)		SCAFF
NET PLOT Area (Minimum)	(A)	84.43
NET PLOT Area (Gross Plot Area - Deductions from Gross Plot area)	(A-Deductions)	84.43
Deduction for Balance Plot Area (from Gross Plot Area)		
CSP Area		7.64
Total		7.64
Balance Plot Area (Net Plot Area - Deductions/Amounts open)	(A-Deductions)	76.79
Plot Area for Coverage (Net Plot Area)	(A-Deductions)	84.43
Plot Area for STP (Net Plot Area + Sloping/Retaining Area)	(A-Deductions)	84.43
COVERAGE CHECK		
Proposed Coverage Area (82.50 %)		53.11
Plot Coverage Area (82.50 %)		53.11
FAR CHECK		
Proposed Area of FAR		118.84
Maximum FAR		118.84
BUILT UP AREA CHECK		
Total Proposed Built Up Area		106.61
ALLOT TENDER SUPERSEDED (If any)		OWNER
DEPARTMENT AUTHORITY LOCAL BODY		

COLOR INDEX	
ABUTTING ROAD	Black
PROPOSED WORK (COVERAGE AREA)	Green
EXISTING (To be retained)	Blue
EXISTING (To be demolished)	Yellow

PARKING CALCULATION		
Parking Type	Prop No.	Prop Area
Other Parking	1	45.38
Total Area		45.38

MARGIN DETAIL					
Building Width	Road Name	Front Margin	Rear Margin	Side Margin	Side Margin
A (ANITA AND SATYENDRA)	4' (OTHER WORK ROAD)	2.00	1.00	0.00	0.00

FAR & Setback Details (Table 40-1)								
Building	No. of Same Bldg	Type Bldg (Sq.Mt.)	Deductions (Area in Sq.Mt.)	Proposed FAR Area (Sq.Mt.)	Total FAR Area (Sq.Mt.)	Threat No.		
A (ANITA AND SATYENDRA)	1	106.61	2.39	45.38	111.11	7.73	118.84	01
Grand Total	1	106.61	2.39	45.38	111.11	7.73	118.84	01

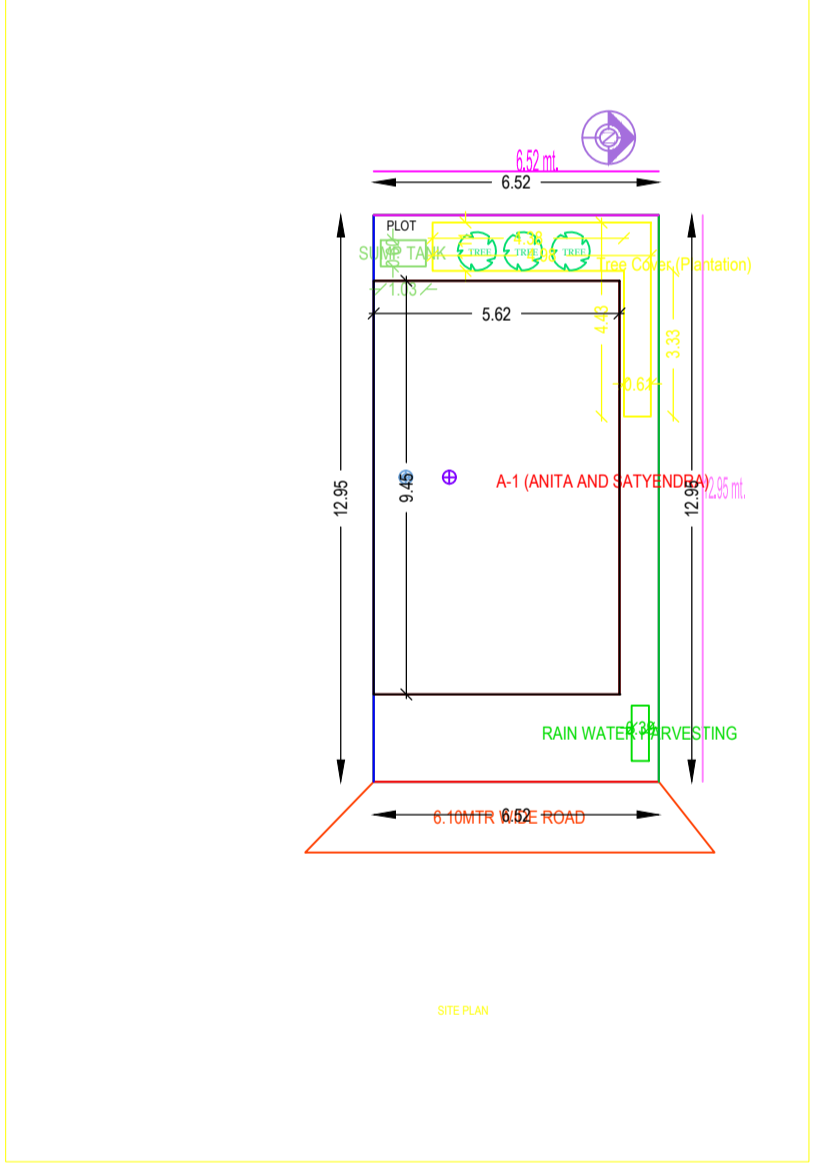
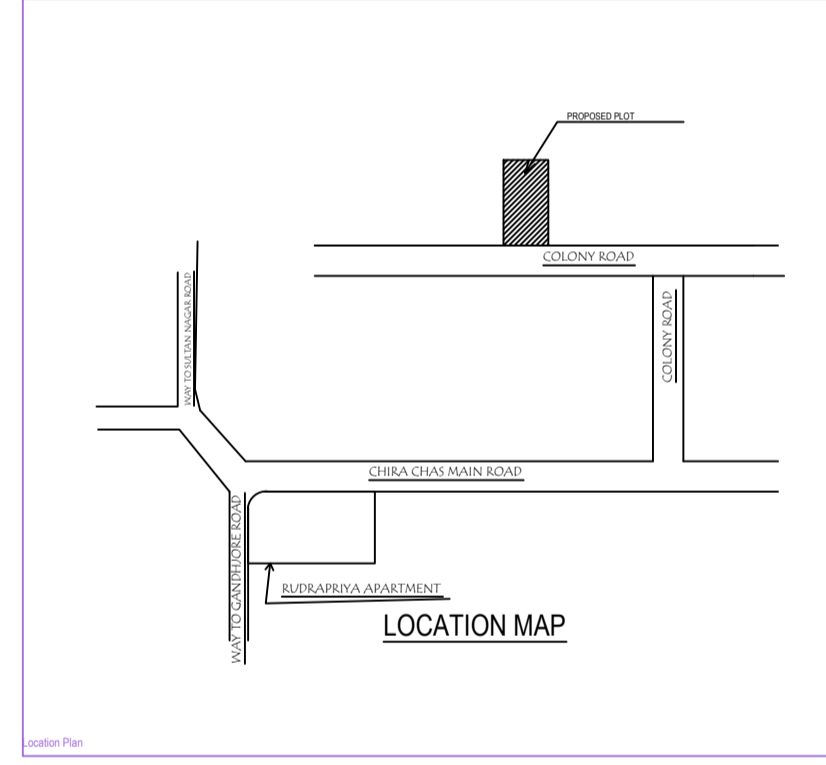
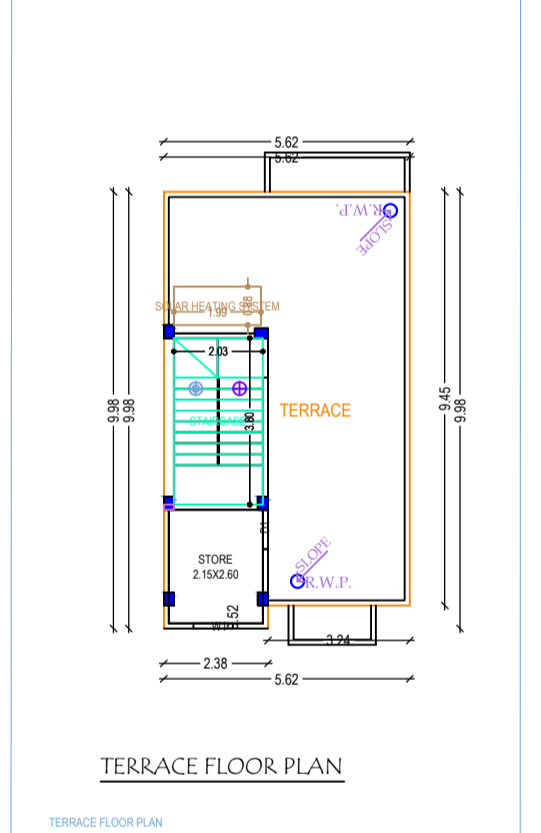
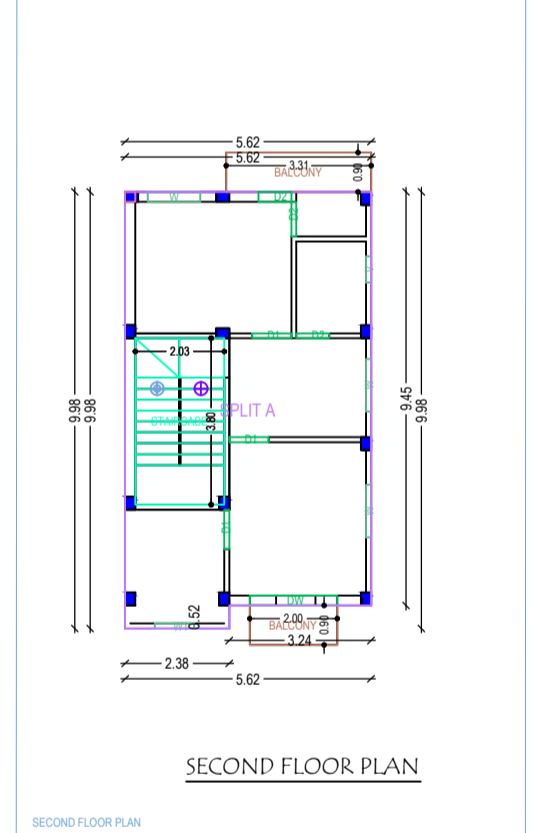
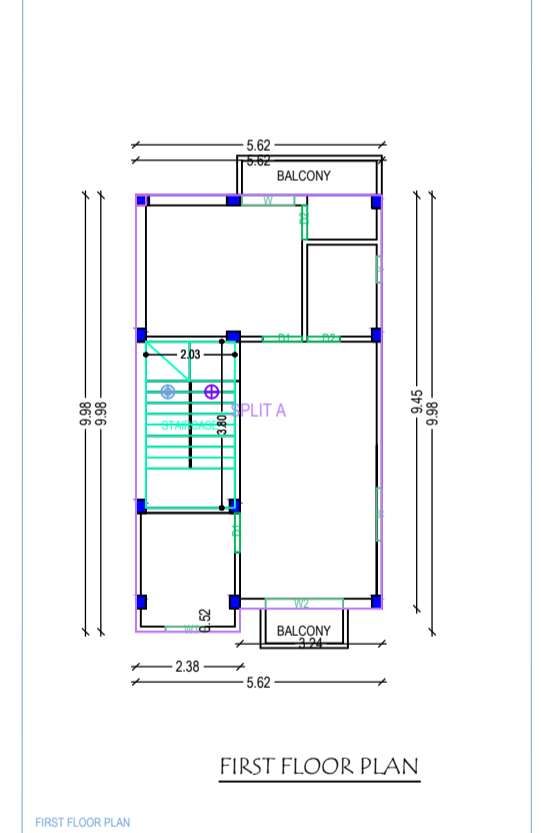
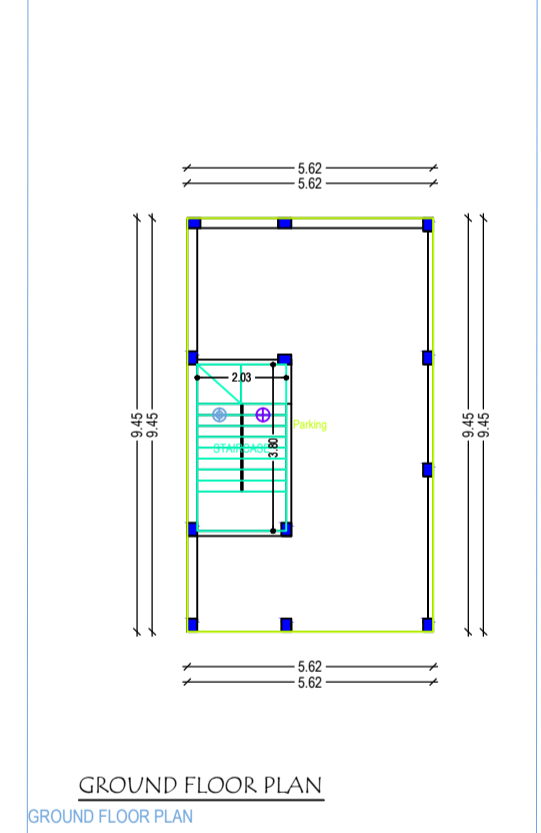
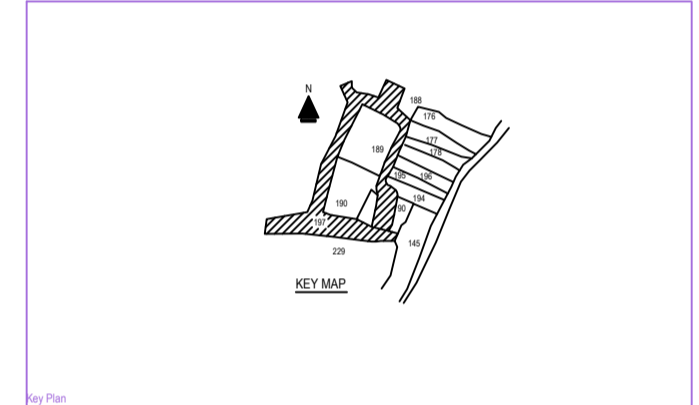
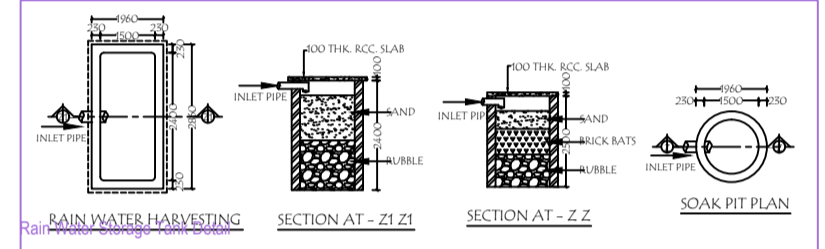
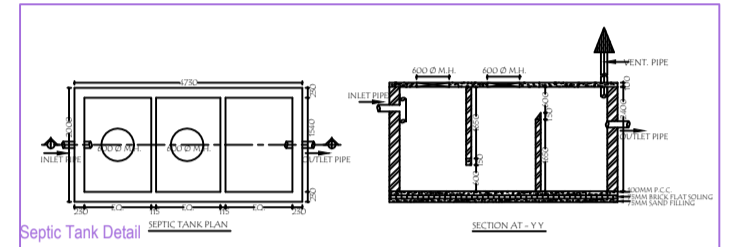
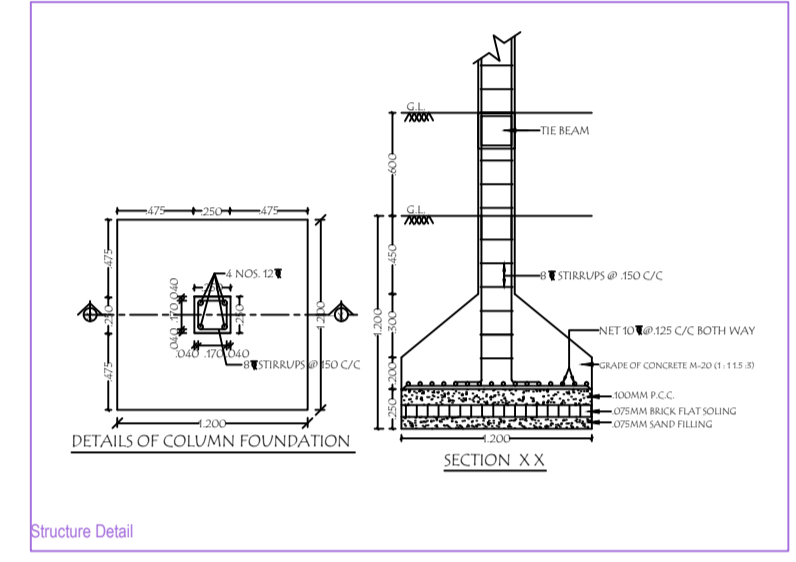
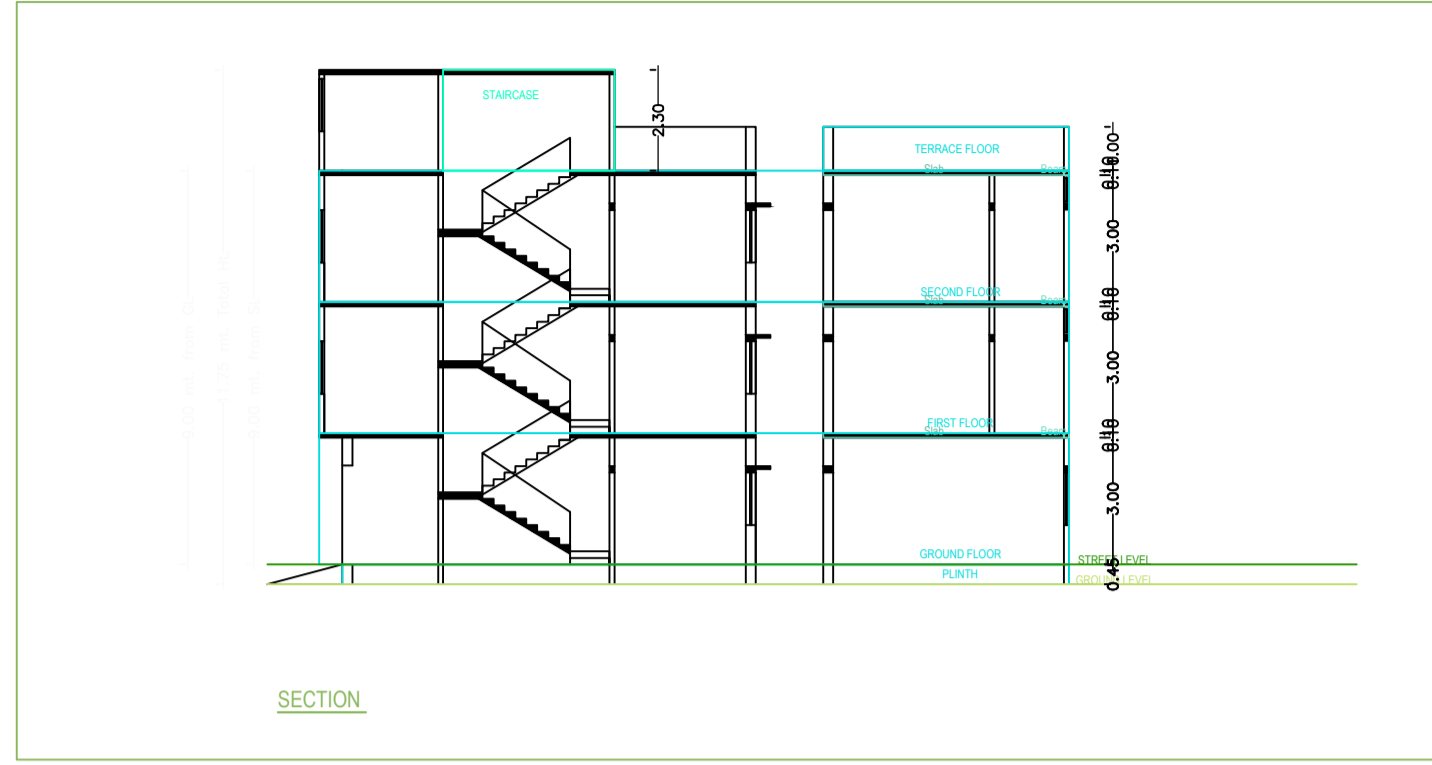
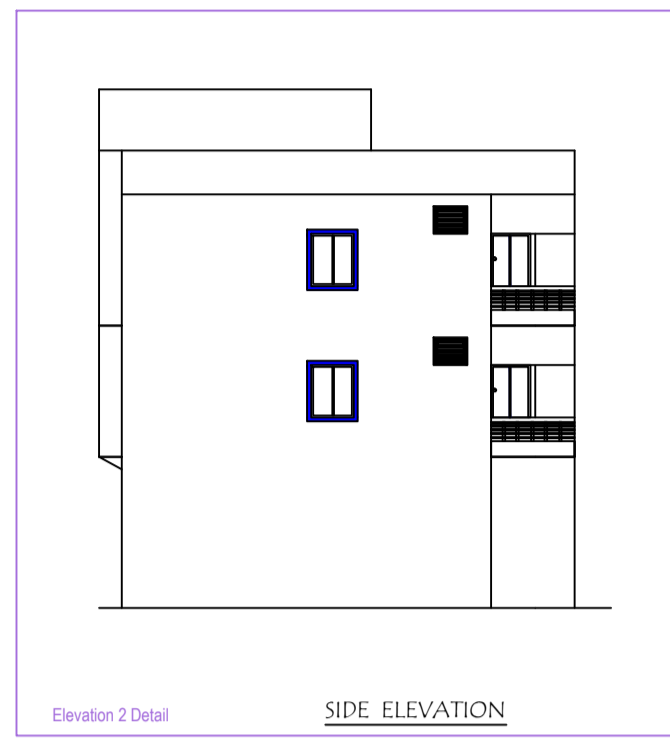
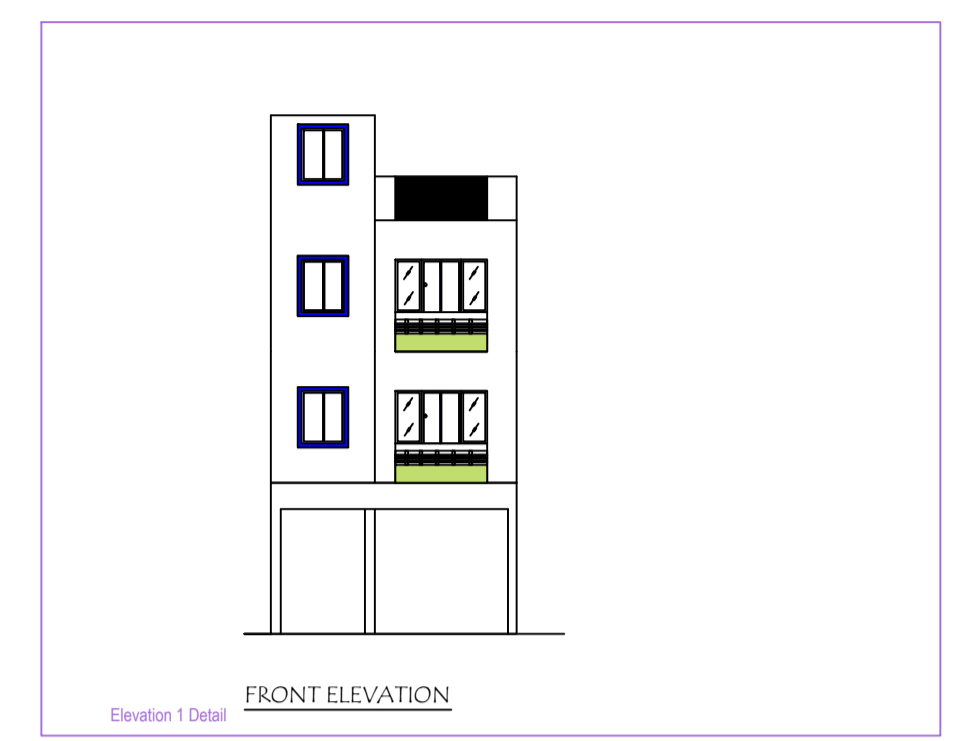

Building A (ANITA AND SATYENDRA)						
Floor Name	Total Built Up Area (Sq.Mt.)	Deductions (Area in Sq.Mt.)		Proposed FAR Area (Sq.Mt.)	Add Area in FAR (Sq.Mt.)	Total FAR Area (Sq.Mt.)
		Balcony	Parking	Total	Star	
Ground Floor	53.11	0.00	45.38	0.00	7.73	7.73
First Floor	54.39	0.00	0.00	54.39	0.00	54.39
Second Floor	98.14	2.39	0.00	95.75	0.00	95.75
Terrace	0.00	0.00	0.00	0.00	0.00	0.00
Total	106.61	2.39	45.38	111.11	7.73	118.84
Total Number of Same Buildings	1					
Total	106.61	2.39	45.38	111.11	7.73	118.84

SCHEDULE OF JOINERY				
BUILDING NAME	NAME	LENGTH	HEIGHT	NO.
A (ANITA AND SATYENDRA)	O2	0.75	2.10	03
A (ANITA AND SATYENDRA)	O2	0.79	2.10	02
A (ANITA AND SATYENDRA)	O1	0.50	2.10	05
A (ANITA AND SATYENDRA)	DW	2.50	2.10	01
Total	-	-	-	11

SCHEDULE OF JOINERY				
BUILDING NAME	NAME	LENGTH	HEIGHT	NO.
A (ANITA AND SATYENDRA)	V	0.60	1.00	02
A (ANITA AND SATYENDRA)	W1	0.90	1.20	02
A (ANITA AND SATYENDRA)	W	1.25	1.20	05
A (ANITA AND SATYENDRA)	W2	1.37	1.20	01
Total	-	-	-	10

Balcony Calculators Table			
FLOOR	SIZE	AREA	TOTAL AREA
GROUND FLOOR PLAN	0.90 X 0.90 X 1 X 1	1.80	4.73
Total	0.90 X 0.90 X 1 X 1	2.39	4.73

UtiliBIA Table for Building A (ANITA AND SATYENDRA)						
FLOOR	Name	UtiliBIA Type	UtiliBIA Area	Carpet Area	No. of Rooms	No. of Tenement
FIRST FLOOR	gpl/F A	FLAT	111.10	111.00	5	1
Total	-	-	111.10	111.00	11	1