

Project Title - SMT SWET NISHA SINGH W/O:- I ATIF SAROJ KUMAR SINGH

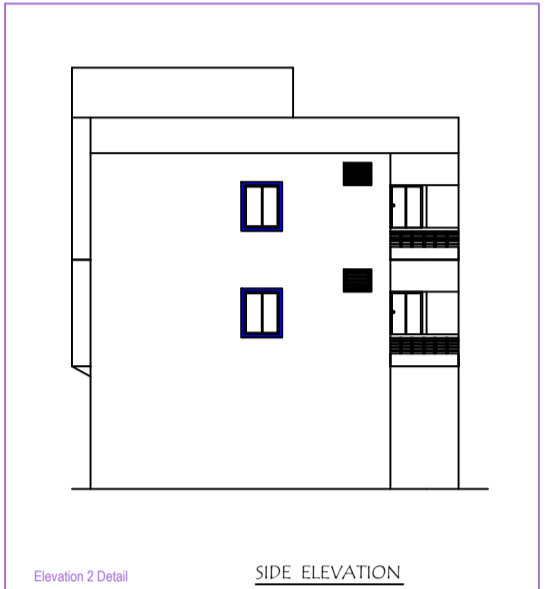

FRONT ELEVATION



SIDE ELEVATION

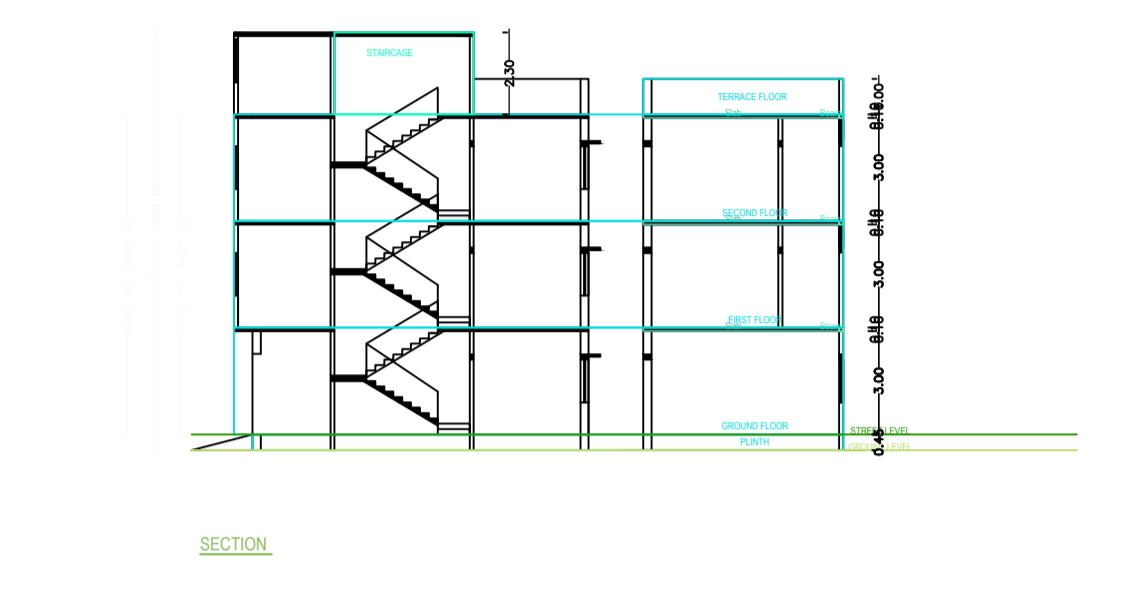

SECTION

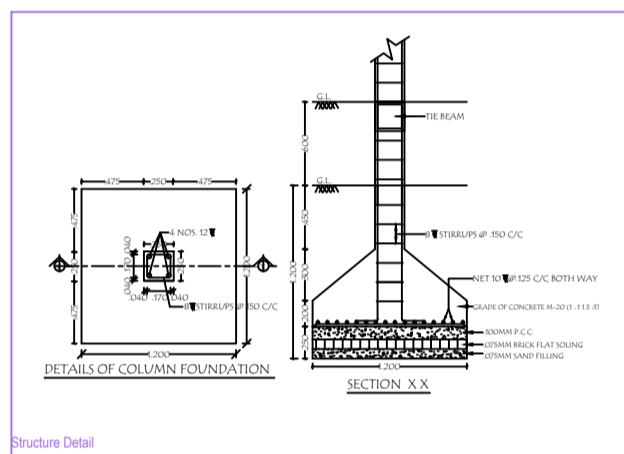

Structure Detail

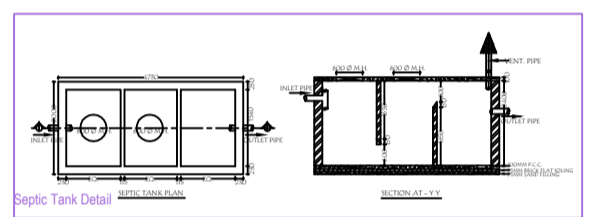

Door Detail

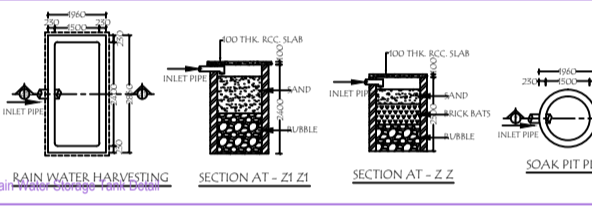

Rain Water Harvesting

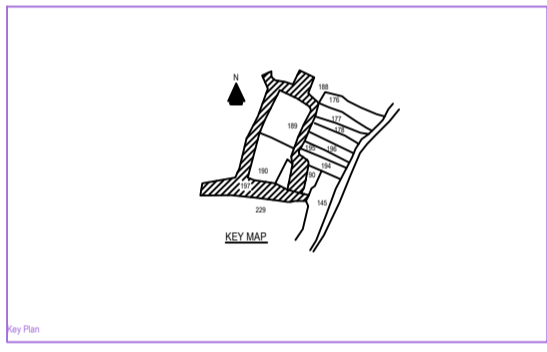

Stair

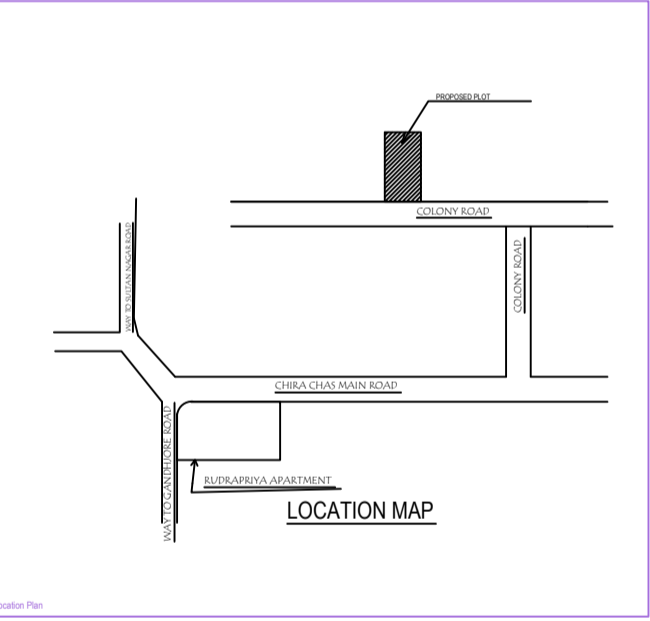

LOCATION MAP

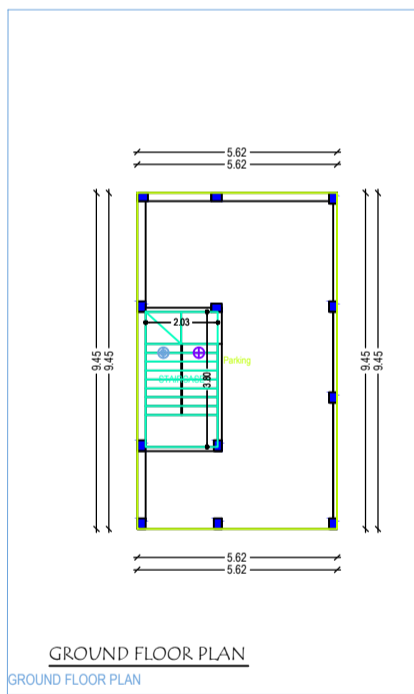

GROUND FLOOR PLAN

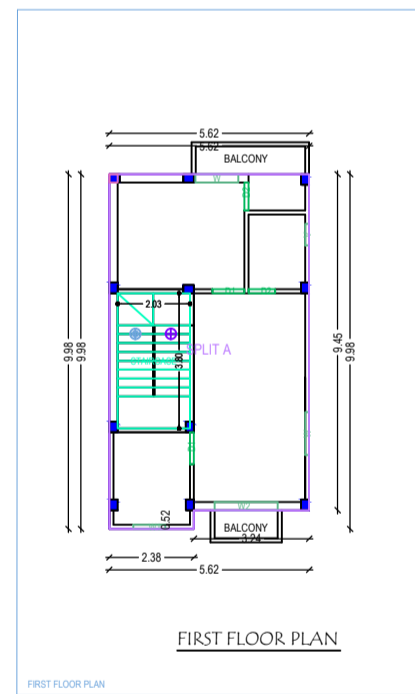

FIRST FLOOR PLAN

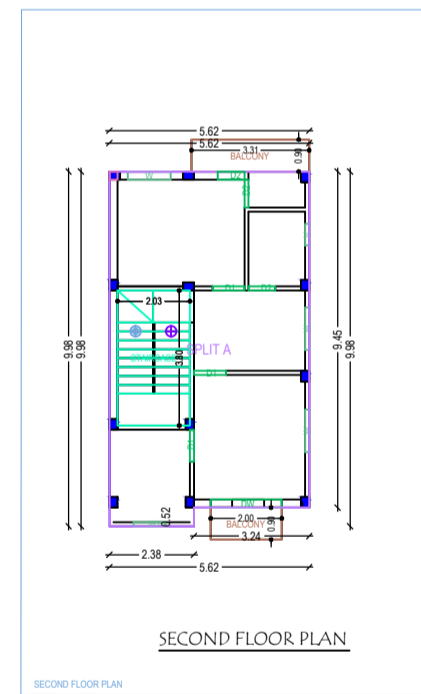

SECOND FLOOR PLAN

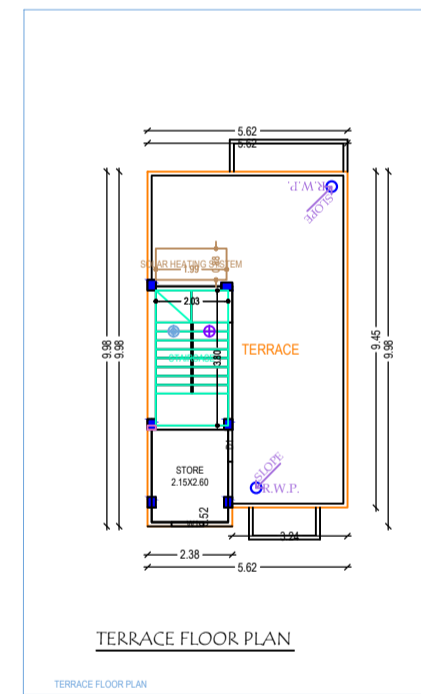

TERRACE FLOOR PLAN

PROJECT DETAILS	
Project No	...
Client Name	...
Project Location	...
Project Date	...
Project Category	...
Project Status	...
Project Manager	...
Project Engineer	...
Project Designer	...
Project Consultant	...
Project Supervisor	...
Project Auditor	...
Project Approver	...
Project Reviewer	...
Project Signatory	...
Project Seal	...

COLOR INDEX	
Blue	...
Green	...
Red	...
Yellow	...
Black	...

PARKING CALCULATION	
Vehicle Type	...
Vehicle Size	...
Vehicle Area	...
Vehicle Spacing	...
Vehicle Density	...
Vehicle Capacity	...

MATERIAL SCHEDULE	
Material Name	...
Material Qty	...
Material Unit	...
Material Price	...
Material Total	...

ITEMS SCHEDULE	
Item Name	...
Item Qty	...
Item Unit	...
Item Price	...
Item Total	...

CONCRETE SCHEDULE	
Concrete Type	...
Concrete Qty	...
Concrete Unit	...
Concrete Price	...
Concrete Total	...

A (SWET NISHA SINGH)

Floor Name	Total Built Up Area (Sq.Mt)	Net Area (Sq.Mt)	Useful Area (Sq.Mt)	Carpet Area (Sq.Mt)	Total Floor Area (Sq.Mt)	Total Volume (Cu.Mt)
GROUND FLOOR	32.38	23.38	23.38	23.38	32.38	118.34
FIRST FLOOR	32.38	23.38	23.38	23.38	32.38	118.34
SECOND FLOOR	32.38	23.38	23.38	23.38	32.38	118.34
TERRACE	32.38	23.38	23.38	23.38	32.38	118.34
STAIR	32.38	23.38	23.38	23.38	32.38	118.34
WC	32.38	23.38	23.38	23.38	32.38	118.34
Year	2020	2020	2020	2020	2020	2020

Material Name	Qty	Unit	Price	Total
WOOD	100	M ²	1000	100000
GLASS	50	M ²	2000	100000
IRON	100	KG	1000	100000
...

Material Name	Qty	Unit	Price	Total
WOOD	100	M ²	1000	100000
GLASS	50	M ²	2000	100000
IRON	100	KG	1000	100000
...

Room	Area (Sq.Mt)	Volume (Cu.Mt)	Weight (Kg)
GROUND FLOOR	32.38	118.34	...
FIRST FLOOR	32.38	118.34	...
SECOND FLOOR	32.38	118.34	...
TERRACE	32.38	118.34	...
STAIR	32.38	118.34	...
WC	32.38	118.34	...

Floor	Room Name	Area (Sq.Mt)	Volume (Cu.Mt)	Weight (Kg)	No. of Batteries
FIRST FLOOR	JPCL A	11.12	39.82	...	1
FIRST FLOOR	JPCL B	11.12	39.82	...	1
FIRST FLOOR	JPCL C	11.12	39.82	...	1
FIRST FLOOR	JPCL D	11.12	39.82	...	1

