

Project Title : SUDHANSHU KUMAR

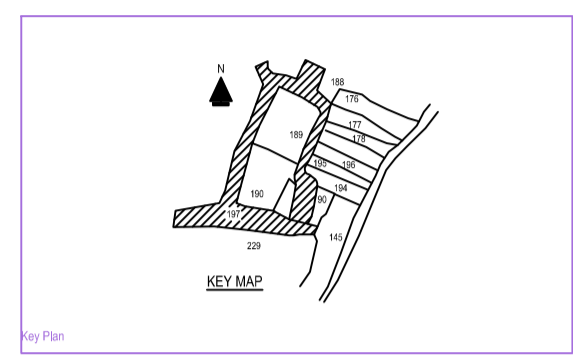

**BRIEF SPECIFICATION**

STEEL = Fe-500 Grade TMT Steel Shall be used.  
 FOUNDATION = CEMENT CONCRETE(1:1.5:3)M20 Grade.  
 SUPERSTRUCTURE = BRICK WORK IN CM(1:6)  
 FLOORING = 25 MM I.P.S./MARBLE/MOSAIC OVER 3" THICK P.C.C.  
 D.P.C. = 25 MM TH. D.P.C. IN CEMENT CONCRETE(1:1.5:3)  
 PLINTH = 0.15 M TH. R.C.C. BAND ALL ROUND IN M20 CONCRETE  
 LINTELS = 0.15 M TH. R.C.C. LINTEL IN M20 GRADE CONCRETE  
 WOOD WORK = ALL WOOD WORK IN HARD WOOD.  
 PLASTERING = 12mm TH. CEMENT PLASTER BOTH SIDE IN CM (1:6)  
 FINISHING = FIRST CLASS APPROVED QUALITY.  
 ANTITERMITE = ANTI TERMITE TREATMENT IN FLOOR SHALL BE DONE.  
 WATER PROOFING = ROOF AND WALL SHALL BE OF WATER RESISTANT.  
 DRAINAGE = ADEQUATE DRAINAGE SHALL BE PROVIDED.  
 IS CODES = BUILDING CODE OF INDIA SHALL BE FOLLOWED.  
 CEMENT = 53 GRADE PRODUCED FROM 'A' GRADE PLANT.  
 WALL = OUTER(0.23 THICK) & INNER(0.12 THICK)

**SCHEDULE OF OPENINGS**

D2 =0.75X2.10      D1 =0.90X2.10      D =1.00X2.10  
 V =0.60X0.45      W1 =0.90X1.20      W =1.20X1.20

**SCHEDULE OF AREA**

**TITLE OF DRAWING**

SIGNATURE OF ENGINEER

SIGNATURE OF OWNER

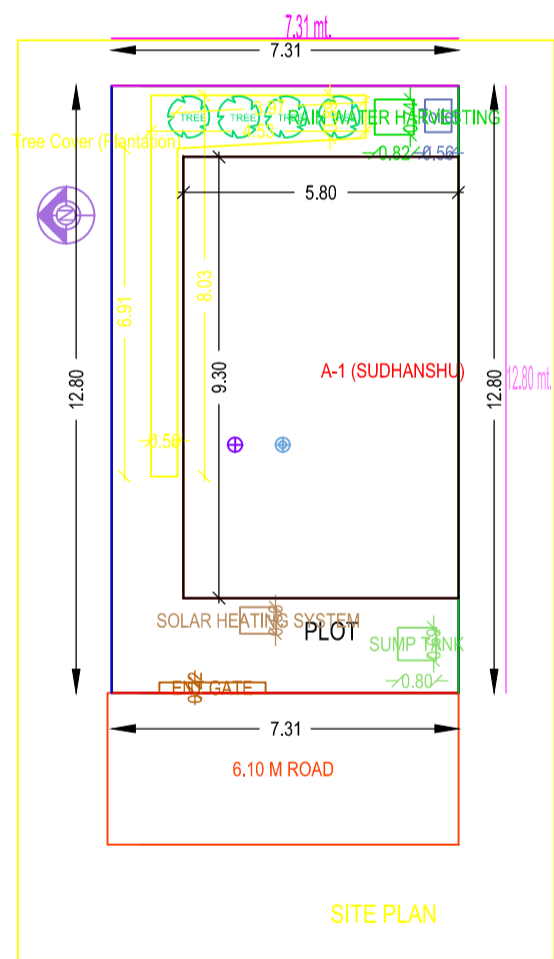
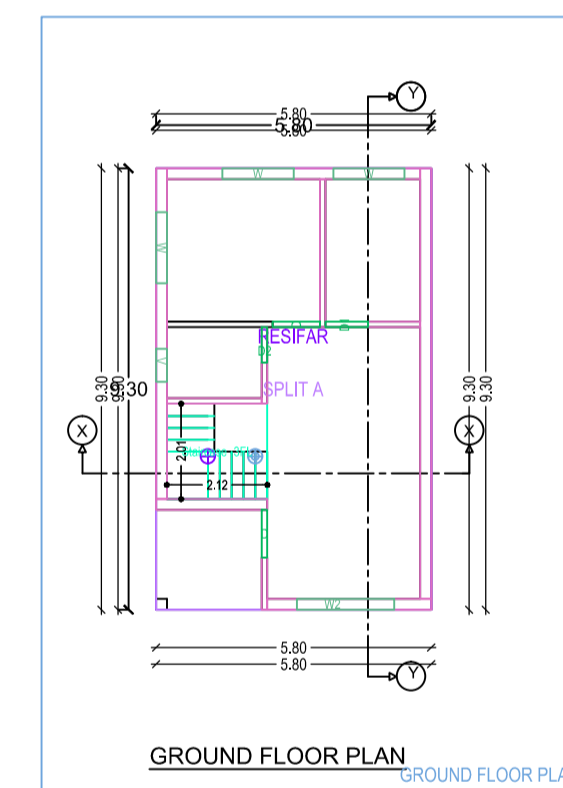
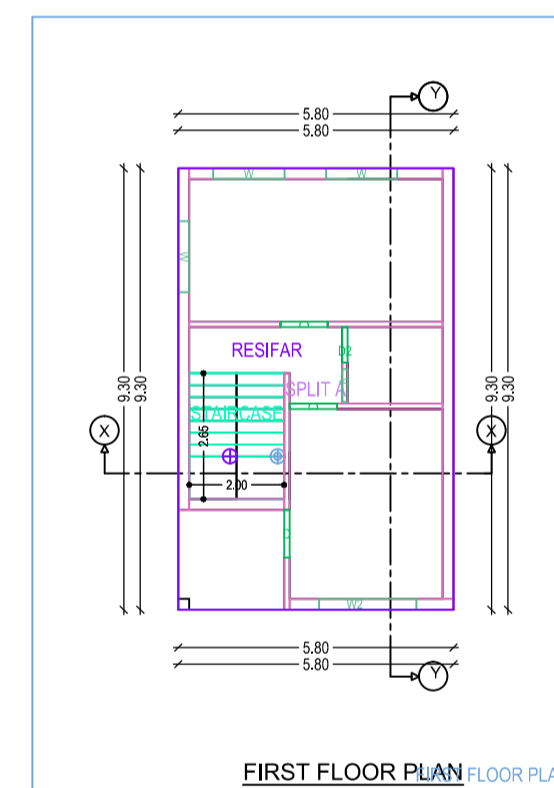
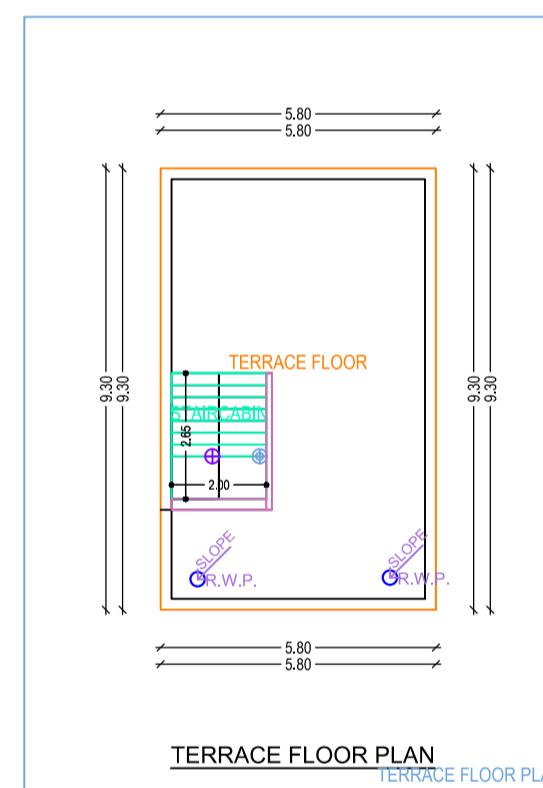
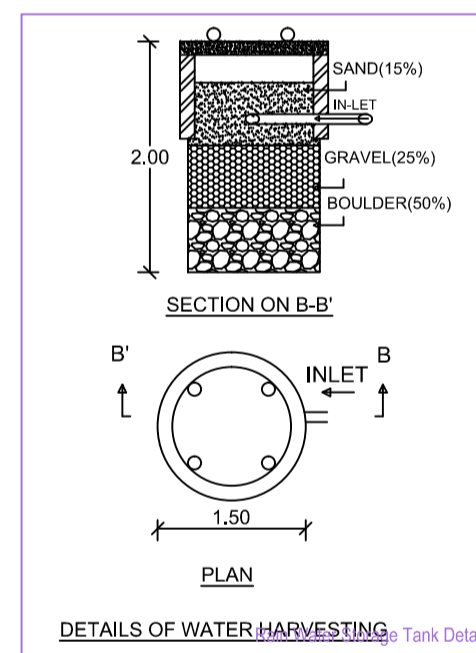
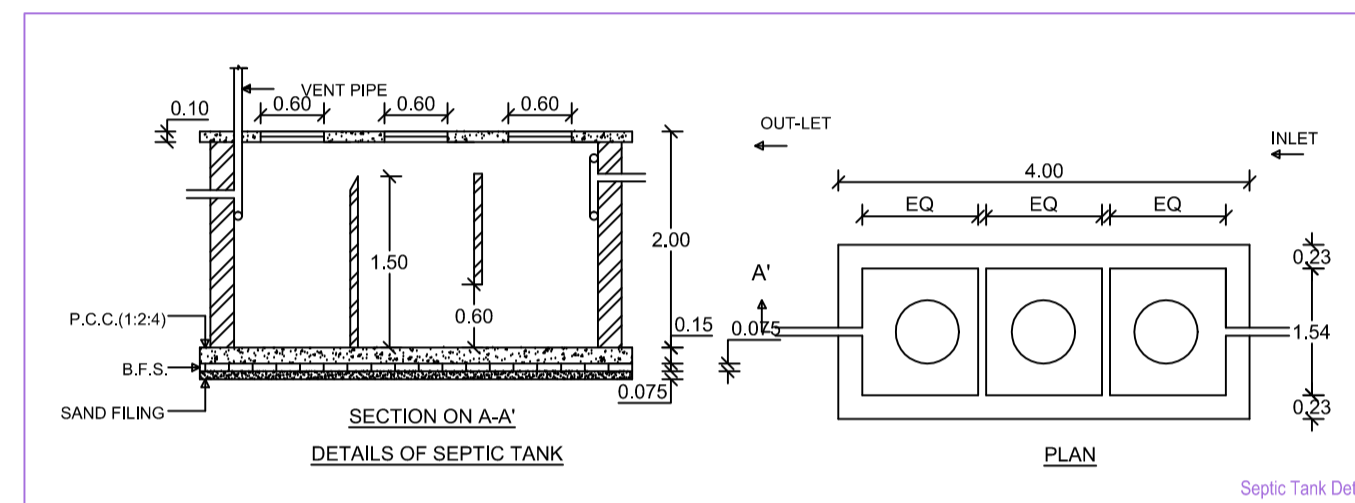
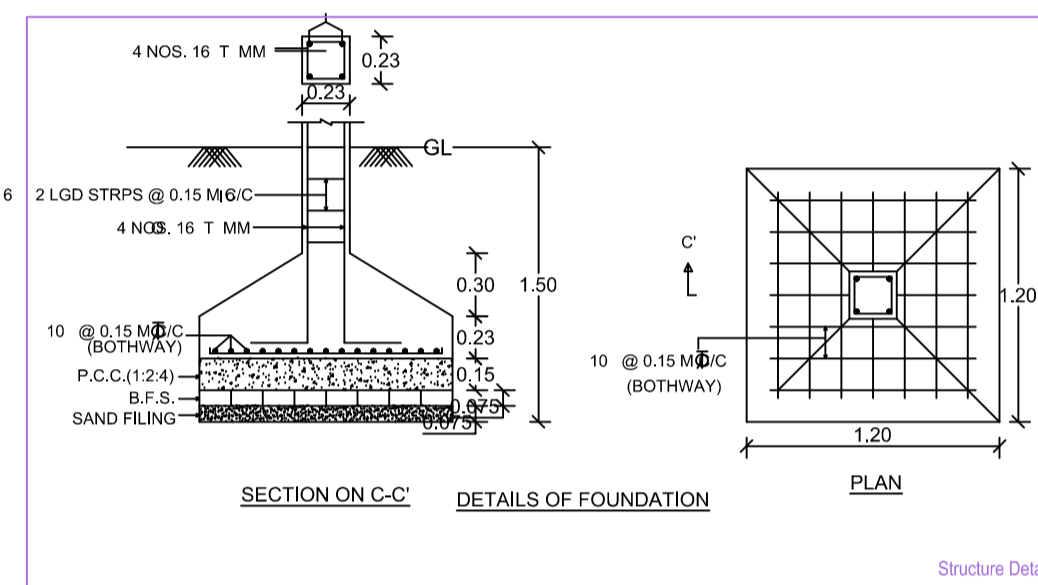
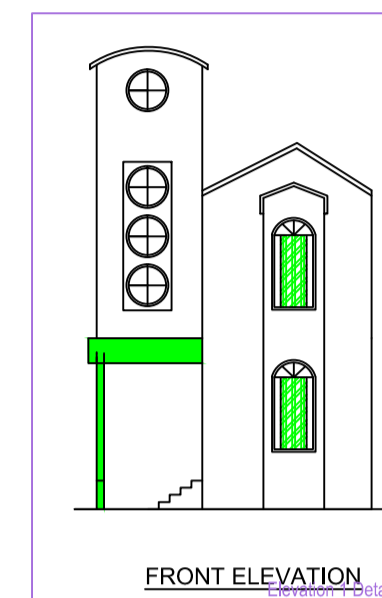
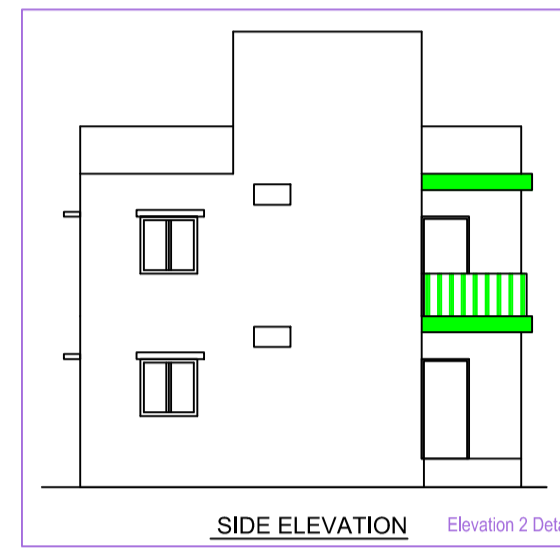
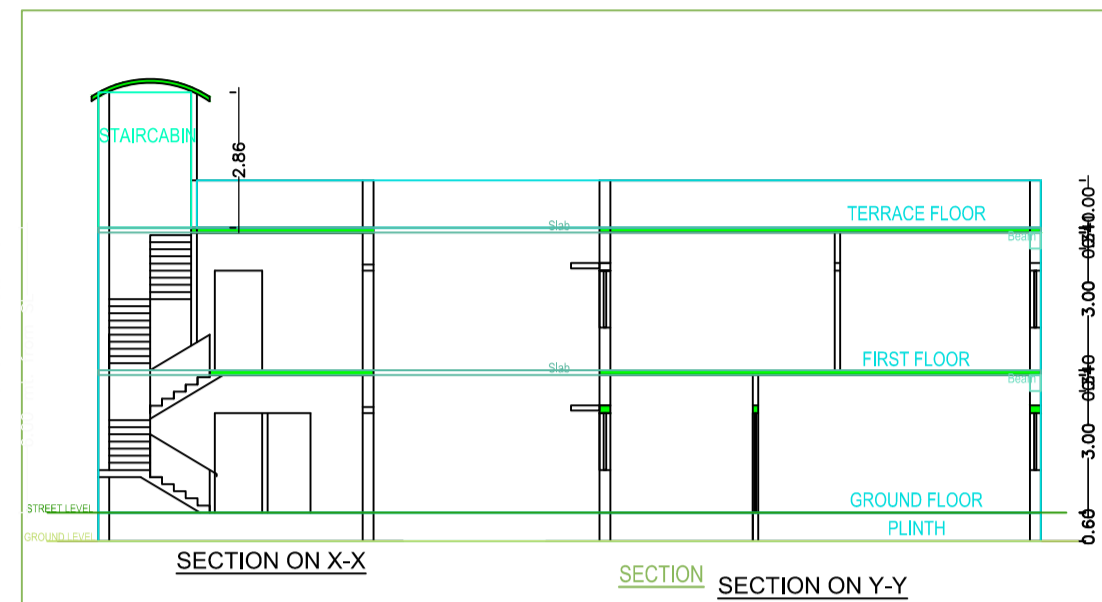

AREA STATEMENT: GHAS MUNICIPAL CORPORATION		VERSION NO. 1.0.20
PROJECT DETAIL:		VERSION DATE: 16/10/2020
Plot No. :-	Plot Use: Residential	
Region :-	Plot Subdiv: Bangalore Dwelling - Non Apartment	
System: BROWARD	Land Use Code: RA	
Application Type: General Proposal	Adjoining Road Width: -	
Project Type: Building Permission	Plot No. :-	
Nature of Development: New	Revenue Survey No./Survey No. :-	
Location: Old Area	Thana No. :-	
Site Location: N/S	Planning No. :-	
Village/Muza Name: -	Khata No. :-	
Ward No. :-	North :-	
Road/Street :-	South :-	
	East :-	
	West :-	

AREA DETAILS		sq.MT.
AREA OF PLOT (Minimum)	(A)	93.57
Net Plot Area (Less Plot Area)	(A-Deductions)	93.57
- Deduction from Gross Plot area		
- Deductions for Balance Plot Area (from Gross Plot Area)		
COP Area		8.50
Total		8.50
Balance Plot Area (Net Plot Area - Recreational/amenity space)	(A-Deductions)	85.06
Plot Area for Coverage (Net Plot Area)	(A-Deductions)	93.57
Plot Area for FSI (Net Plot Area - Recreational/amenity space)	(A-Deductions)	93.57
Accey/area Area		6.38
COVERAGE CHECK		
Proposed Coverage Area (87.85 %)		83.94
Total Coverage Area (87.85 %)		83.94
FAR CHECK		
Proposed Area of FAR		107.88
Total Area of FAR		107.88
BUILT UP AREA CHECK		
Total Proposed Built Up Area		107.88
PERMIT FUND: SUPERVISOR (Regd)	OWNER	

COLOR INDEX	
Plot Boundary	Red
Setback Road	Green
Proposed Work (Coverage Area)	Blue
Existing (To be retained)	Yellow
Existing (To be demolished)	Black

MARGIN DETAIL:					
Building / Plot	Road Name	Front Margin	Rear Margin	Side Margin	Side Margin
A1	6.10 M ROAD (SUDHANSHU)	2.00	1.50	1.51	0.00

FAR & Terment Details (Table 4c-1)					
Building	No. of Same Bldg	Total Built Up Area (Sq.M)	Proposed FAR Area (Sq.M)	Total FAR Area (Sq.M)	Terr (%)
A (SUDHANSHU)	1	107.88	107.88	107.88	01
Grand Total:	1	107.88	107.88	107.88	01

Building 'A' (SUDHANSHU)				
Floor Name	Total Built Up Area (Sq.M)	Proposed FAR Area (Sq.M)	Total FAR Area (Sq.M)	Terr (%)
Ground Floor	53.94	53.94	53.94	01
First Floor	53.94	53.94	53.94	01
Terrace Floor	0.00	0.00	0.00	00
Total	107.88	107.88	107.88	01
Total Number of Same Buildings	1			
Total	107.88	107.88	107.88	01

SCHEDULE OF JOINERY:				
BUILDING NAME	NAME	LENGTH	HEIGHT	NOS
A (SUDHANSHU)	D1	0.75	2.10	02
A (SUDHANSHU)	D1	0.90	2.10	01
A (SUDHANSHU)	D	1.00	2.10	05
Total	-	-	-	08

SCHEDULE OF JOINERY:				
BUILDING NAME	NAME	LENGTH	HEIGHT	NOS
A (SUDHANSHU)	V	0.60	1.20	02
A (SUDHANSHU)	W1	1.50	1.20	08
A (SUDHANSHU)	W2	2.05	1.20	02
Total	-	-	-	10

UrbBUA Table for Building 'A' (SUDHANSHU)						
FLOOR	Name	URBUA Type	URBUA Area	Carpet Area	No. of Rooms	No. of Tenement
GROUND FLOOR PLAN	SPLIT A	FLAT	107.88	93.07	5	1
Total	-	-	107.88	93.07	5	1