

DETAILS OF SEPTIC TANK

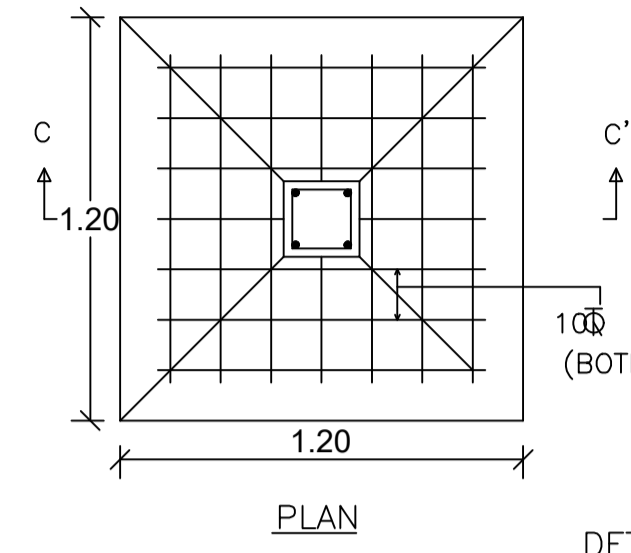

DETAILS OF FOUNDATION

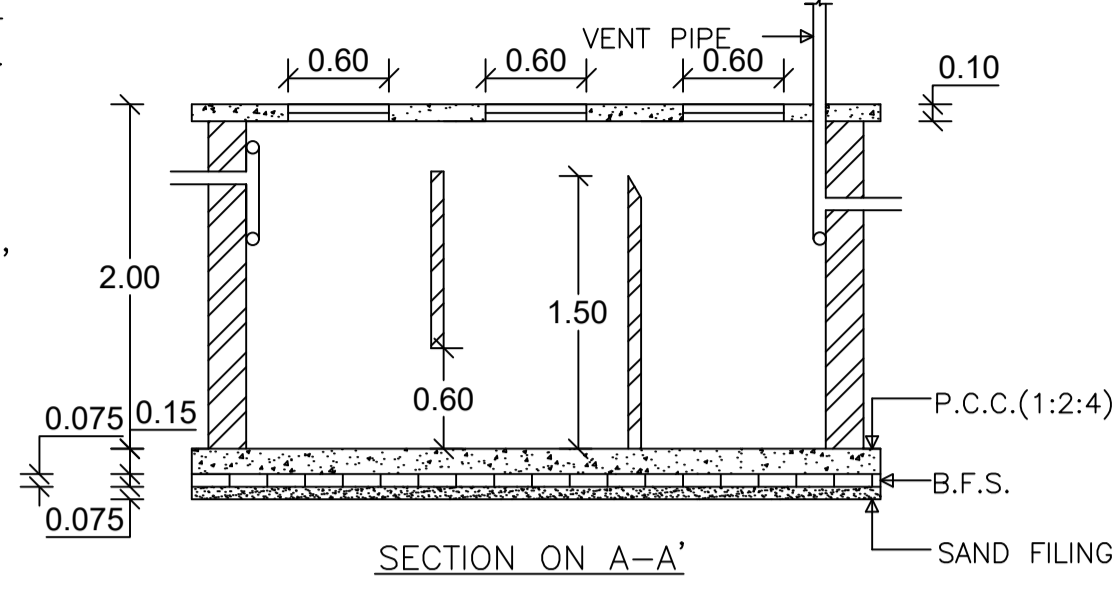
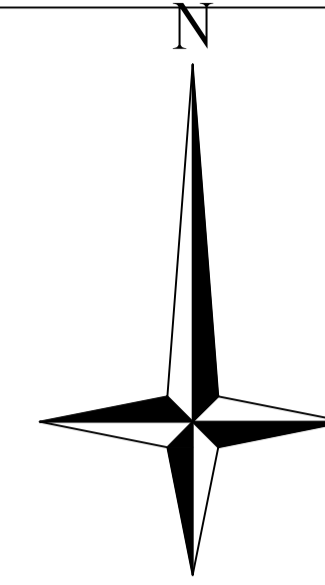
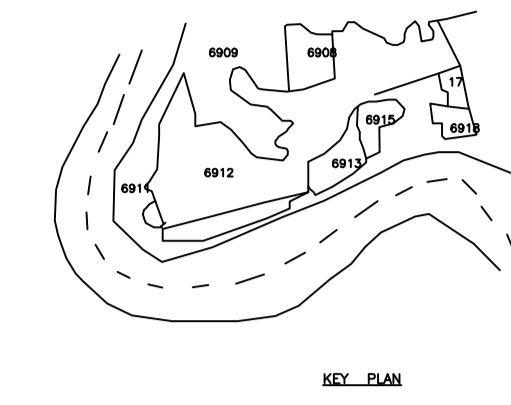
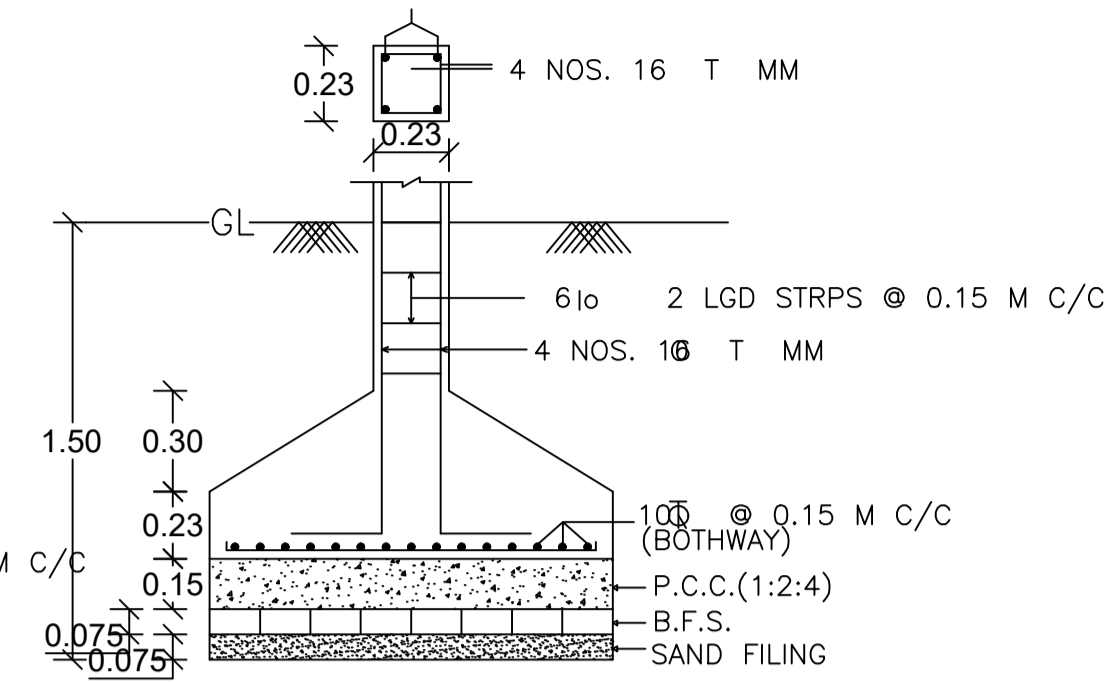

Proposal Basic Information	
Proposal File No.	CMC/BP/0201/W22/2021
Owner Name	PRIYANKA KUMARI BARNWAL
Khata No	405
Plot No	6909
Village Name	Chas
Use	Residential
SubUse	Bungalow/ Dwelling / Non Apartment

AREA STATEMENT CHAS MUNICIPAL CORPORATION		VERSION NO. 1.0.60
PROJECT DETAIL:		VERSION DATE: 16/10/2020
Region: JHARKHAND URBAN LOCAL BODIES	Plot Use: Residential	SQ. MT.
District: BOKARO	Plot SubUse: Bungalow/ Dwelling / Non Apartment	
Authority: CHAS MUNICIPAL CORPORATION	PlotNearbyReligiousStructure: NA	
Inward No: CMC/BP/0201/W22/2021	Plot/SubPlot No: 6909	
Application Type: General Proposal	North: CTS No. - KAMTA SINGH	
Project Type: Building Permission	South: Road Width - ROAD	
Nature of Development: New	East: CTS No. - CHANCHALA DEVI AND RAKHI PRASAD	
Location of Development Area: Old Area	West: Road Width - ROAD	
AREA DETAILS:		
AREA OF PLOT (Minimum)	(A)	242.38
NET AREA OF PLOT(Gross Plot Area - Deduction from Gross Plot area)	(A-Deductions)	242.38
Deduction for Balance Plot Area(from Gross Plot Area)		
Common Plot		18.20
Total		18.20
BALANCE AREA OF PLOT(Net Plot Area - Recreational/Amenity space)	(A-Deductions)	224.18
PLOT AREA FOR COVERAGE(Net Plot Area)	(A-Deductions)	242.38
Plot Area for FAR (Net Plot Area + Road Widening Area)	(A-Deductions)	242.38
COVERAGE CHECK		
Permissible Coverage area (60.00 %)		145.43
Proposed Coverage Area (59.97 %)		145.36
Total Prop. Coverage Area (59.97 %)		145.36
Balance coverage area (0.03 %)		0.07
FAR CHECK		
Perm. FAR Area (1.50)		363.57
Total Perm. FAR area		363.57
Residential FAR		350.81
Proposed FAR Area		350.81
Total Proposed FAR Area		350.81
Consumed FAR (Factor)		1.45
Balance FAR Area		12.76
BUILT UP AREA CHECK		
Total Proposed BuiltUp Area		379.98
ARCHITECT (Regd)		DINABANDHU RAJAK
ENGINEER (Regd)		
SUPERVISOR (Regd)		
OWNER (Regd)		PRIYANKA KUMARI BARNWAL
DEVELOPMENT AUTHORITY		LOCAL BODY

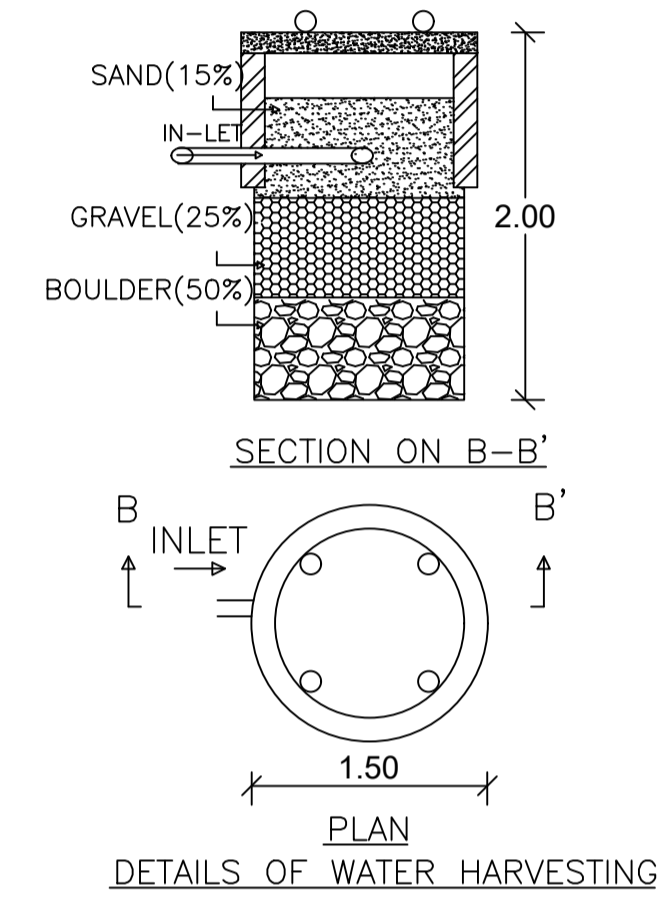
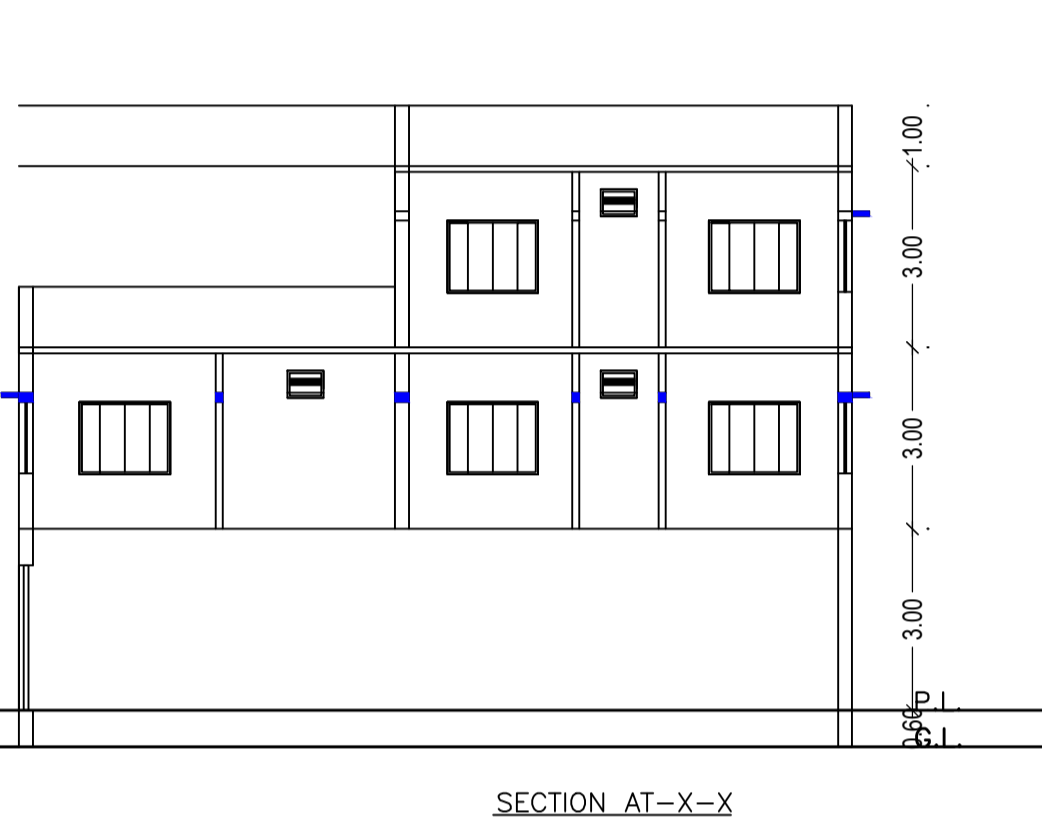
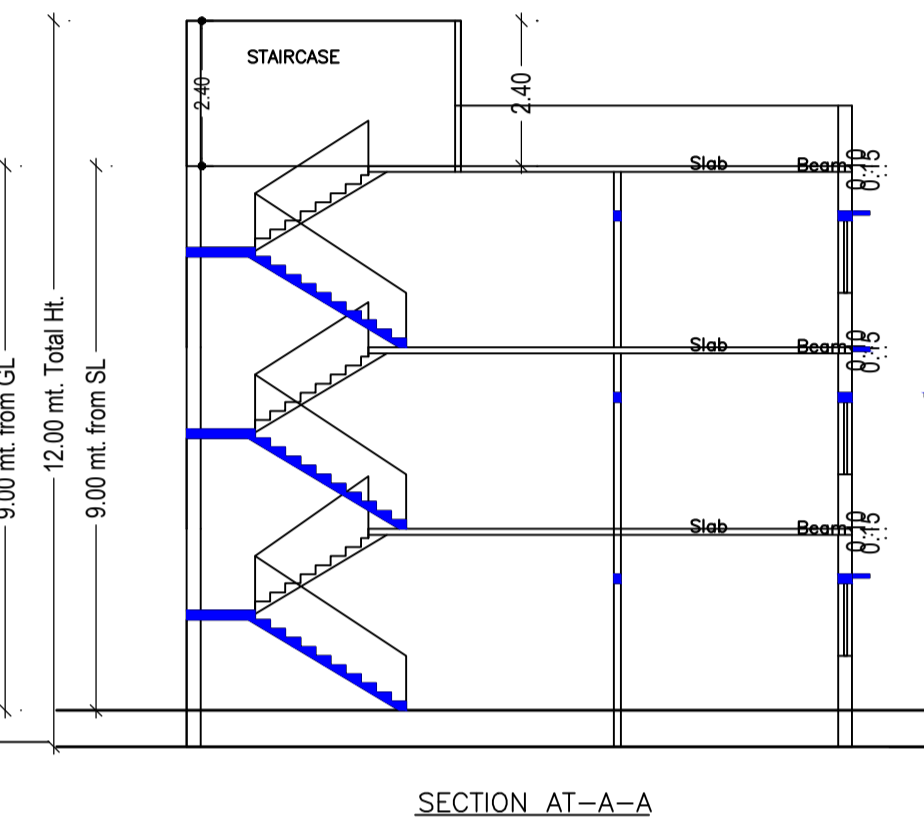
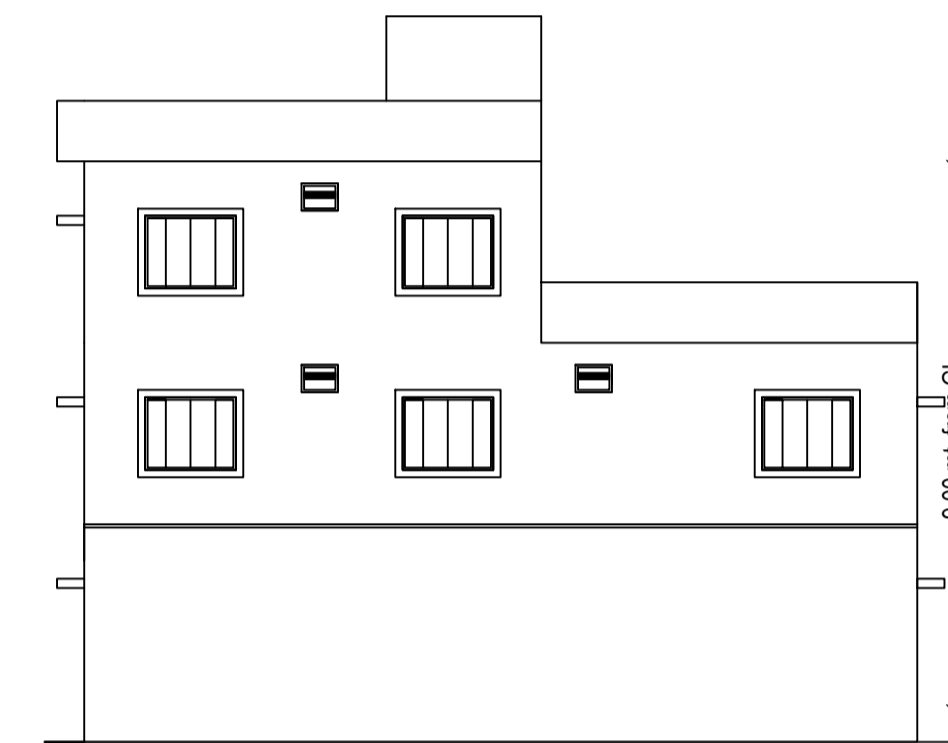
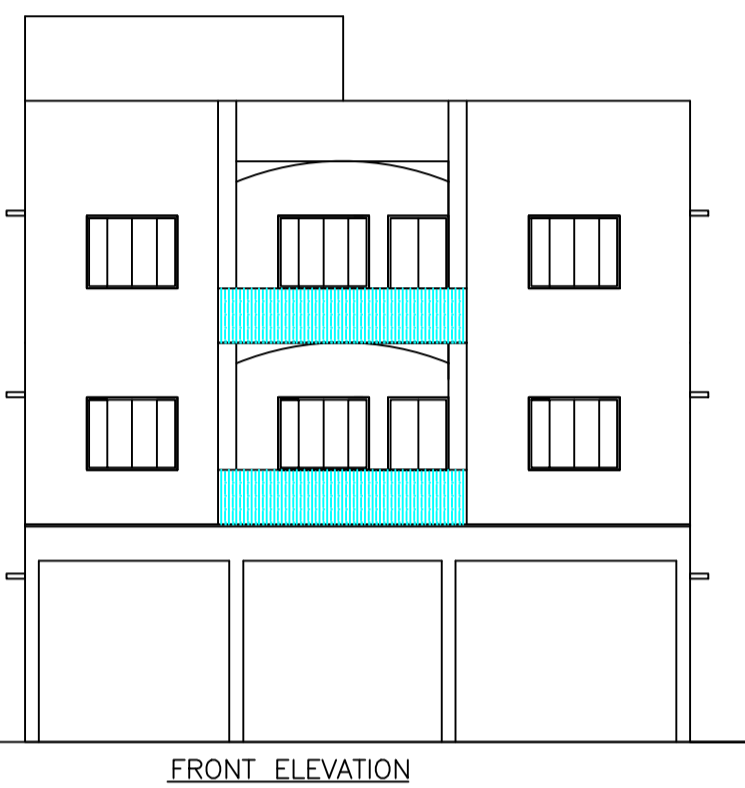

DETAILS OF WATER HARVESTING

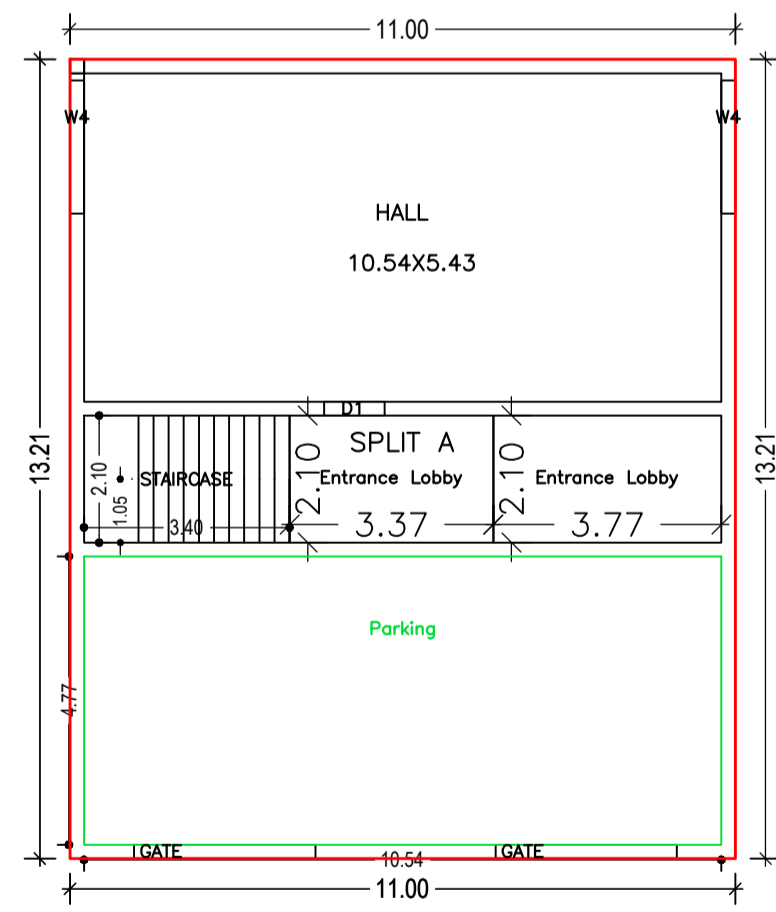

GROUND FLOOR PLAN (Proposed) (SCALE 1:100)

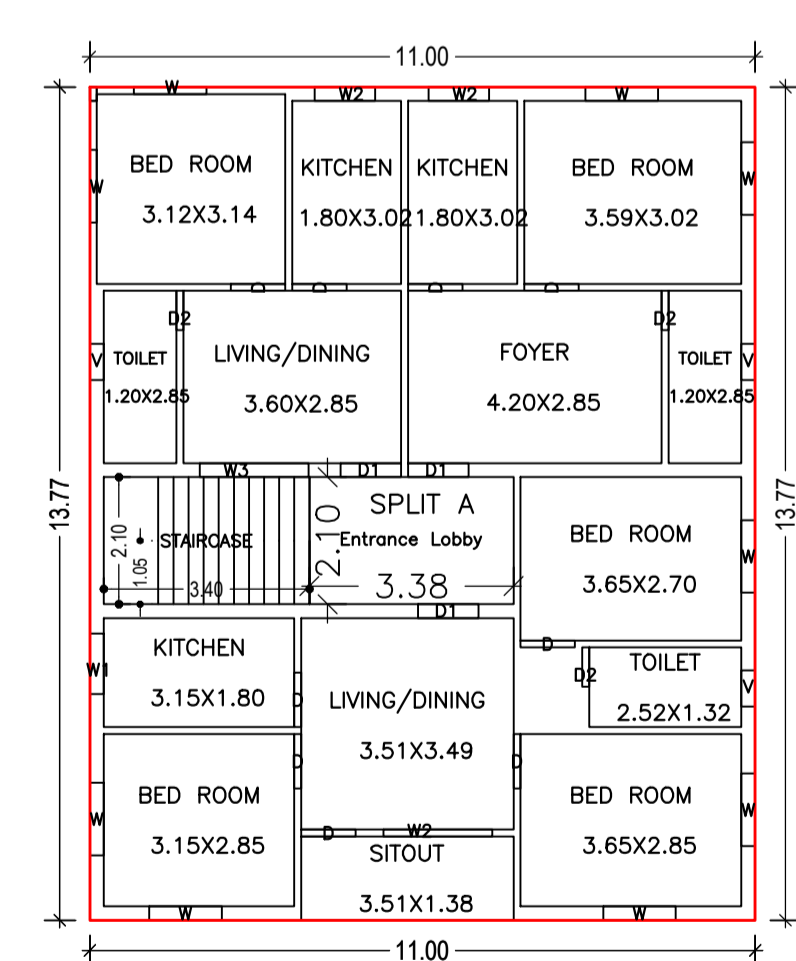

FIRST FLOOR PLAN (Proposed) (SCALE 1:100)

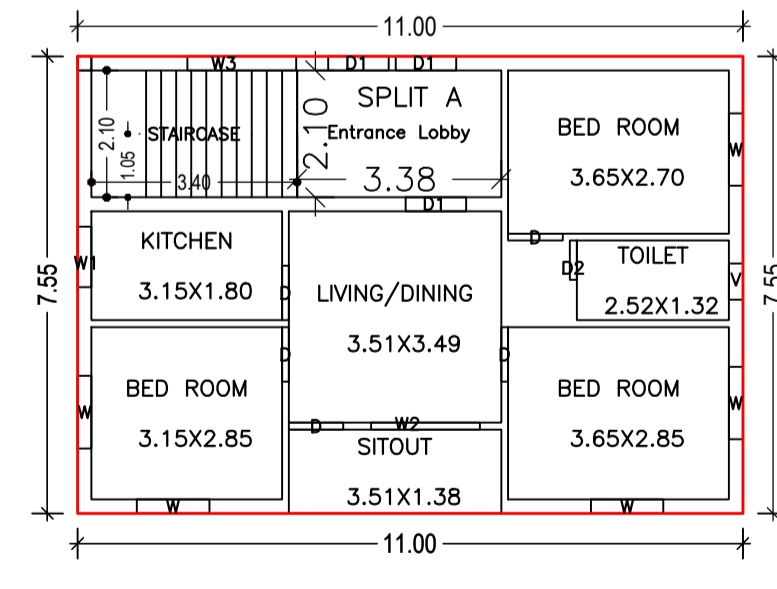

SECOND FLOOR PLAN (Proposed) (SCALE 1:100)

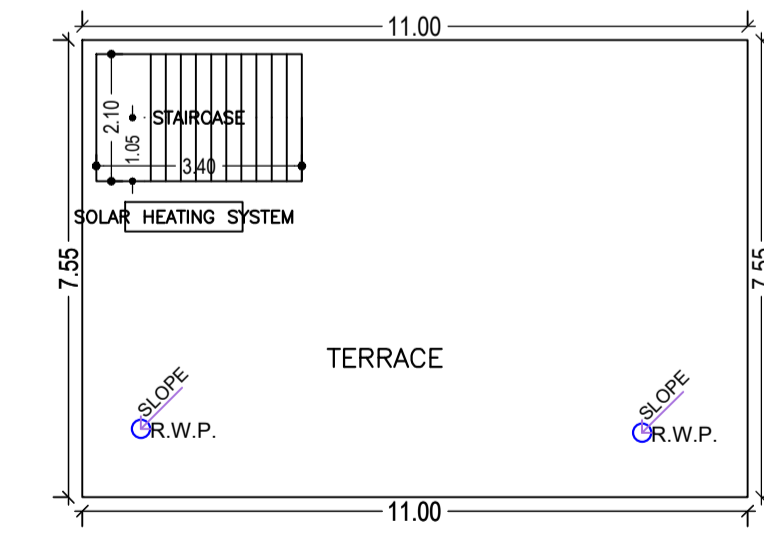

TERRACE FLOOR PLAN (SCALE 1:100)

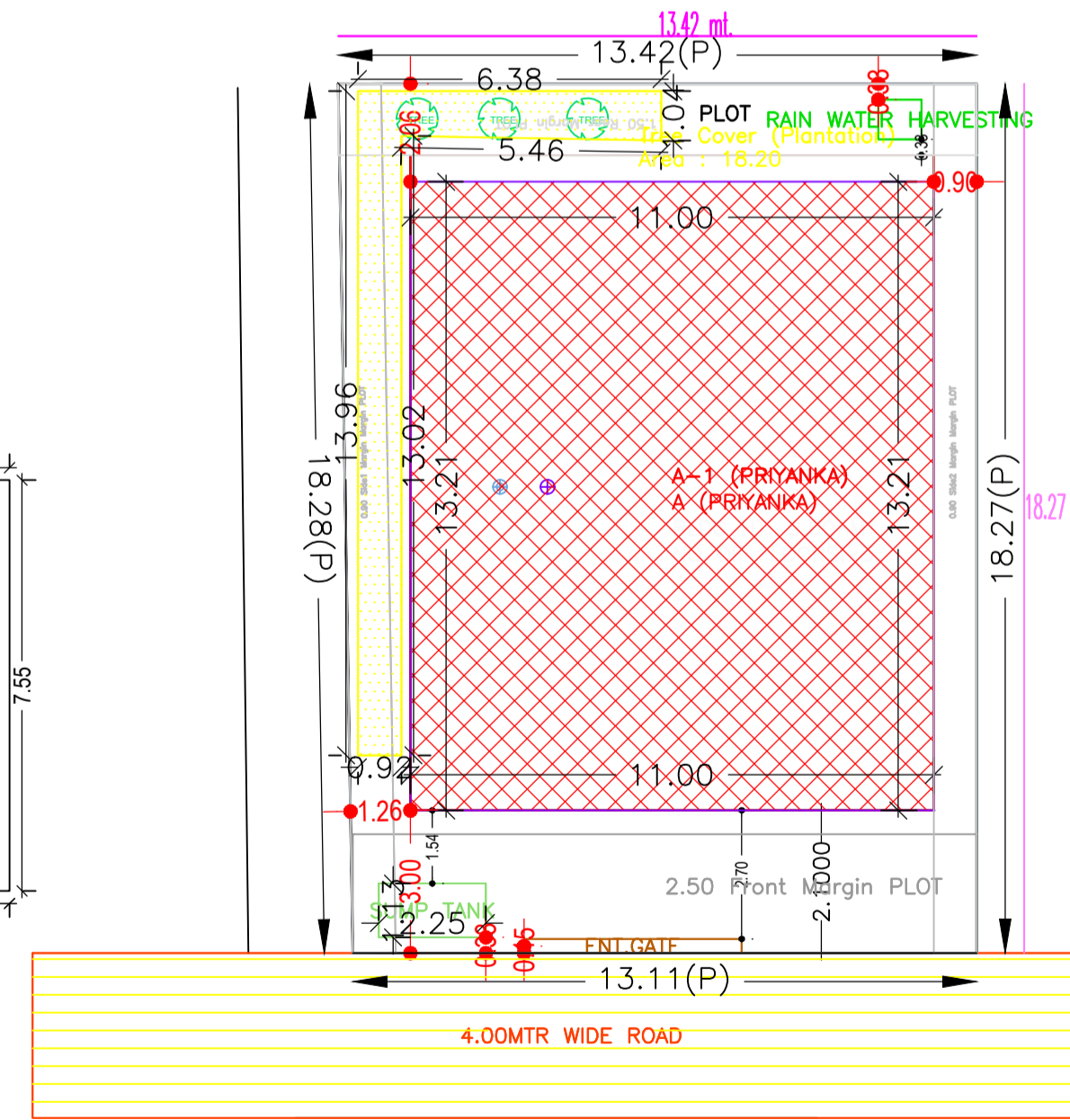

SITE PLAN

FAR & Tenement Details (Table 4c-1)

Building	No. of Same Bldg	Total Built Up Area (Sq.mt.)	Deductions (Area in Sq.mt.)		Proposed FAR Area (Sq.mt.)	Total FAR Area (Sq.mt.)	Total Consumed Additional FAR Area (Sq.mt.)	Trmt (No.)
			Accessory Use	Resi.				
A (PRIYANKA)	1	379.98	29.17	350.81	350.81	350.81	350.81	01
Grand Total :	1	379.98	29.17	350.81	350.81	350.81	350.81	01

Building :A (PRIYANKA)

Floor Name	Total Built Up Area (Sq.mt.)	Deductions (Area in Sq.mt.)	Proposed FAR Area (Sq.mt.)	Total FAR Area (Sq.mt.)	Total Consumed Additional FAR Area (Sq.mt.)	Trmt (No.)
Ground Floor	145.35	14.99	130.36	130.36	130.36	01
First Floor	151.52	7.09	144.43	144.43	144.43	00
Second Floor	83.11	7.09	76.02	76.02	76.02	00
Terrace Floor	0.00	0.00	0.00	0.00	0.00	00
Total :	379.98	29.17	350.81	350.81	350.81	01
Total Number of Same Buildings	1					
Total :	379.98	29.17	350.81	350.81	350.81	01

SCHEDULE OF DOOR:

BUILDING NAME	NAME	LENGTH	HEIGHT	NOS
A (PRIYANKA)	D2	0.65	2.10	04
A (PRIYANKA)	D1	0.90	2.10	14
A (PRIYANKA)	D1	1.00	2.10	06

SCHEDULE OF WINDOW/VENTILATION:

BUILDING NAME	NAME	LENGTH	HEIGHT	NOS
A (PRIYANKA)	V	0.60	1.20	04
A (PRIYANKA)	W2	1.00	1.20	02
A (PRIYANKA)	W1	1.00	1.20	02
A (PRIYANKA)	W	1.20	1.20	14
A (PRIYANKA)	W	1.20	1.20	02
A (PRIYANKA)	W2	1.80	1.20	02
A (PRIYANKA)	W2	1.80	1.20	02
A (PRIYANKA)	W4	2.20	1.20	02

Building USE/SUBUSE Details			
Building Name	Building Use	Building SubUse	Building Structure
A (PRIYANKA)	Residential	Bungalow/ Dwelling / Non Apartment	Non-Highrise

UnitBUA Table for Building :A (PRIYANKA)

FLOOR	Name	UnitBUA Type	UnitBUA Area	Carpet Area	No. of Rooms	No. of Tenement
GROUND FLOOR PLAN	SPLIT A	FLAT	379.98	379.85	1	1
FIRST FLOOR PLAN	SPLIT A	FLAT	0.00	0.00	15	0
SECOND FLOOR PLAN	SPLIT A	FLAT	0.00	0.00	7	0
Total:	-	-	379.98	379.85	23	1

Buildingwise Floor FAR Details

Floor Name	Building Name A (PRIYANKA)		Total	
	Proposed Built Up Area (Sq.mt.)	Proposed FAR Area (Sq.mt.)	Total Proposed Built Up Area (Sq.mt.)	Total FAR Area (Sq.mt.)
Ground Floor	145.35	130.36	145.35	130.36
First Floor	151.52	144.43	151.52	144.43
Second Floor	83.11	76.02	83.11	76.02
Terrace Floor	0.00	0.00	0.00	0.00
Total :	379.98	350.81	379.98	350.81

COLOR INDEX	
PLOT BOUNDARY	Black
ABUTTING ROAD	Red
PROPOSED CONSTRUCTION	Green
COMMON PLOT	Blue
ROAD WIDENING AREA	Yellow
EXISTING (To be retained)	White
EXISTING (To be demolished)	Grey

LTP NAME AND SIGNATURE	STRUCTURAL ENG'S NAME AND SIGNATURE	BUILDER NAME AND SIGNATURE	DIGITAL SIGNATURE
DINABANDHU RAJAK CMC/ENG/0001/2020			