

Proposal Basic Information

Proposal File No.	CMC/BP/0328/W07/2021
Owner Name	RAKESH ROSHAN AND SWETA KUMARI
Khata No	742
Plot No	2835,2836
Village Name	Chas
Use	Residential
SubUse	Bungalow/ Dwelling / Non Apartment

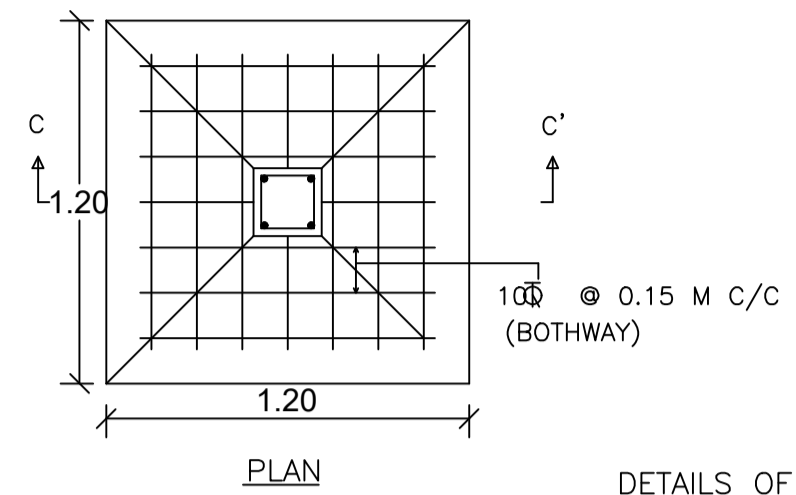

DETAILS OF FOUNDATION

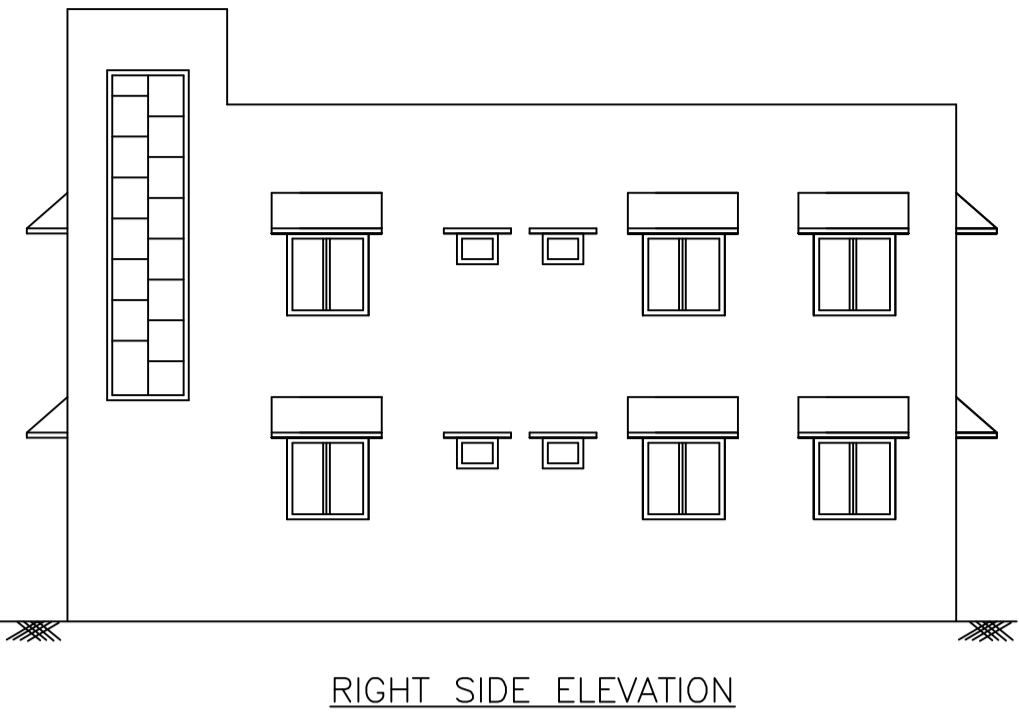
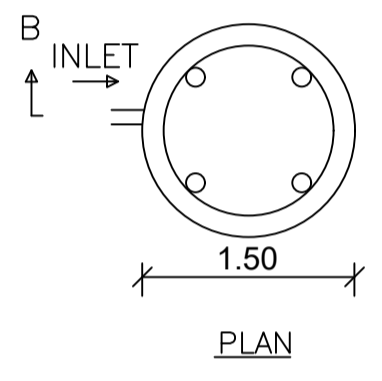
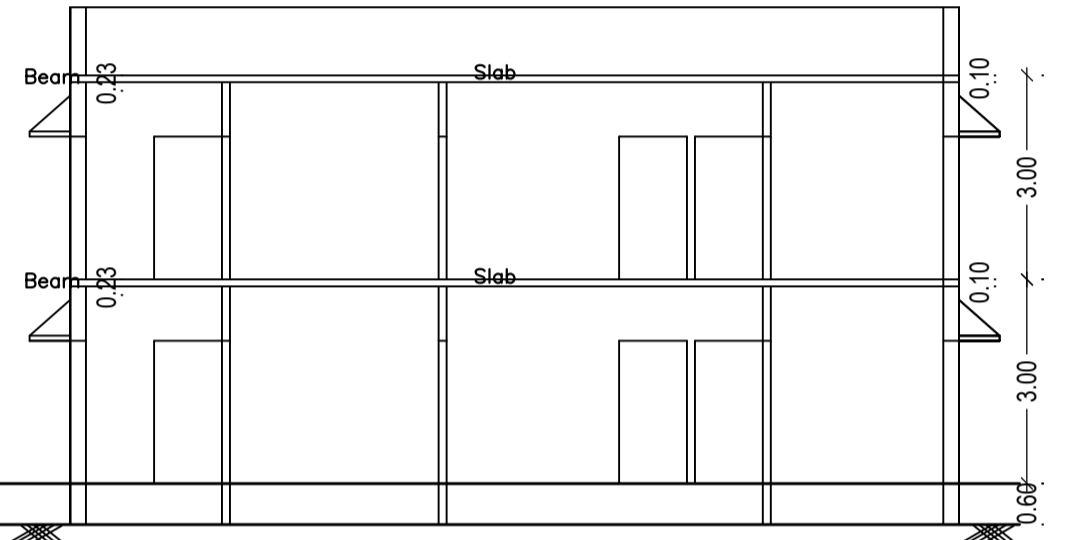
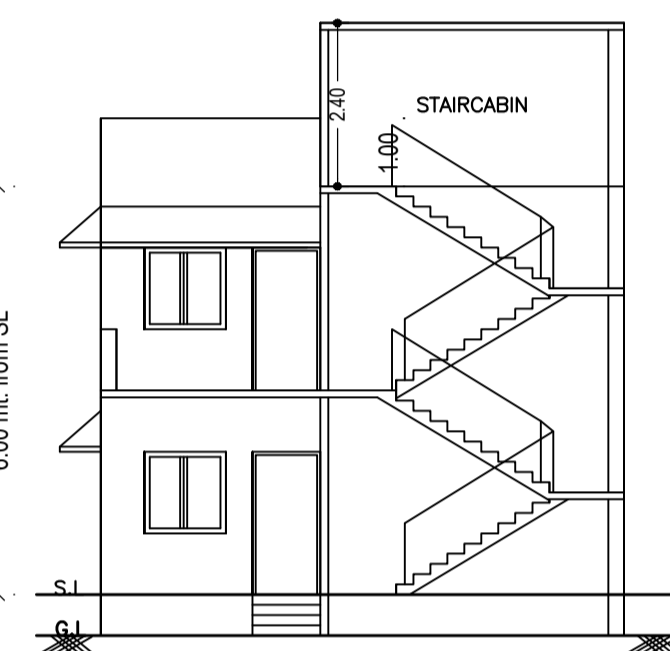
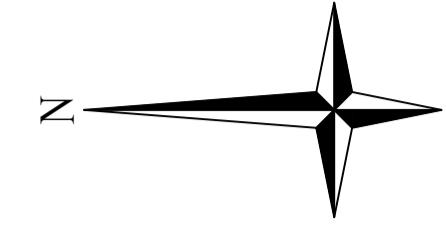
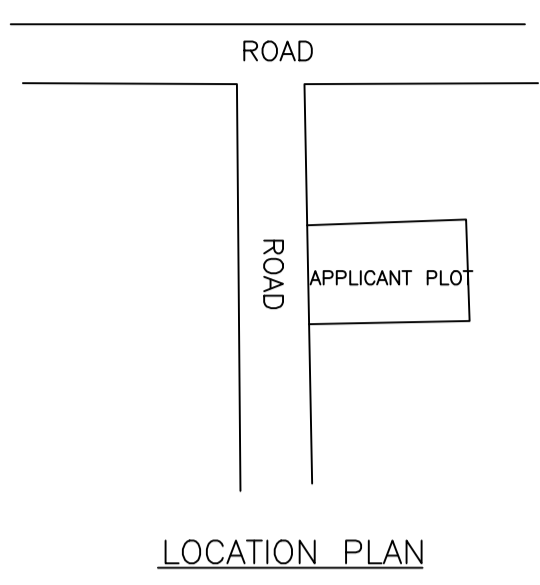
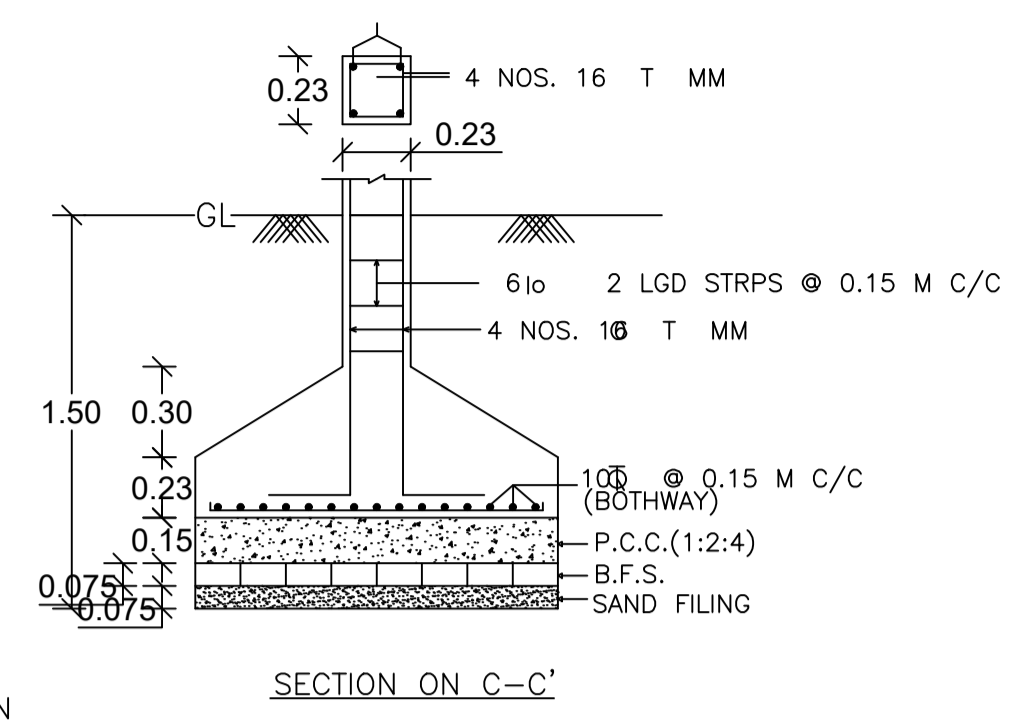

DETAILS OF WATER HARVESTING

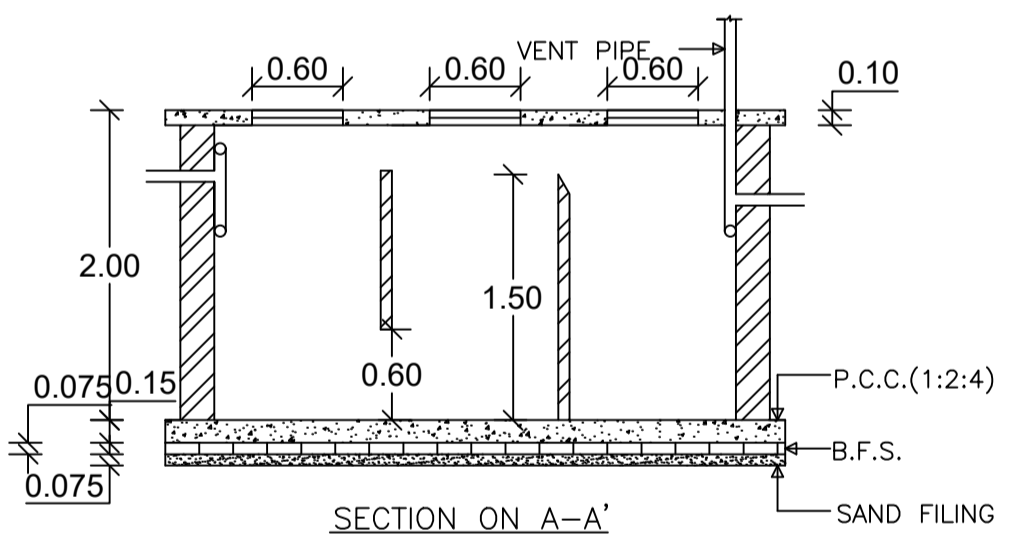
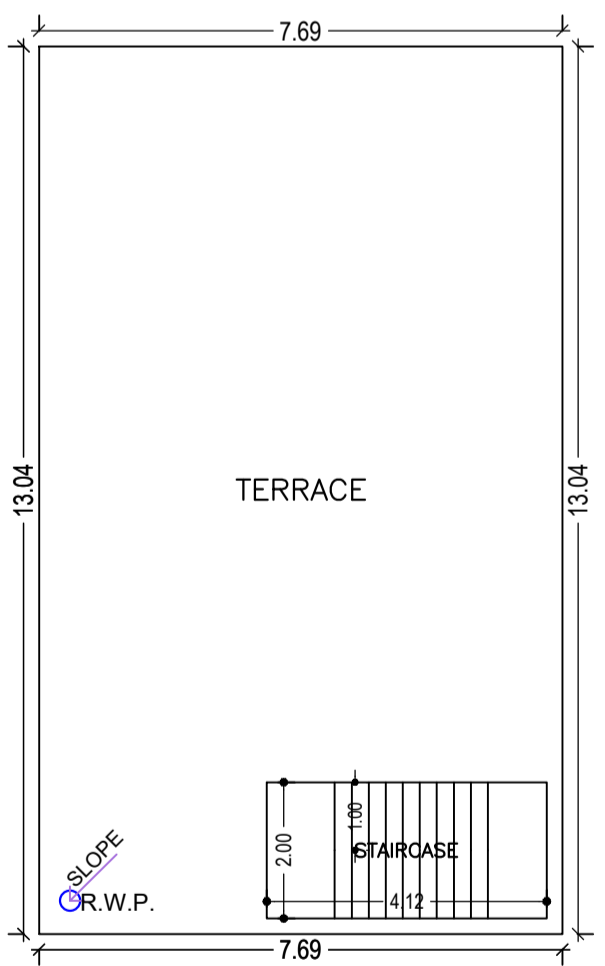
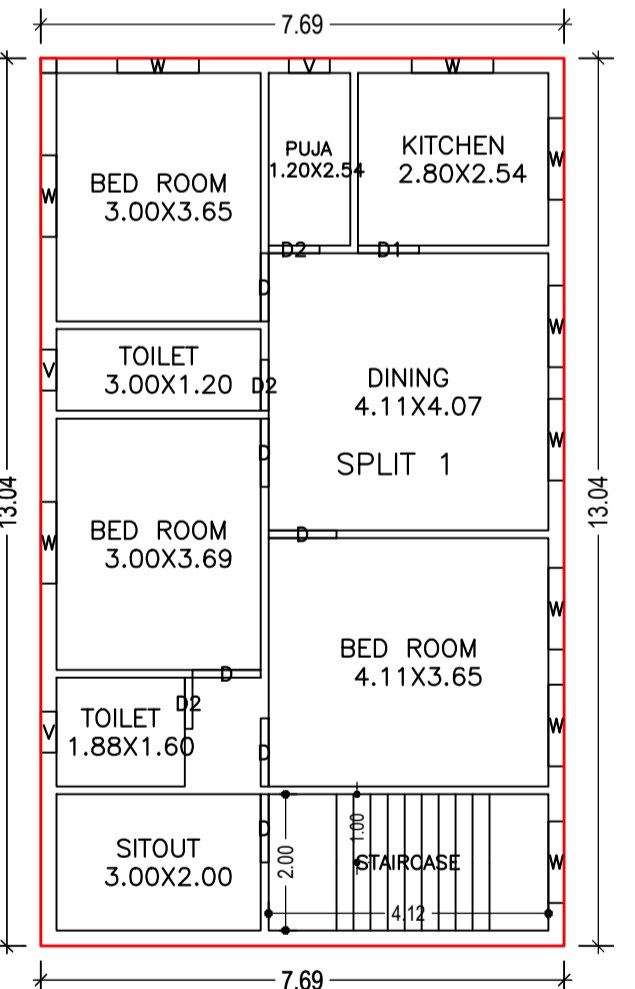
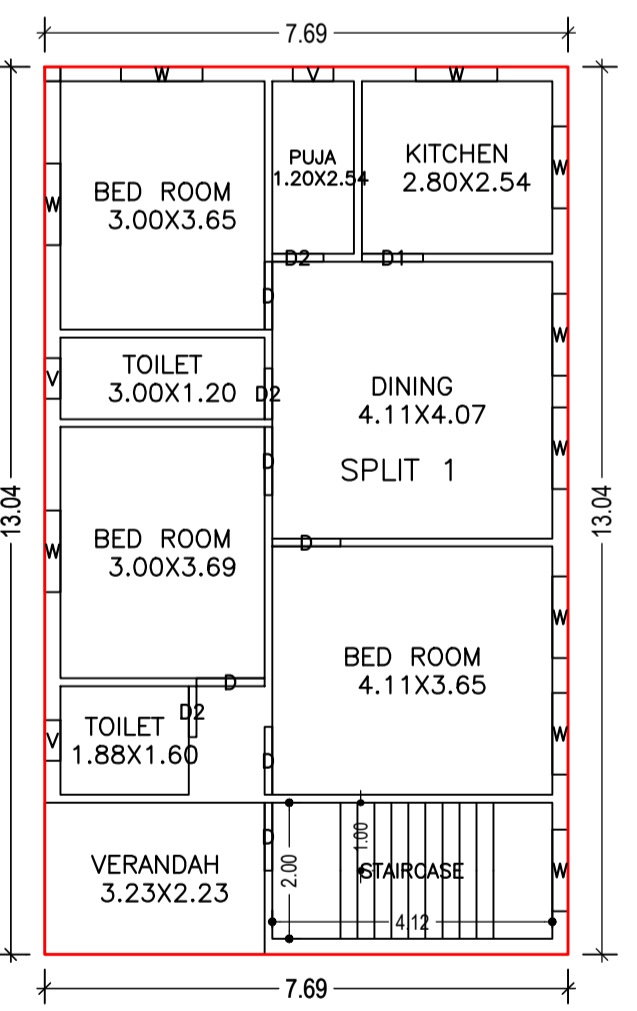
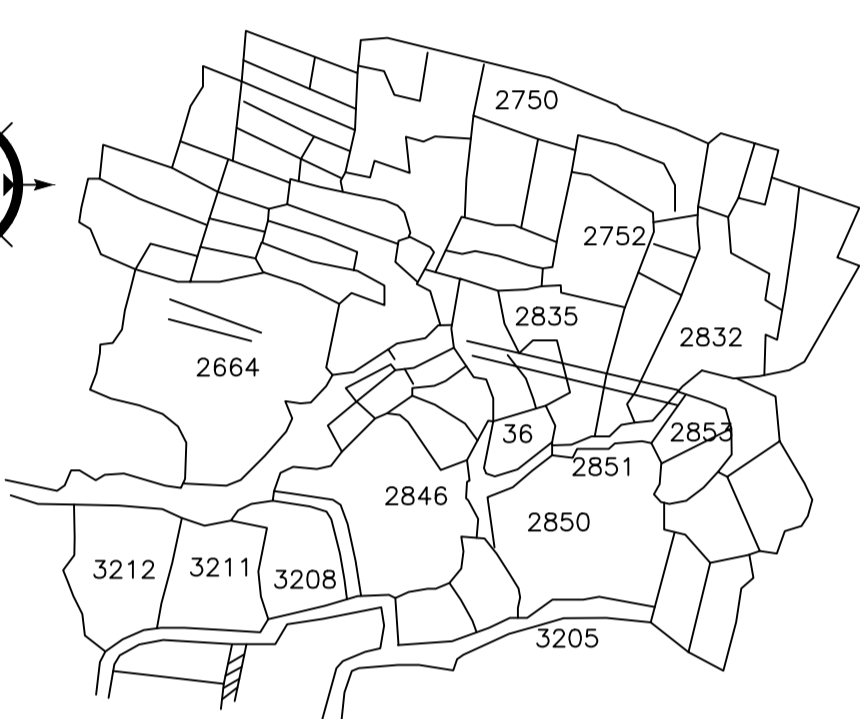
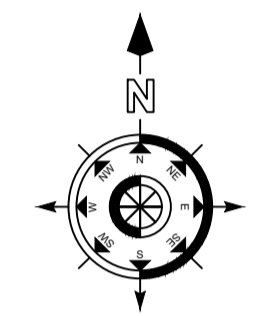
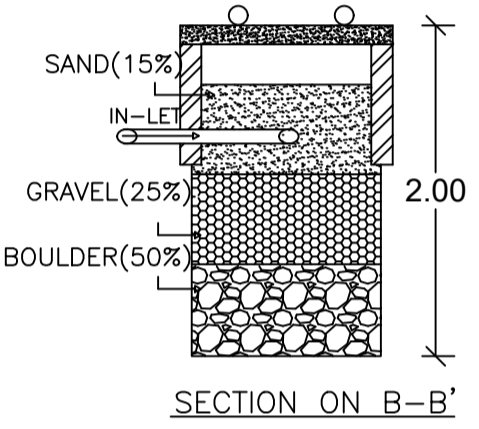

DETAILS OF SEPTIC TANK

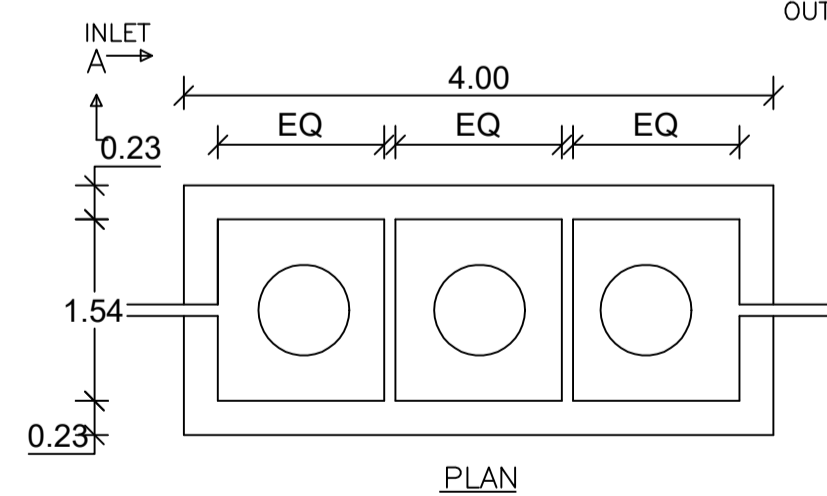

DETAILS OF SEPTIC TANK

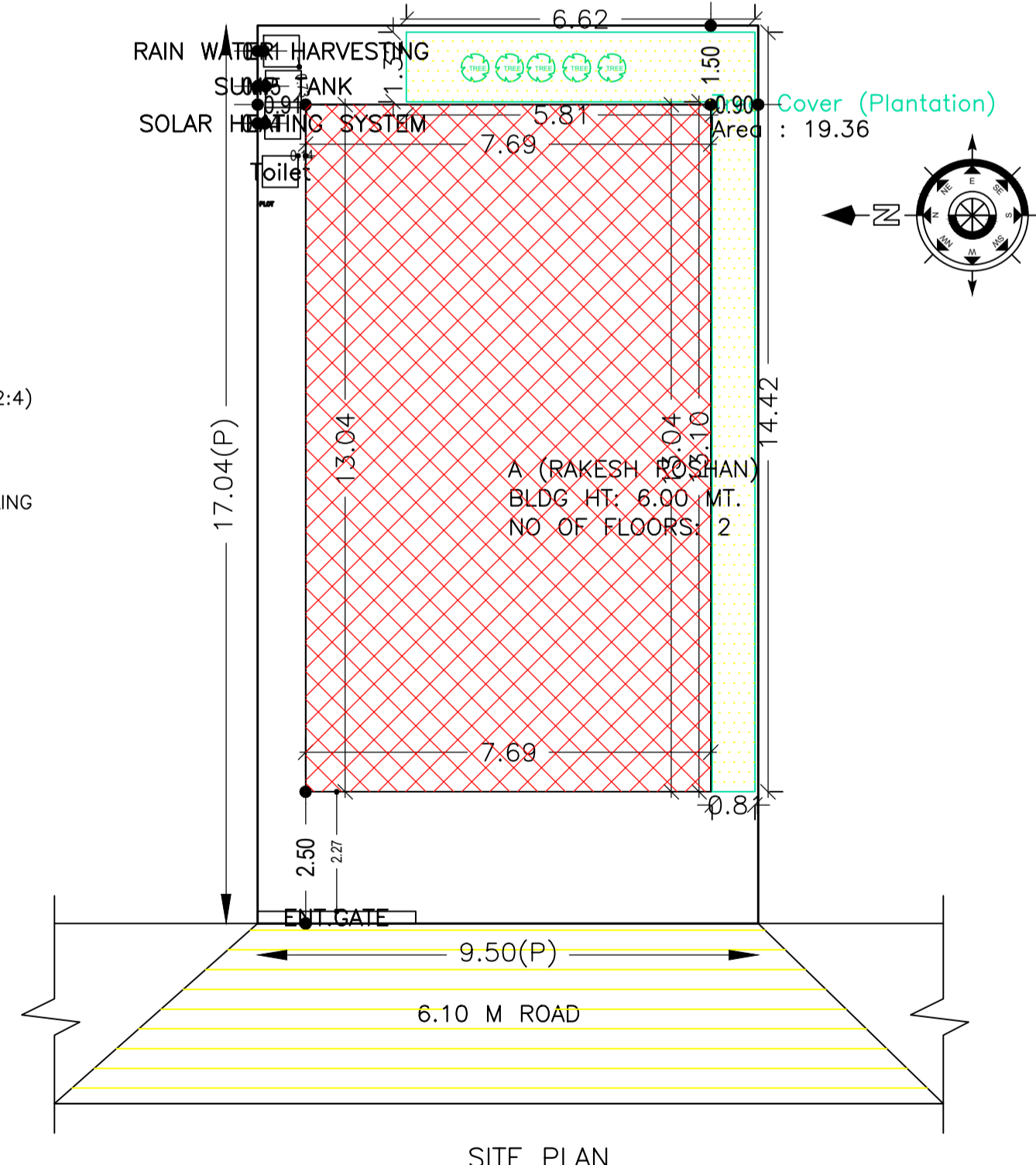

AREA STATEMENT CHAS MUNICIPAL CORPORATION	VERSION NO.: 1.0.68	VERSION DATE: 16/10/2020
PROJECT DETAIL:		
Region: JHARKHAND URBAN LOCAL BODIES	Plot Use: Residential	
District: BOKARO	Plot SubUse: Bungalow/ Dwelling / Non Apartment	
Authority: CHAS MUNICIPAL CORPORATION	PlotNearbyReligiousStructure: NA	
Inward No: CMC/BP/0328/W07/2021	Plot/SubPlot No: 2835 2836	
Application Type: General Proposal	North: Plot No. - SHASHI NAGAR	
Project Type: Building Permission	South: Plot No. - SHASHI NAGAR	
Nature of Development: New	East: Plot No. - SHASHI NAGAR	
Location of Development Area: Old Area	West: Road Width - 6.10 M ROAD	
AREA DETAILS:		
AREA OF PLOT (Minimum)	(A)	161.92
NET AREA OF PLOT (Gross Plot Area - Deduction from Gross Plot Area)	(A-Deductions)	161.92
Deduction for Balance Plot Area (from Gross Plot Area)		
Common Plot		19.36
Total		19.36
BALANCE AREA OF PLOT (Net Plot Area - Recreational/Amenity space)	(A-Deductions)	142.57
PLOT AREA FOR COVERAGE (Net Plot Area)	(A-Deductions)	161.92
Plot Area for FAR (Net Plot Area + Road Widening Area)	(A-Deductions)	161.92
COVERAGE CHECK		
Permissible Coverage area (70.00 %)		113.34
Proposed Coverage Area (61.95 %)		100.31
Total Prop. Coverage Area (61.95 %)		100.31
Balance coverage area (8.05 %)		13.03
FAR CHECK		
Perm. FAR Area (2.50)		404.80
Total Perm. FAR area		404.80
Residential FAR		200.63
Proposed FAR Area		200.63
Total Proposed FAR Area		200.63
Consumed FAR (Factor)		1.24
Balance FAR Area		204.17
BUILT UP AREA CHECK		
Total Proposed BuiltUp Area		200.62
ARCHITECT (Regd)		RAVI KUMAR
ENGINEER (Regd)		
SUPERVISOR (Regd)		
OWNER (Regd)		RAKESH ROSHAN AND SWETA KUMARI
DEVELOPMENT AUTHORITY LOCAL BODY		

FAR & Tenement Details (Table 4c-1)

Building	No. of Same Bldg	Total Built Up Area (Sq.mt.)	Proposed FAR Area (Sq.mt.)	Total FAR Area (Sq.mt.)	Total Consumed Additional FAR Area (Sq.mt.)	Tnmt (No.)
A (RAKESH ROSHAN)	1	200.62	200.62	200.62	200.62	01
Grand Total :	1	200.62	200.62	200.62	200.62	01

Buildingwise Floor FAR Details

Floor Name	Building Name A (RAKESH ROSHAN)		Total	
	Proposed Built Up Area (Sq.mt.)	Proposed FAR Area (Sq.mt.)	Total Proposed Built Up Area (Sq.mt.)	Total FAR Area (Sq.mt.)
Ground Floor	100.31	100.31	100.31	100.31
First Floor	100.31	100.31	100.31	100.31
Terrace Floor	0.00	0.00	0.00	0.00
Total :	200.62	200.62	200.62	200.62

COLOR INDEX

PLOT BOUNDARY	Black
ABUTTING ROAD	Green
PROPOSED CONSTRUCTION	Red
COMMON PLOT	Yellow
ROAD WIDENING AREA	Blue
EXISTING (To be retained)	Light Blue
EXISTING (To be demolished)	Light Yellow

Building :A (RAKESH ROSHAN)

Floor Name	Total Built Up Area (Sq.mt.)	Proposed FAR Area (Sq.mt.)	Total FAR Area (Sq.mt.)	Total Consumed Additional FAR Area (Sq.mt.)	Tnmt (No.)
Ground Floor	100.31	100.31	100.31	100.31	01
First Floor	100.31	100.31	100.31	100.31	00
Terrace Floor	0.00	0.00	0.00	0.00	00
Total :	200.62	200.62	200.62	200.62	01
Total Number of Same Buildings :	1				
Total :	200.62	200.62	200.62	200.62	01

SCHEDULE OF DOOR:

BUILDING NAME	NAME	LENGTH	HEIGHT	NOS
A (RAKESH ROSHAN)	D2	0.75	2.10	06
A (RAKESH ROSHAN)	D1	0.90	2.10	02
A (RAKESH ROSHAN)	D	1.00	2.10	12

SCHEDULE OF WINDOW/VENTILATION:

BUILDING NAME	NAME	LENGTH	HEIGHT	NOS
A (RAKESH ROSHAN)	V	0.60	1.20	06
A (RAKESH ROSHAN)	W	1.20	1.20	20

UnitBUA Table for Building :A (RAKESH ROSHAN)

FLOOR	Name	UnitBUA Type	UnitBUA Area	Carpet Area	No. of Rooms	No. of Tenement
GROUND FLOOR PLAN	SPLIT 1	FLAT	200.63	200.53	9	1
FIRST FLOOR PLAN	SPLIT 1	FLAT	0.00	0.00	9	0
Total:	-	-	200.63	200.53	18	1

Building USE/SUBUSE Details

Building Name	Building Use	Building SubUse	Building Structure
A (RAKESH ROSHAN)	Residential	Bungalow/ Dwelling / Non Apartment	Non-Highrise

LTP NAME AND SIGNATURE	STRUCTURAL ENG'S NAME AND SIGNATURE	BUILDER NAME AND SIGNATURE	DIGITAL SIGNATURE
RAVI KUMAR CMC/DFTM/0024/2017			