

Project Title : SANQJ KUMAR

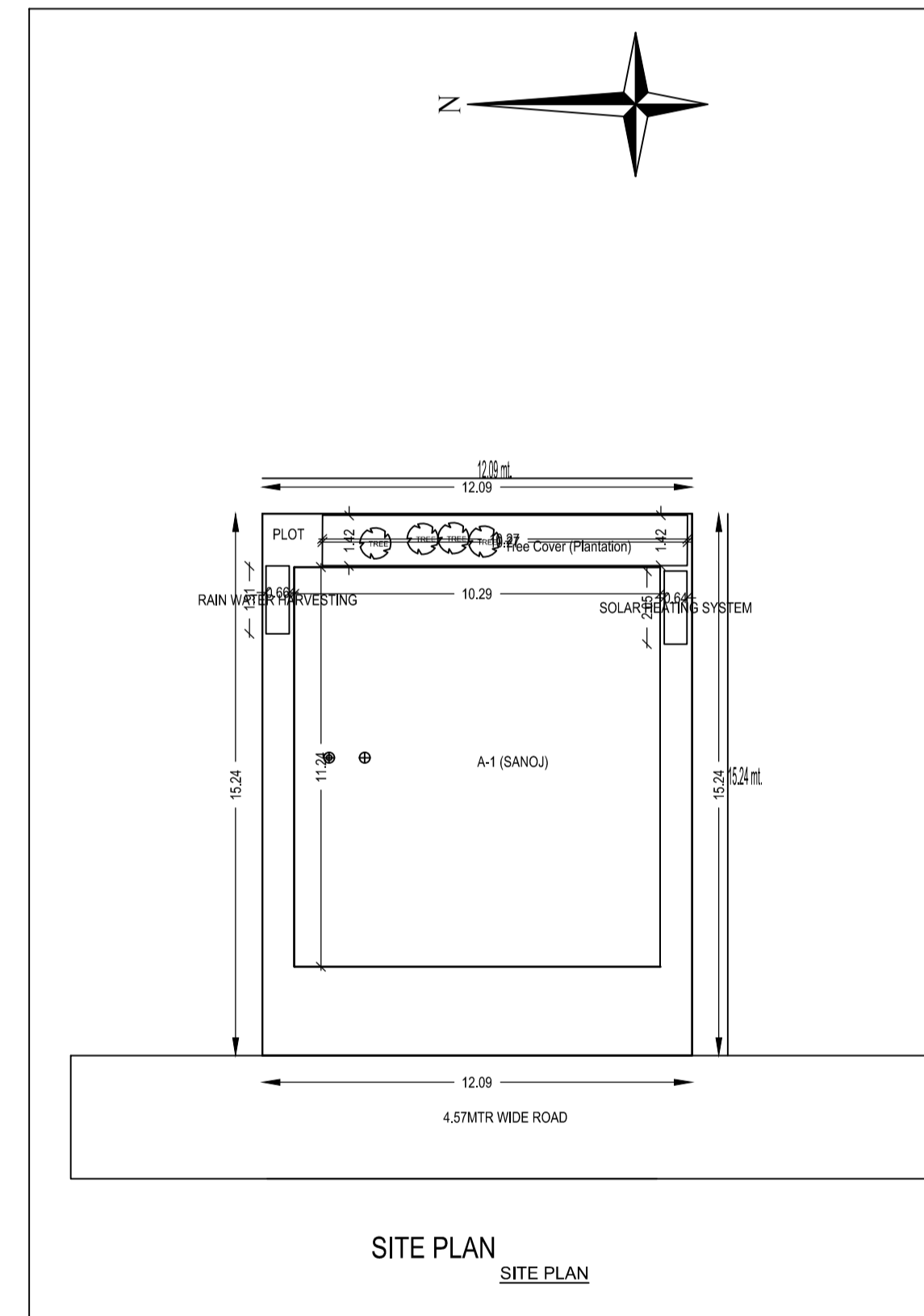
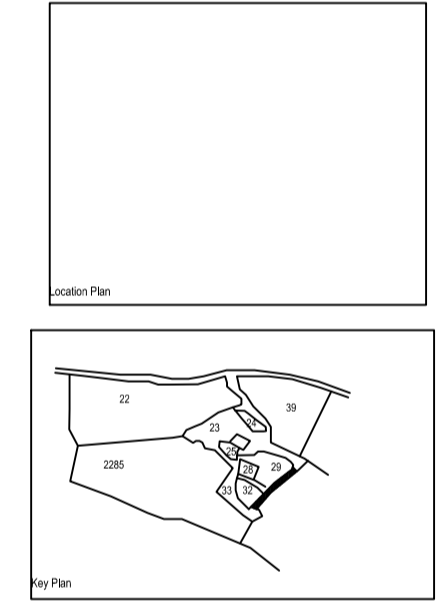
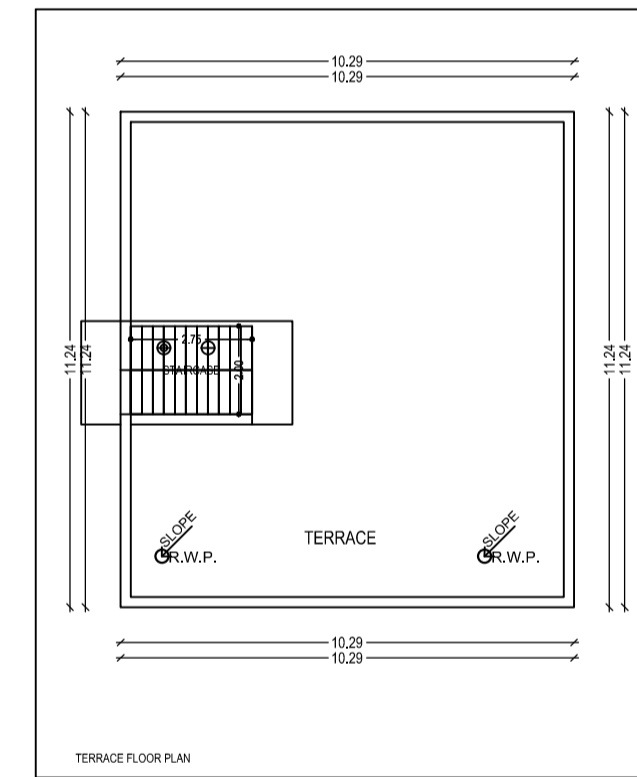
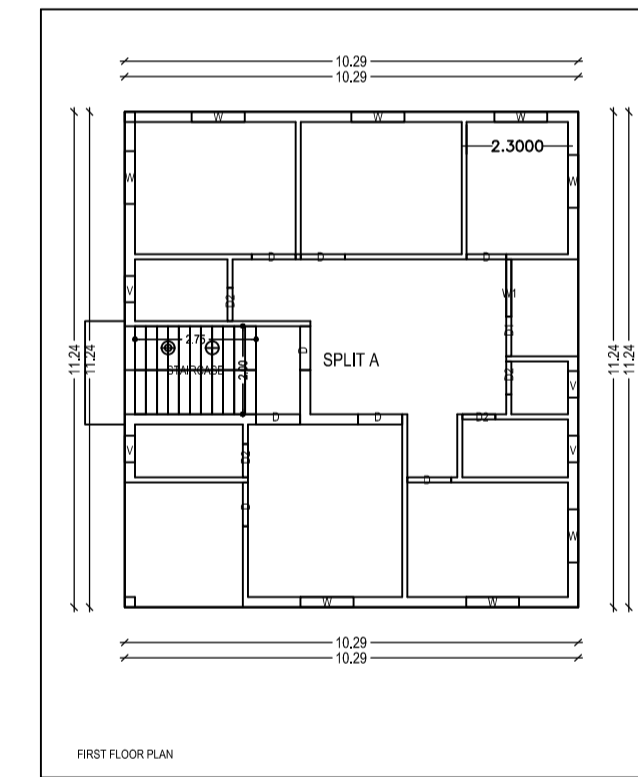
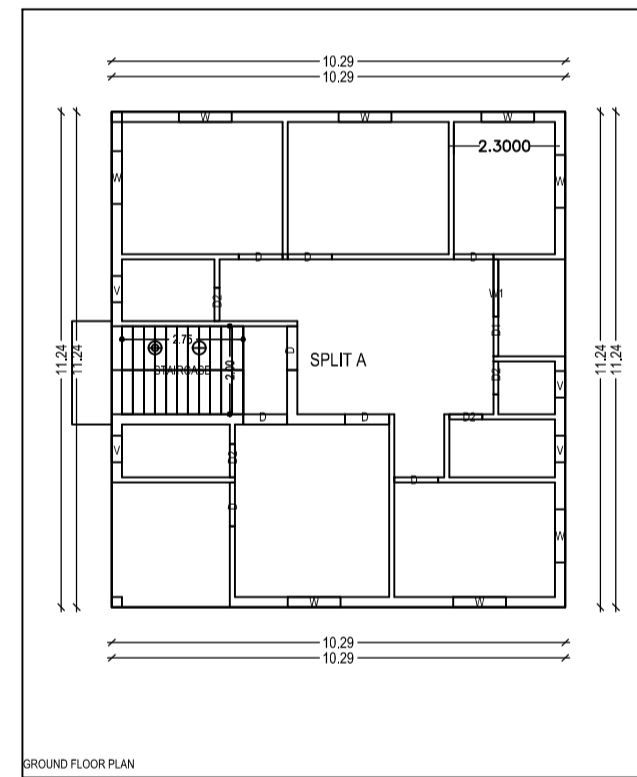
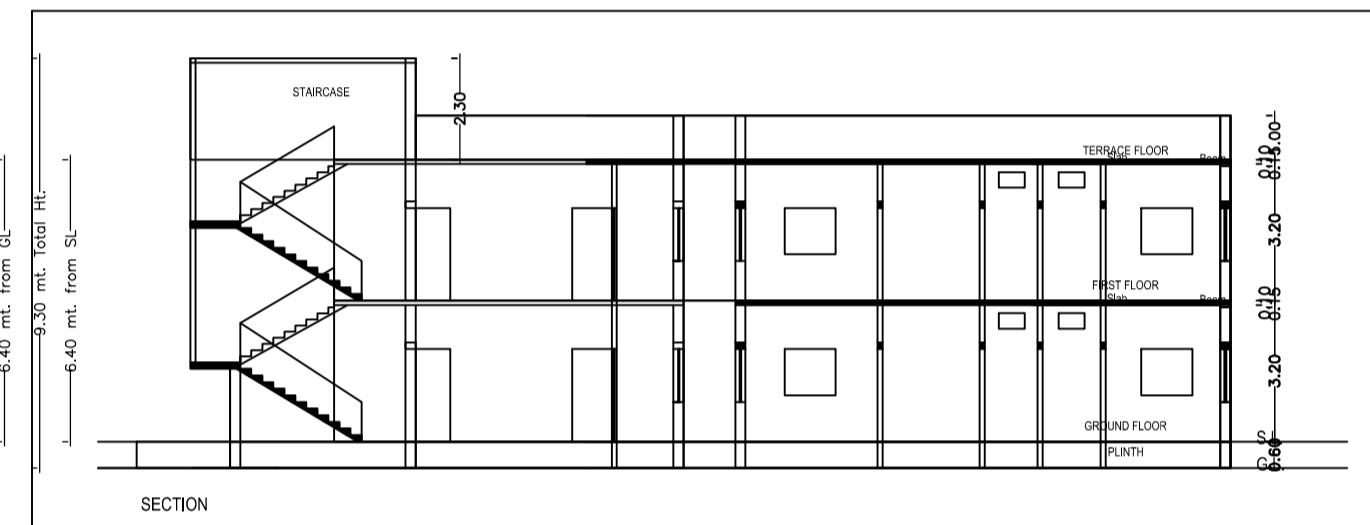
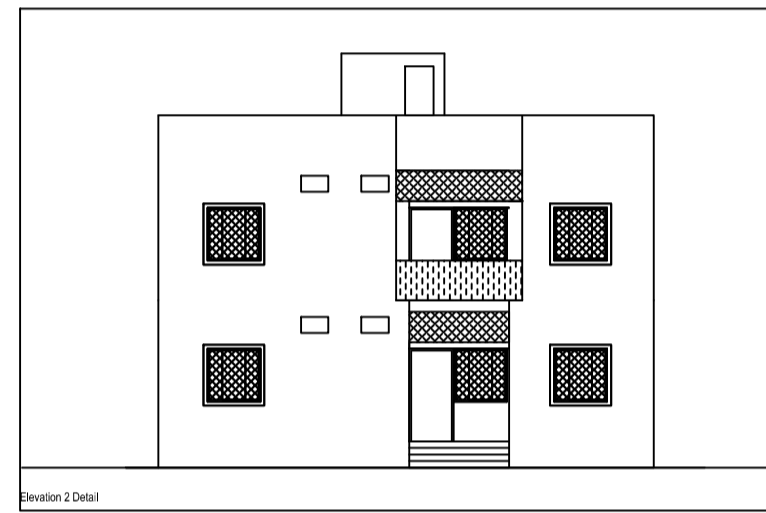
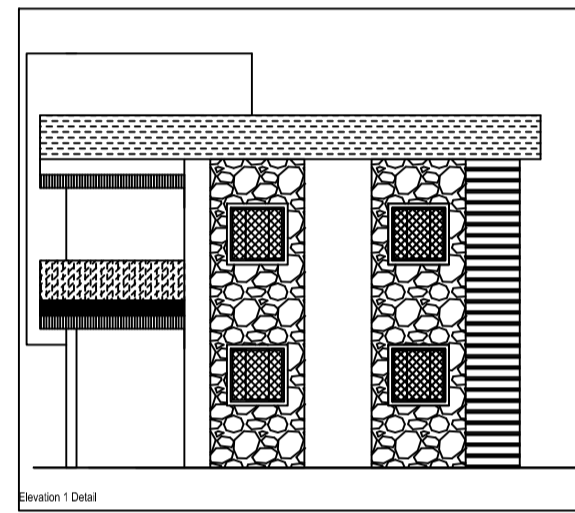
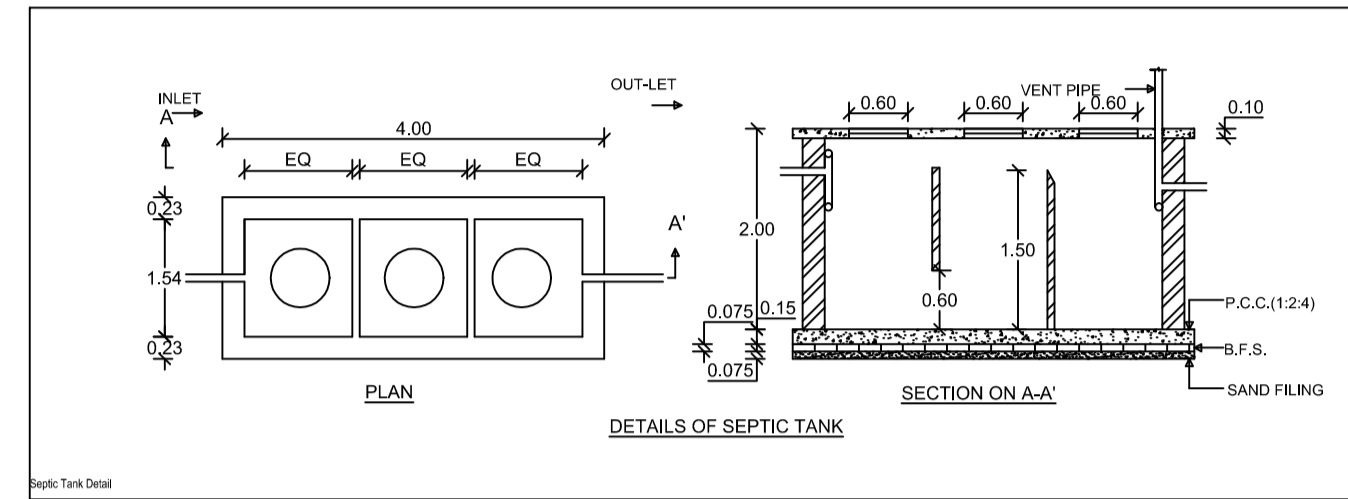
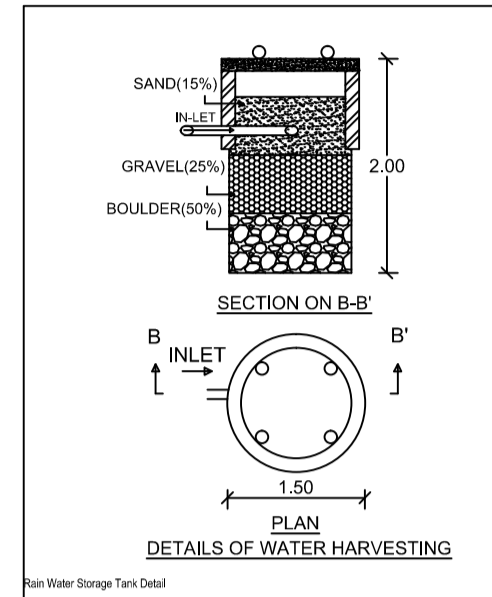
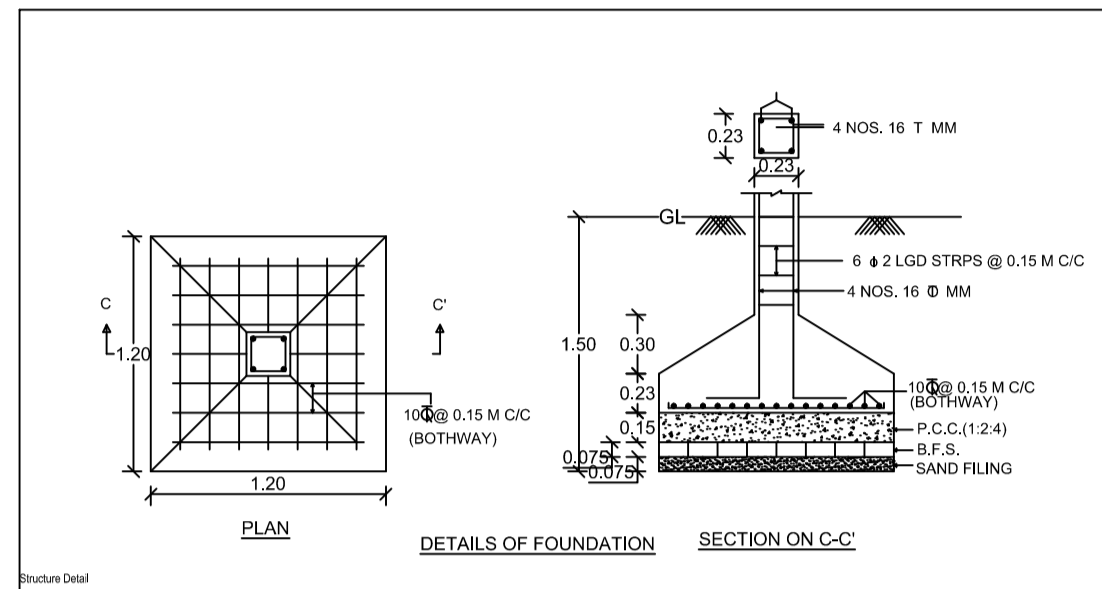

AREA STATEMENT - CHAS MUNICIPAL CORPORATION	VERSION NO. 1.038
PROJECT DETAIL	VERSION DATE: 16/10/2020
Project No. -	Plot Use - Residential
Region - PUNJAB/URBANOCC BOOBS	Plot Subtype - Residential / Non-Apartment
Project Name -	Land Use Code - R4
Application Type - General Proposal	Building Road Width -
Project Type - Building Permission	Plot No. -
Nature of Development - New	Formal Survey No/Survey No -
Location - Old Area	Town No. -
Site Location -	Plotting No. -
Village/Munici Name -	Khata No. -
North -	North -
Road/Street -	South -
Water -	East -
West -	West -

AREA DETAILS	
AREA OF PLOT (Minimum)	24
Net PFC Area (Gross PFC Area - Deductions from Gross PFC Area)	184.25
Deductions for Balance PFC Area from Gross PFC Area	184.25
COF Area	184.25
COF Area	184.25
Balance PFC Area (Net PFC Area - Deductions)	184.25
PFC Area for Coverage (Net PFC Area - Deductions)	184.25
PFC Area for FUR (Net PFC Area - Deductions)	184.25
Proposed Coverage Area (E2/F1 %)	115.06
Total Coverage Area (E2/F1 %)	115.06
TANK CHECK	231.32
Proposed Area of FAR	231.32
Total Area of FAR	231.32
SOFT TOP FLOOR CHECK	231.32
Total Proposed Built up Area	231.32
ARCHITECT/ENGINEER/SUPPLY BODY (Sign)	OWNER
DEVELOPMENT AUTHORITY	LOCAL BODY

COLOR INDEX					
PLANT SHADING	AS	SWIFT	184.25		
PROPOSED WORK COVERAGE AREA	(A-Deductions)		184.25		
EXISTING (To be retained)					
EXISTING (To be demolished)					

MARGIN DETAILS					
Side Margin	2.00	1.50	0.60	0.60	

FAR & Tenement Details (Table 4c-1)					
Building	No. of Same Bldg	Total Built up Area (Sq.m)	Proposed FAR Area (Sq.m)	Total FAR Area (Sq.m)	Front Setback
A (SANQJ)	1	231.32	231.32	231.32	01
Grand Total	1	231.32	231.32	231.32	01

Building -A (SANQJ)				
Floor Name	Total Built up Area (Sq.m)	Proposed FAR Area (Sq.m)	Total FAR Area (Sq.m)	Type (No.)
Ground Floor	115.06	115.06	115.06	01
First Floor	115.06	115.06	115.06	02
Terrace Floor	0.00	0.00	0.00	00
Total	231.32	231.32	231.32	01
Total Number of Same Buildings	1			
Total	231.32	231.32	231.32	01

SCHEDULE OF JOINERY:				
BUILDING NAME	NAME	LENGTH	HEIGHT	NO. OF
A (SANQJ)	01	0.75	2.10	08
A (SANQJ)	01	0.80	2.10	02
A (SANQJ)	01	0.80	2.10	02
A (SANQJ)	D	1.20	2.10	14
Total	-	-	-	26

SCHEDULE OF JOINERY:				
BUILDING NAME	NAME	LENGTH	HEIGHT	NO. OF
A (SANQJ)	V	0.60	1.00	08
A (SANQJ)	W	1.20	1.20	16
A (SANQJ)	WT	1.20	1.20	02
Total	-	-	-	26

UNUSUAL Table for Building -A (SANQJ)						
FLOOR	Name	UNUSUAL Type	UNUSUAL Area	Claret Area	No. of Rooms	No. of Tenement
GROUND FLOOR	SPLIT A	PLAT	231.32	231.32	14	1
Total	-	-	231.32	231.32	14	1