

Proposal Basic Information

Proposal File No.	CMC/BP/0036/W04/2021
Owner Name	BHANUPRIYA SINGH
Khata No	580
Plot No	1417
Village Name	Chas
Use	Residential
SubUse	Bungalow/ Dwelling / Non Apartment

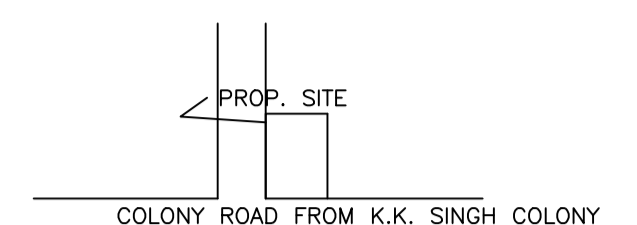

AREA STATEMENT CHAS MUNICIPAL CORPORATION	VERSION NO : 1.0.54	SQ. MT.
PROJECT DETAIL:	VERSION DATE: 16/10/2020	
Region: JHARKHAND URBAN LOCAL BODIES	Plot Use: Residential	
District: BOKARO	Plot SubUse: Bungalow/ Dwelling / Non Apartment	
Authority: CHAS MUNICIPAL CORPORATION	PlotNearbyReligiousStructure: NA	
Inward No: CMC/BP/0036/W04/2021	PlotSubPlot No: 1417	
Application Type: General Proposal	North: Road Width - ROAD	
Project Type: Building Permission	South: Plot No. - PLOT NO. - 1417	
Nature of Development: New	East: Plot No. - PLOT NO. - 1417	
Location of Development Area: Old Area	West: Road Width - ROAD	
AREA DETAILS:		
AREA OF PLOT (Minimum)	(A)	250.22
NET AREA OF PLOT(Gross Plot Area - Deduction from Gross Plot area)	(A-Deductions)	250.22
Deduction for Balance Plot Area(from Gross Plot Area)		
Common Plot		20.67
Total		20.67
BALANCE AREA OF PLOT(Net Plot Area - Recreational/Amenity space)	(A-Deductions)	229.55
PLOT AREA FOR COVERAGE(Net Plot Area)	(A-Deductions)	250.22
Plot Area for FAR (Net Plot Area + Road Widening Area)	(A-Deductions)	250.22
COVERAGE CHECK		
Permissible Coverage area (60.00 %)		150.13
Proposed Coverage Area (39.69 %)		99.30
Total Prop. Coverage Area (39.69 %)		99.30
Balance coverage area (20.31 %)		50.83
FAR CHECK		
Perm. FAR Area (2.50)		625.55
Total Perm. FAR area		625.55
Residential FAR		185.83
Proposed FAR Area		185.83
Total Proposed FAR Area		185.83
Consumed FAR (Factor)		0.74
Balance FAR Area		439.72
BUILT UP AREA CHECK		
Total Proposed BuiltUp Area		185.83
ARCHITECT (Regd)		AMRIT KUMAR MAHATO
ENGINEER (Regd)		
SUPERVISOR (Regd)		
OWNER (Regd)		BHANUPRIYA SINGH
DEVELOPMENT AUTHORITY		LOCAL BODY

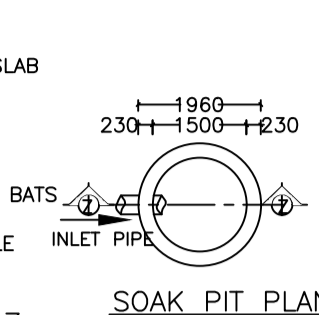
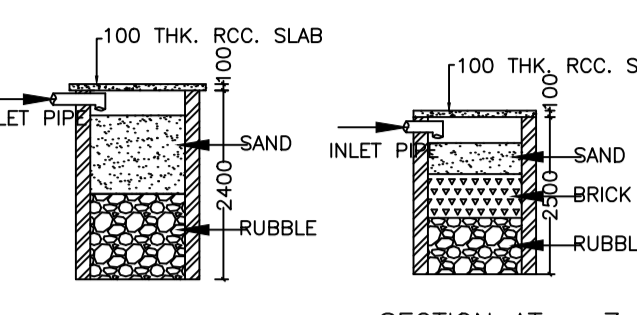
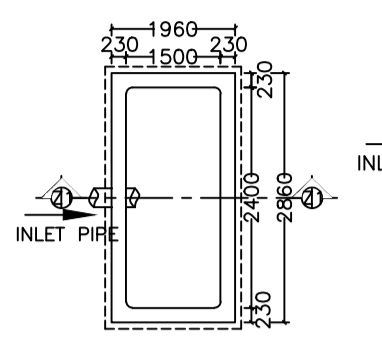
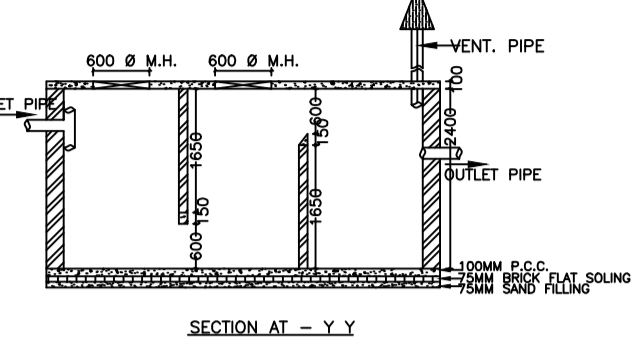
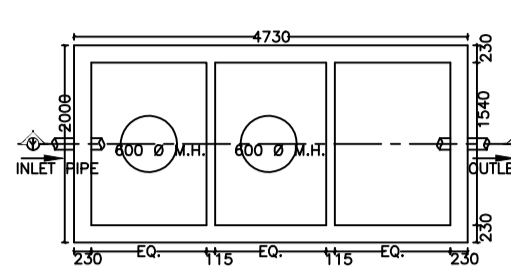
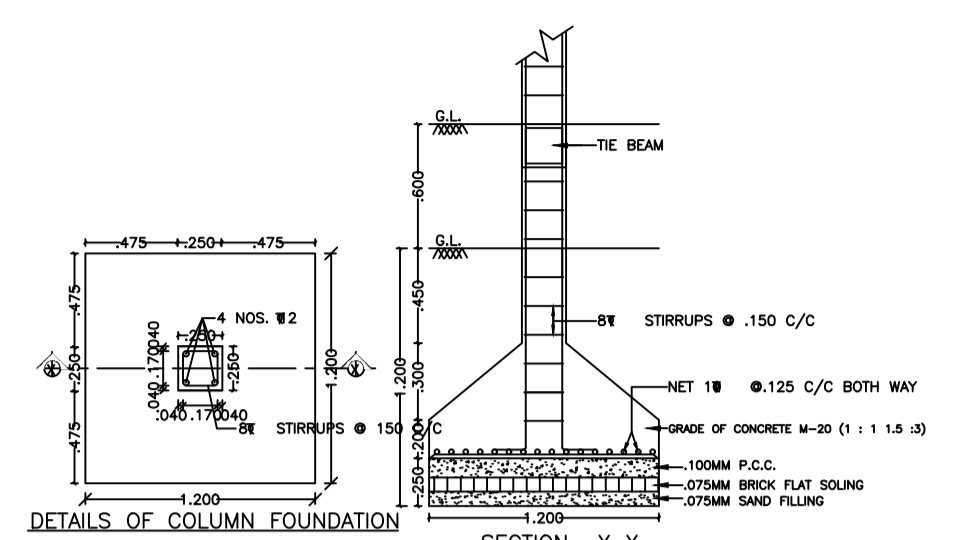
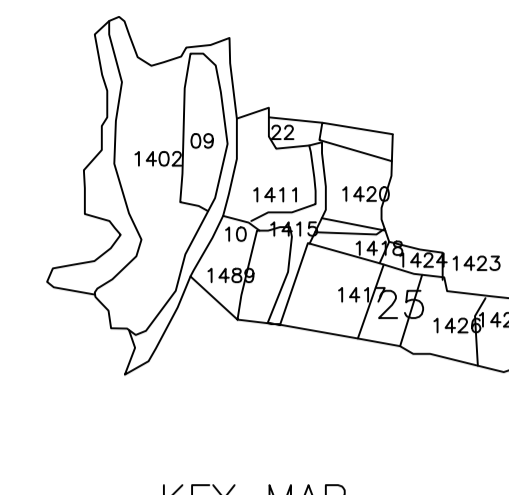
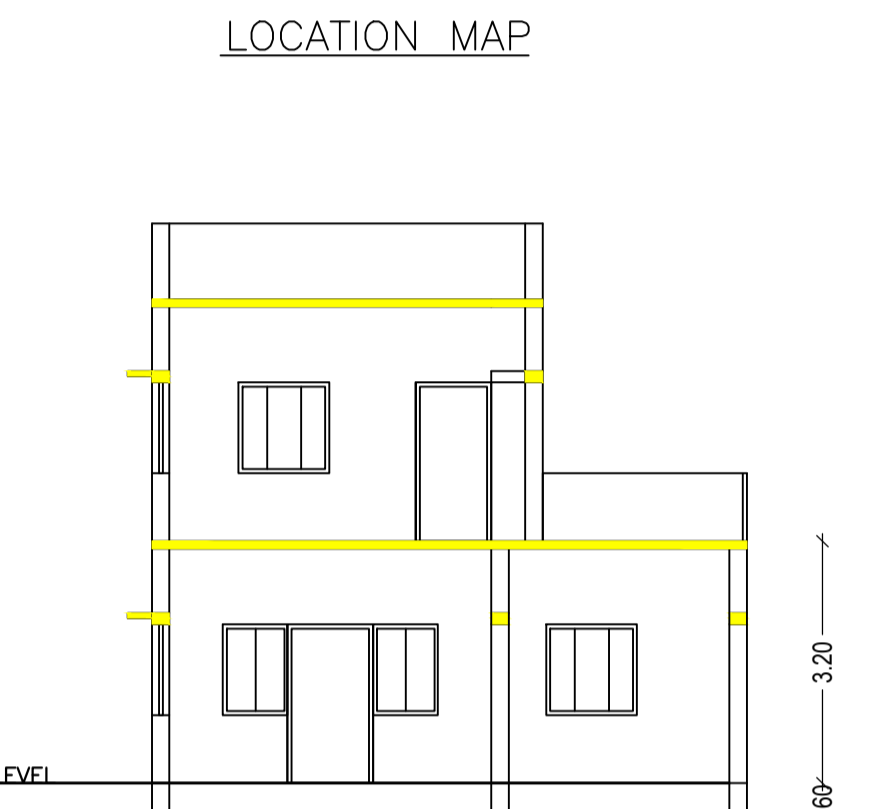
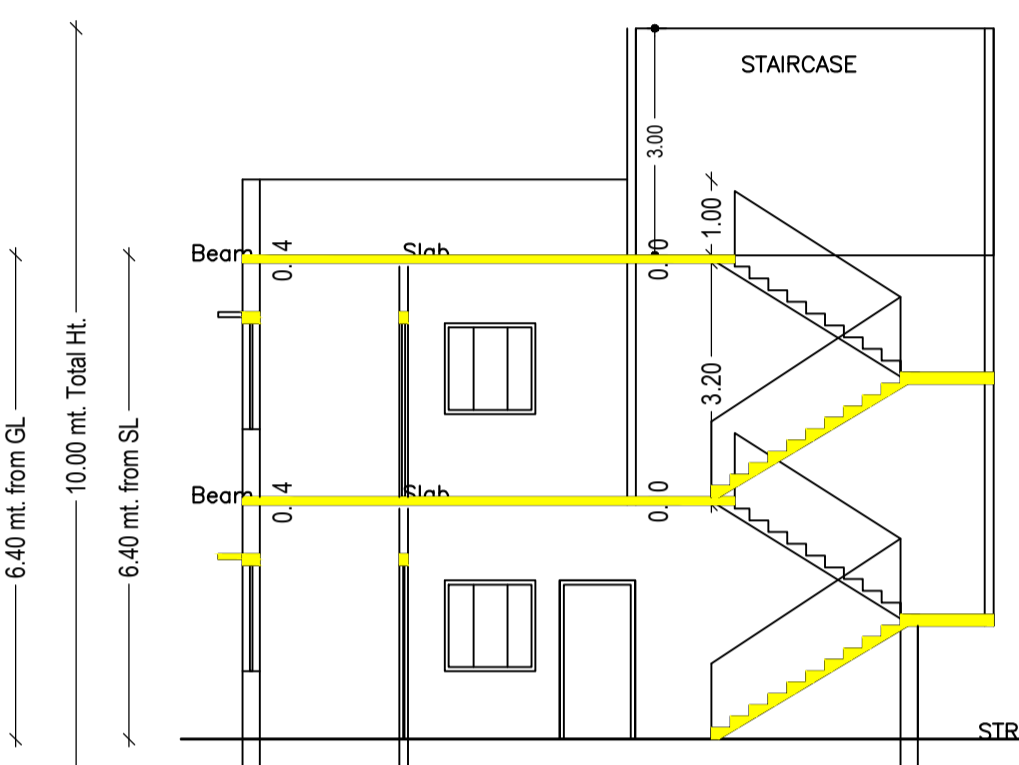
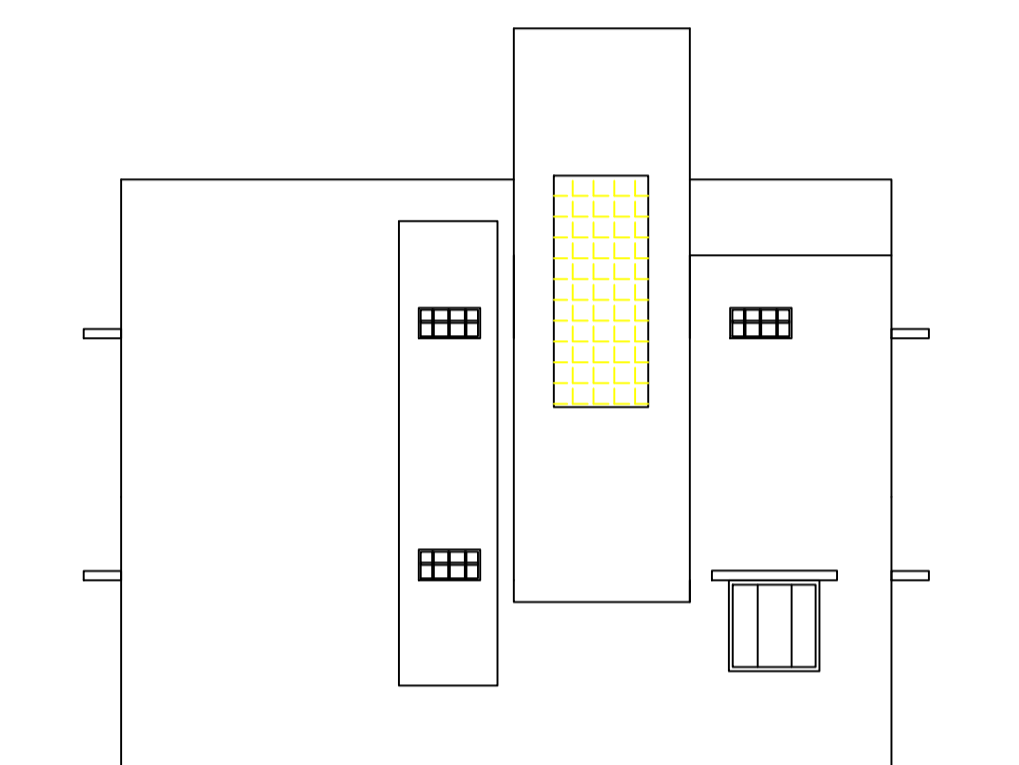
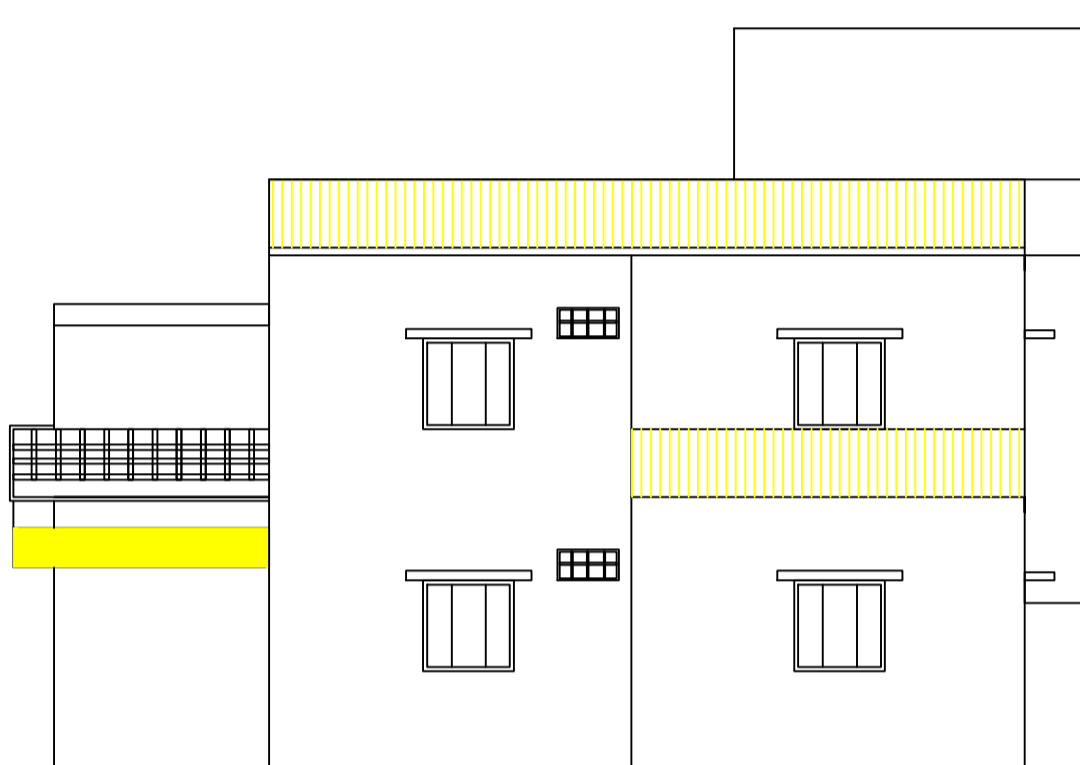

FRONT ELEVATION

SIDE ELEVATION

SECTION AT-A-A

SECTION AT-B-B

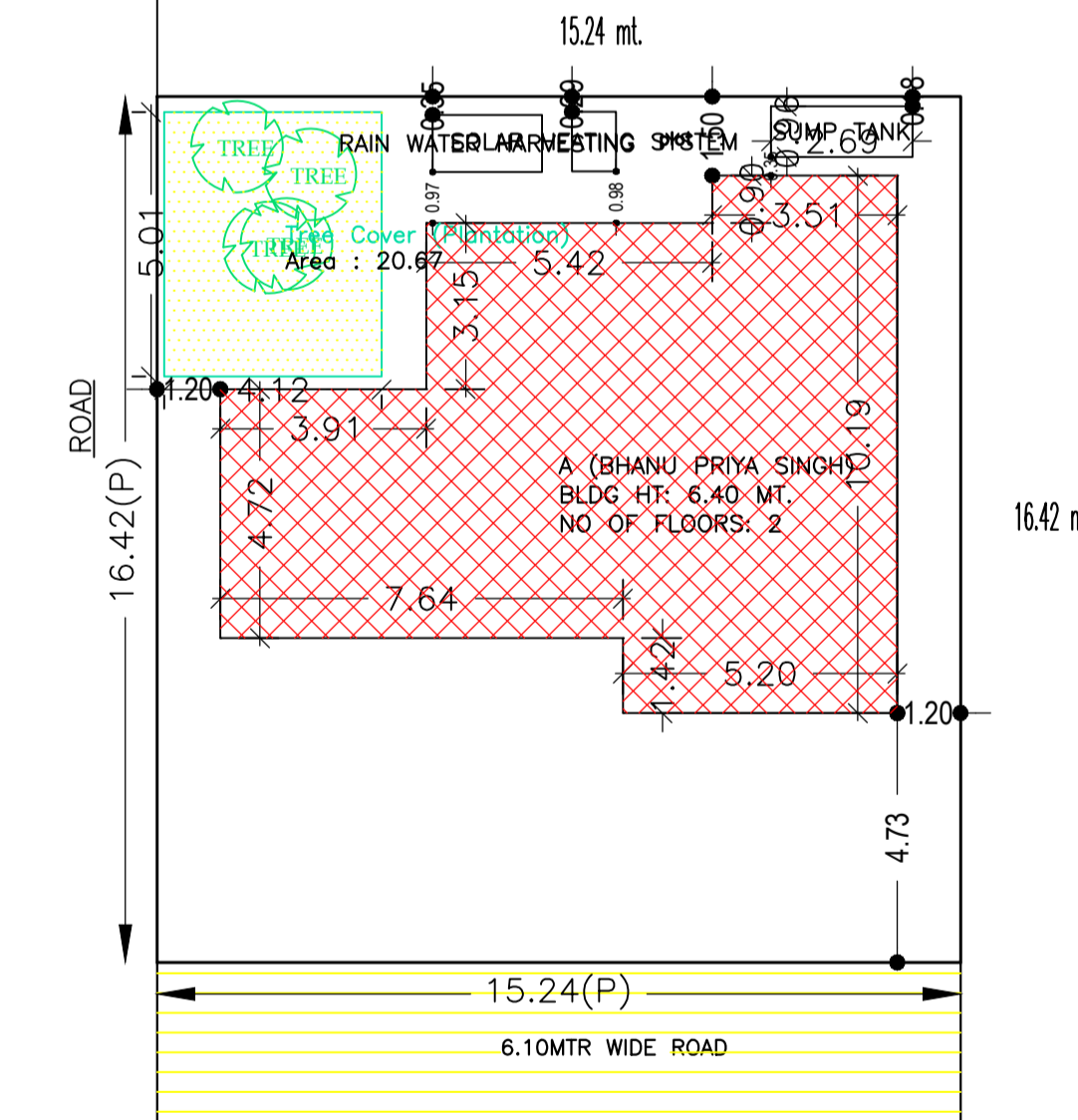
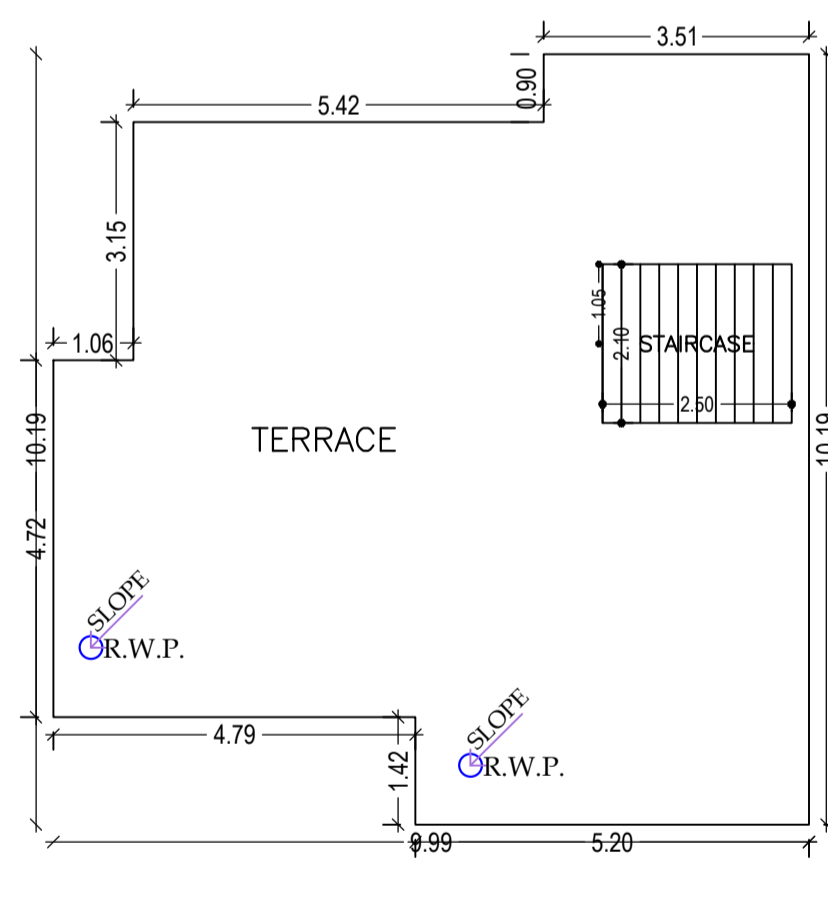
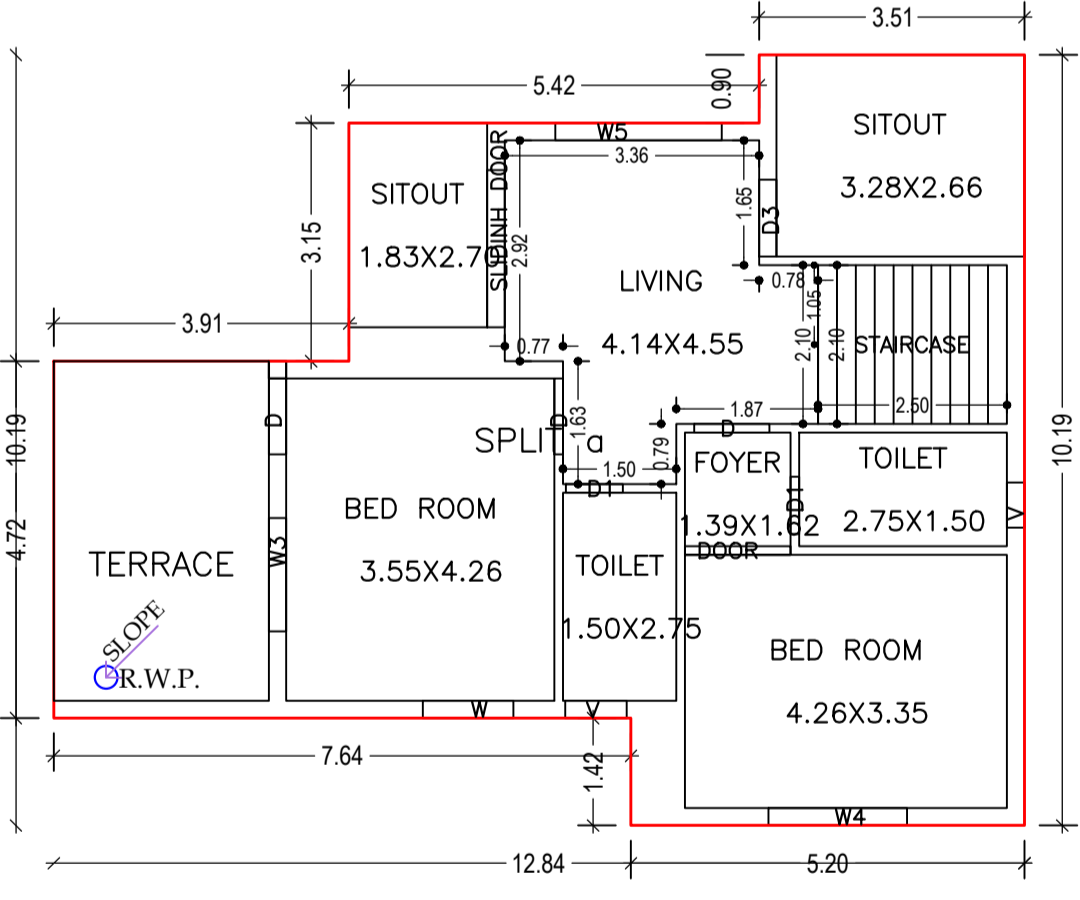
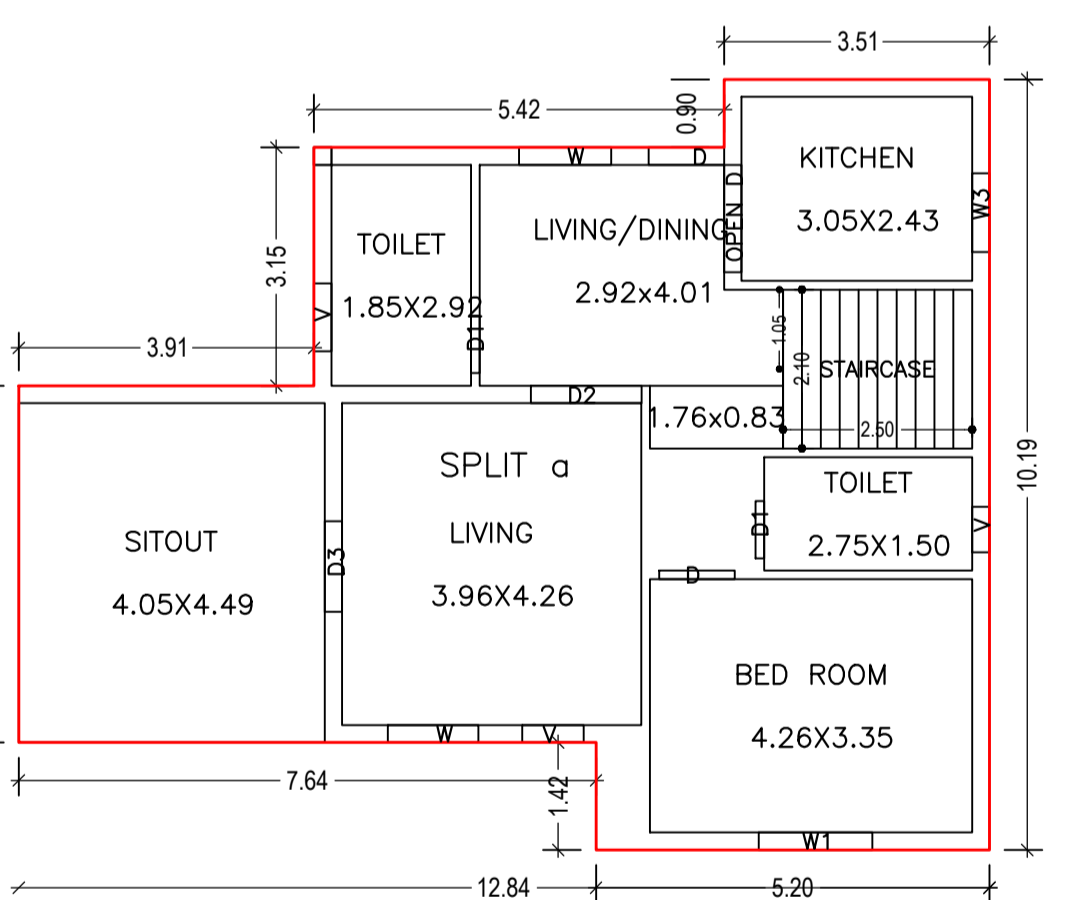

GROUND FLOOR PLAN (Proposed) (SCALE 1:100)

FIRST FLOOR PLAN (Proposed) (SCALE 1:100)

TERRACE FLOOR PLAN (SCALE 1:100)

SITE PLAN

Buildingwise Floor FAR Details

Floor Name	Building Name		Total	
	Proposed Built Up Area (Sq.mt.)	Proposed FAR Area (Sq.mt.)	Total Proposed Built Up Area (Sq.mt.)	Total FAR Area (Sq.mt.)
Ground Floor	99.30	99.30	99.30	99.30
First Floor	86.53	86.53	86.53	86.53
Terrace Floor	0.00	0.00	0.00	0.00
Total :	185.83	185.83	185.83	185.83

FAR & Tenement Details (Table 4c-1)

Building	No. of Same Bldg	Total Built Up Area (Sq.mt.)	Proposed FAR Area (Sq.mt.)	Total FAR Area (Sq.mt.)	Total Consumed Additional FAR Area (Sq.mt.)	Tnmt (No.)
A (BHANU PRIYA SINGH)	1	185.83	185.83	185.83	185.83	01
Grand Total :	1	185.83	185.83	185.83	185.83	01

UnitBUA Table for Building :A (BHANU PRIYA SINGH)

FLOOR	Name	UnitBUA Type	UnitBUA Area	Carpet Area	No. of Rooms	No. of Tenement
GROUND FLOOR PLAN	SPLIT a	FLAT	185.17	185.07	7	1
FIRST FLOOR PLAN	SPLIT a	FLAT	0.00	0.00	8	0
Total:	-	-	185.17	185.07	15	1

Building USE/SUBUSE Details

Building Name	Building Use	Building SubUse	Building Structure
A (BHANU PRIYA SINGH)	Residential	Bungalow/ Dwelling / Non Apartment	Non-Highrise

COLOR INDEX	
PLOT BOUNDARY	[Red Line]
ABUTTING ROAD	[Green Line]
PROPOSED CONSTRUCTION	[Blue Line]
COMMON PLOT	[Yellow Line]
ROAD WIDENING AREA	[Orange Line]
EXISTING (To be retained)	[Grey Line]
EXISTING (To be demolished)	[Black Line]

LTP NAME AND SIGNATURE	STRUCTURAL ENG'S NAME AND SIGNATURE	BUILDER NAME AND SIGNATURE	DIGITAL SIGNATURE
AMRIT KUMAR MAHATO CMC/DFTM/0004/2019			

Building :A (BHANU PRIYA SINGH)

Floor Name	Total Built Up Area (Sq.mt.)	Proposed FAR Area (Sq.mt.)	Total FAR Area (Sq.mt.)	Total Consumed Additional FAR Area (Sq.mt.)	Tnmt (No.)
Ground Floor	99.30	99.30	99.30	99.30	01
First Floor	86.53	86.53	86.53	86.53	00
Terrace Floor	0.00	0.00	0.00	0.00	00
Total :	185.83	185.83	185.83	185.83	01

SCHEDULE OF DOOR:

BUILDING NAME	NAME	LENGTH	HEIGHT	NOS
A (BHANU PRIYA SINGH)	D1	0.76	2.10	04
A (BHANU PRIYA SINGH)	D	1.00	2.10	06
A (BHANU PRIYA SINGH)	D3	1.02	2.10	01
A (BHANU PRIYA SINGH)	D3	1.20	2.10	01
A (BHANU PRIYA SINGH)	DOOR	1.40	2.10	01
A (BHANU PRIYA SINGH)	OPEN D	1.42	2.10	01
A (BHANU PRIYA SINGH)	D2	1.46	2.10	01
A (BHANU PRIYA SINGH)	SLEIGH DOOR	2.08	2.10	01

SCHEDULE OF WINDOW/VENTILATION:

BUILDING NAME	NAME	LENGTH	HEIGHT	NOS
A (BHANU PRIYA SINGH)	V	0.60	1.20	02
A (BHANU PRIYA SINGH)	V	0.81	1.20	02
A (BHANU PRIYA SINGH)	V	0.90	1.20	01
A (BHANU PRIYA SINGH)	W3	1.04	1.20	01
A (BHANU PRIYA SINGH)	W	1.20	1.20	02
A (BHANU PRIYA SINGH)	W	1.22	1.20	01
A (BHANU PRIYA SINGH)	W3	1.50	1.20	01
A (BHANU PRIYA SINGH)	W1	1.50	1.20	01
A (BHANU PRIYA SINGH)	W4	1.83	1.20	01
A (BHANU PRIYA SINGH)	W5	2.20	1.20	01