

Proposal Basic Information

Proposal File No.	CMC/BP/0001/W07/2021
Owner Name	RINA DEVI
Khata No	724
Plot No	3485
Village Name	Chas
Use	Residential
SubUse	Bungalow/ Dwelling / Non Apartment

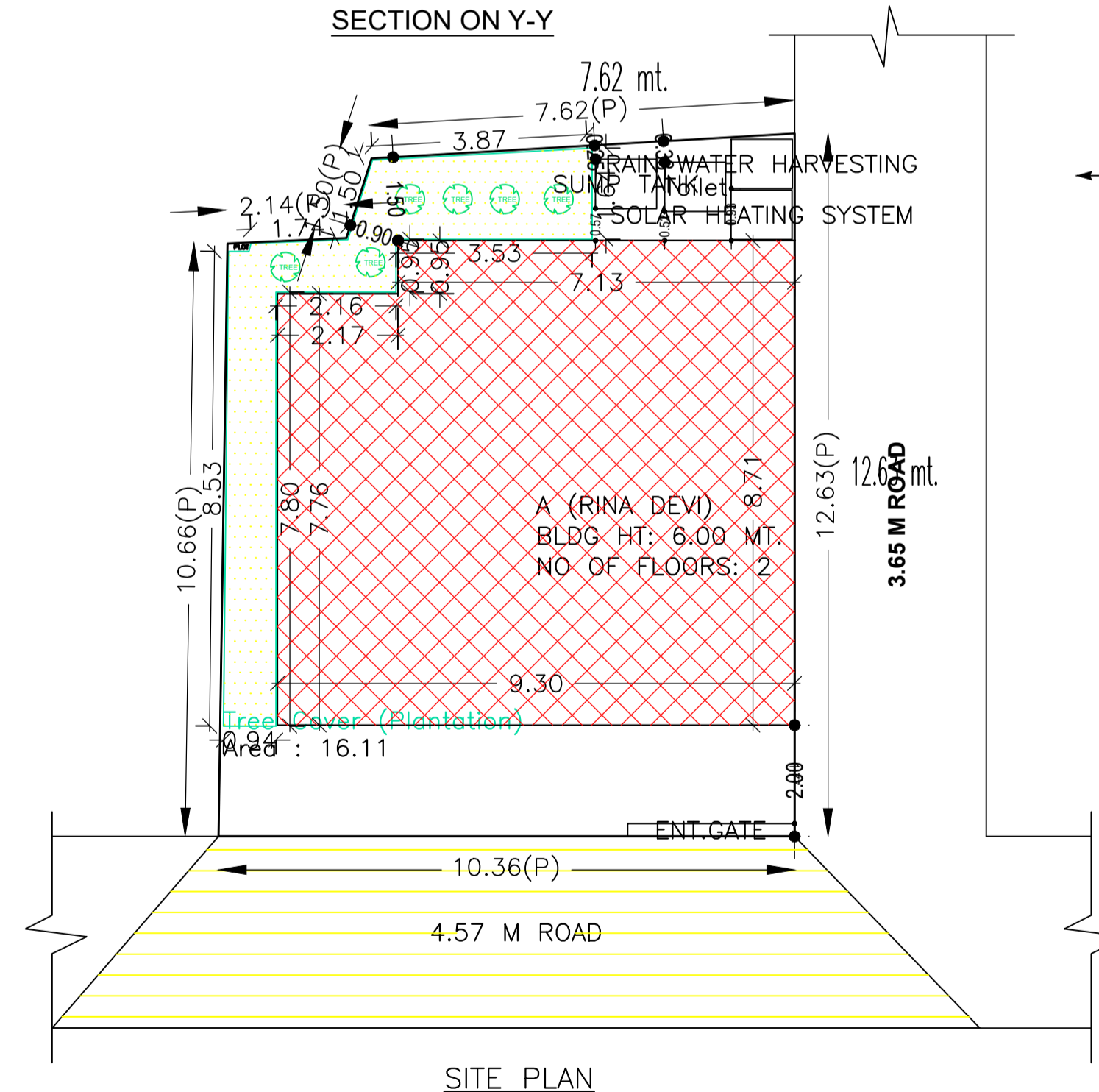
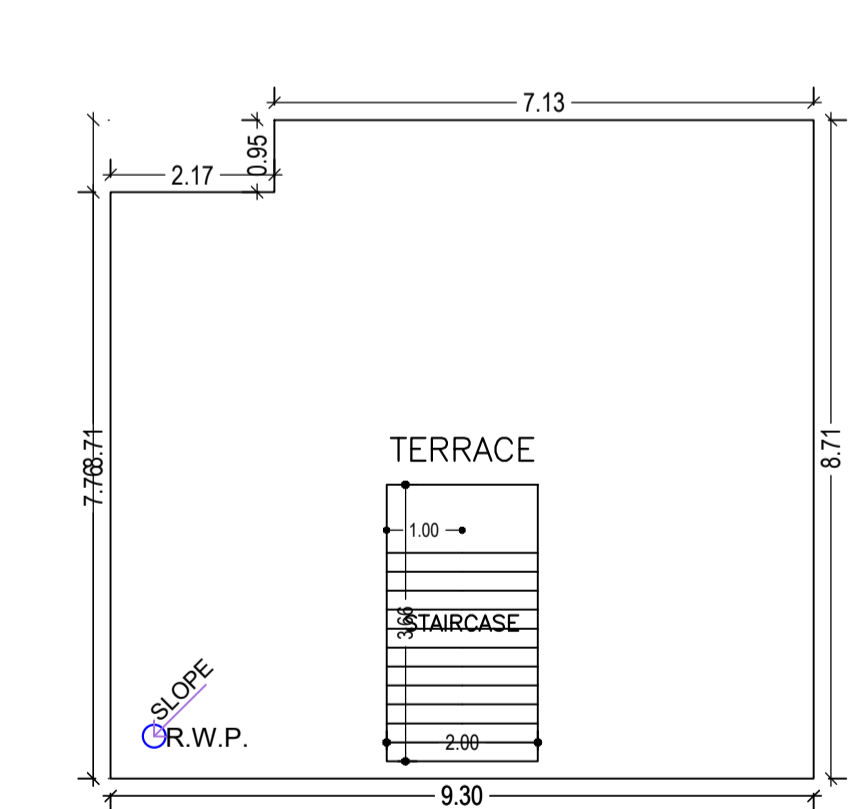
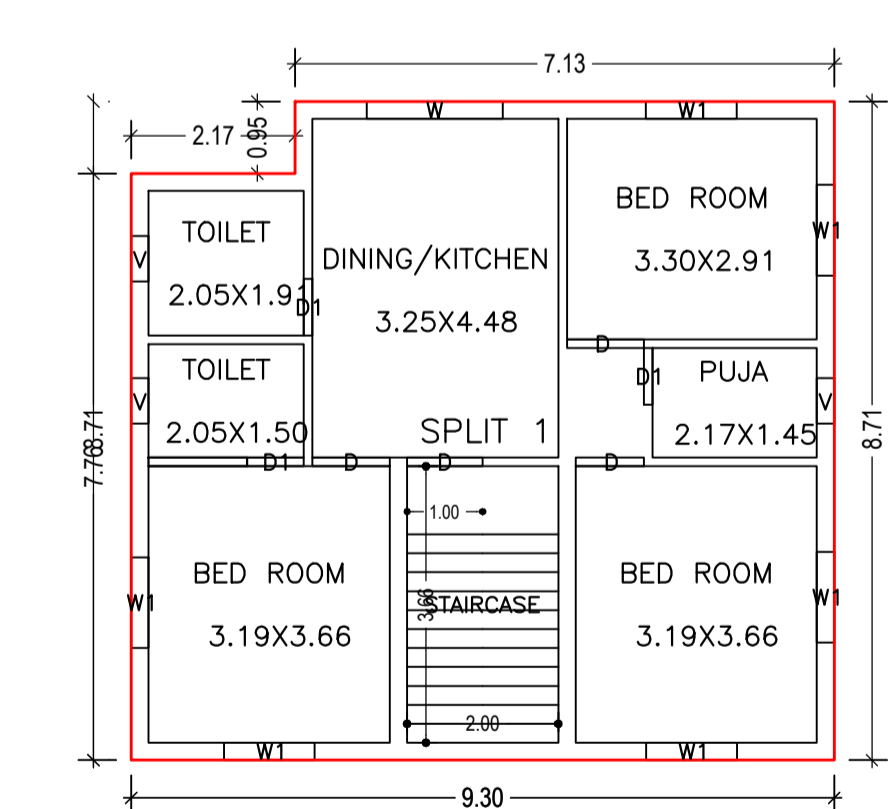
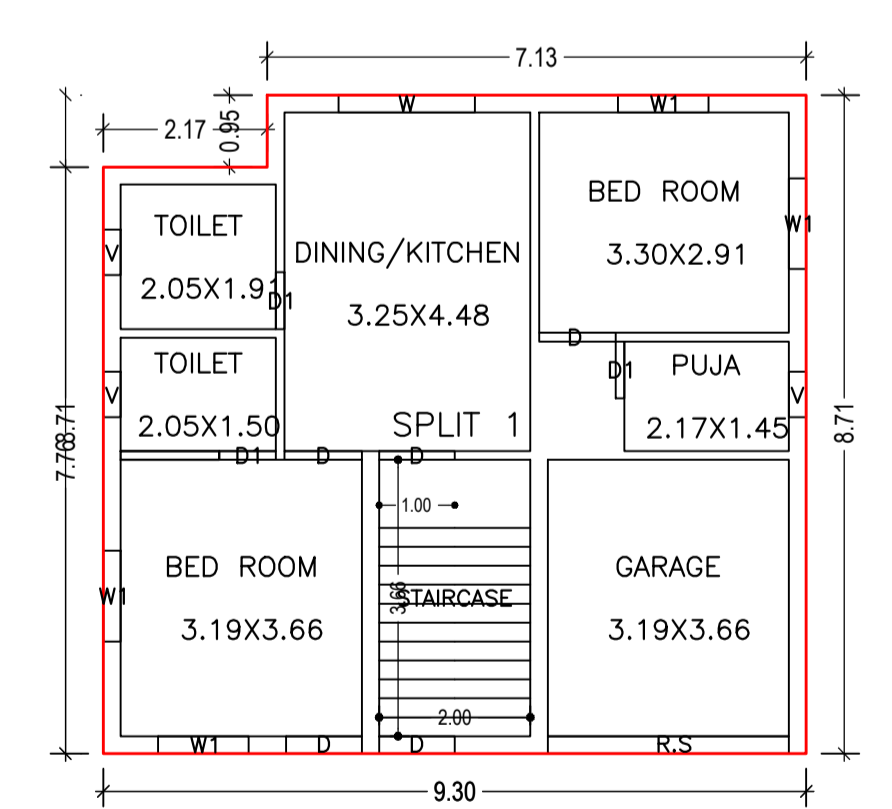
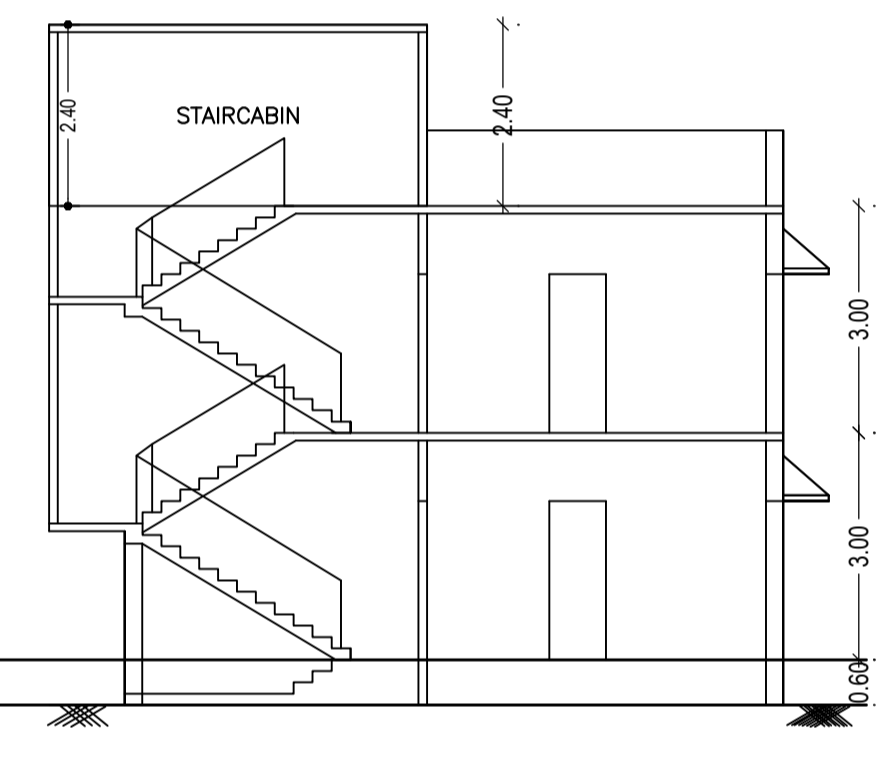
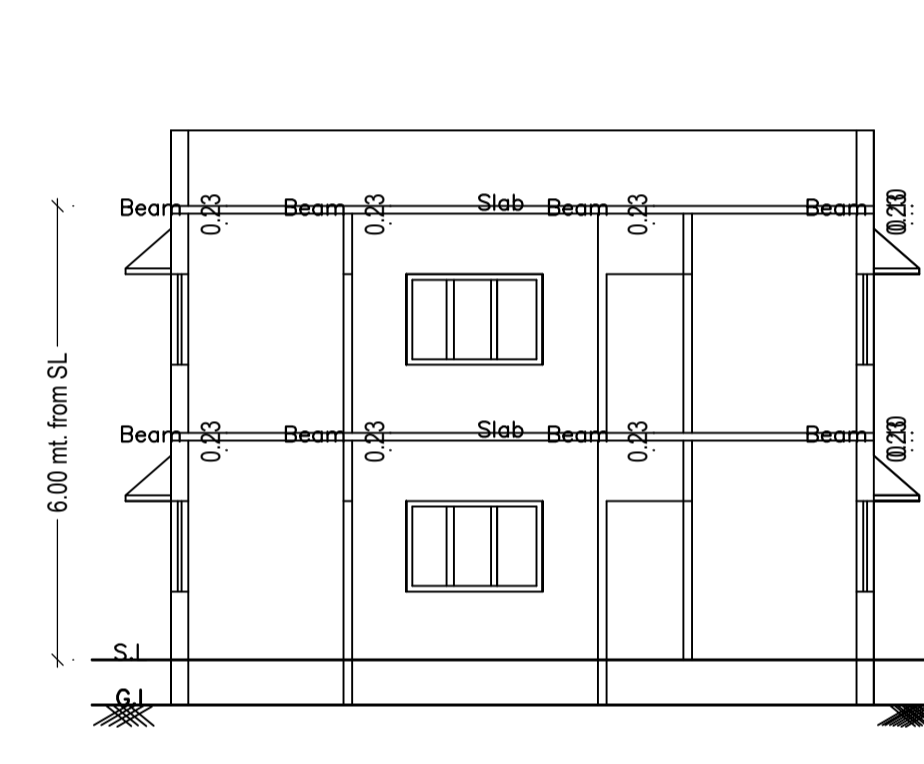
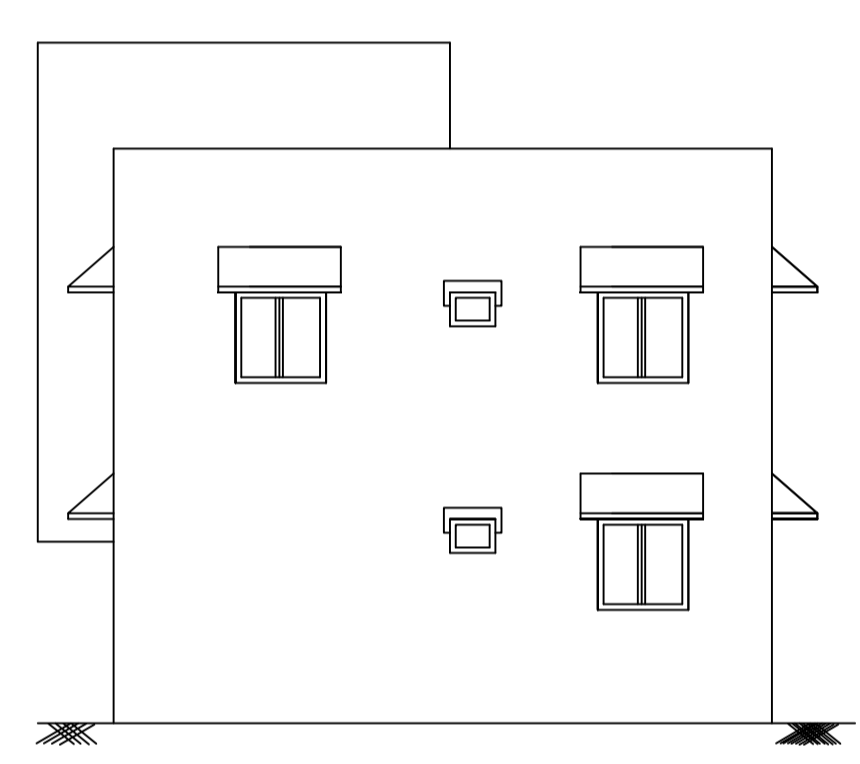
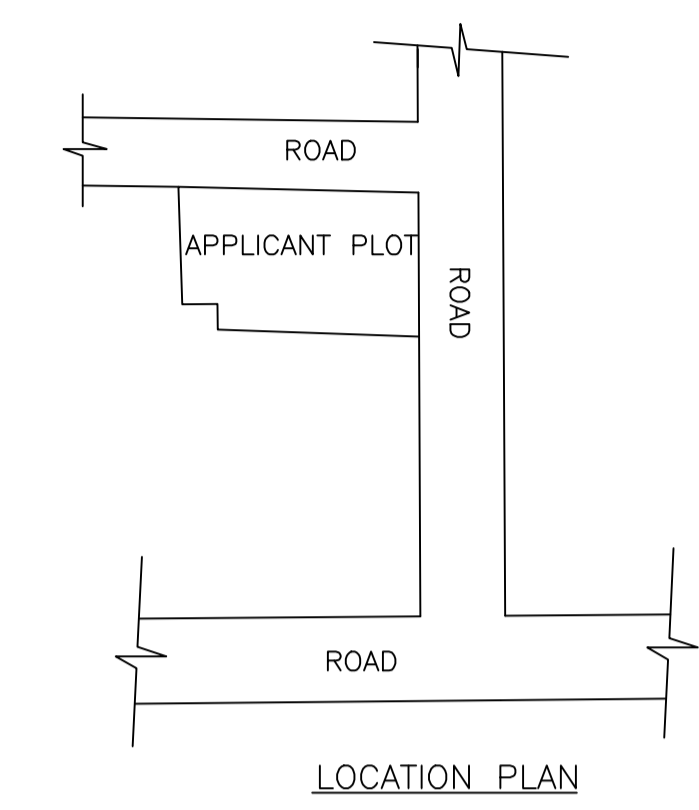
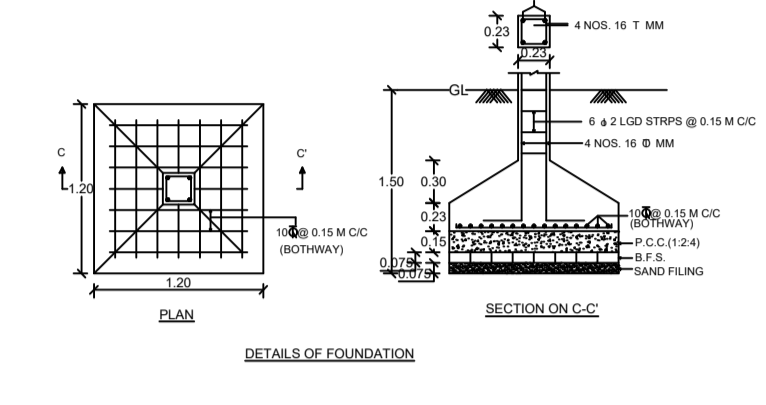
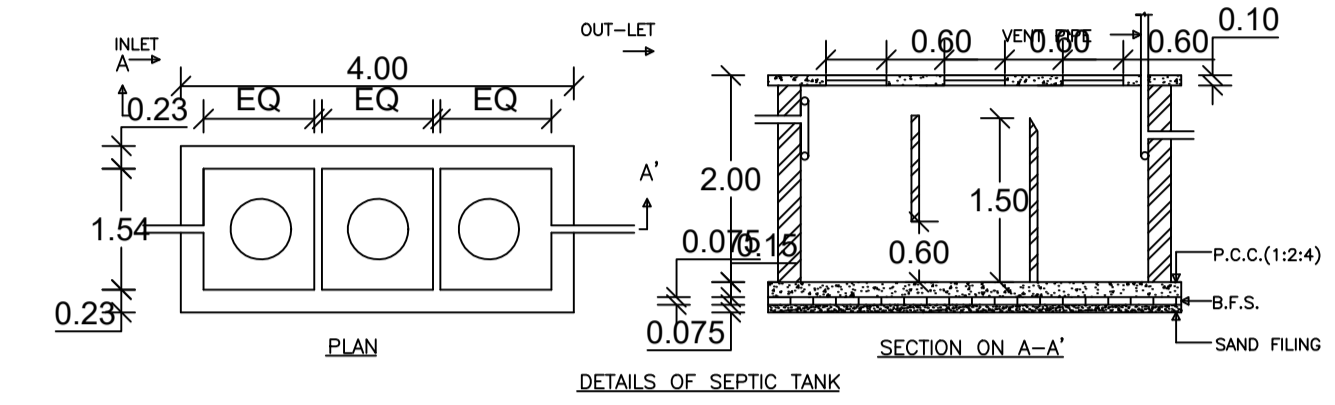
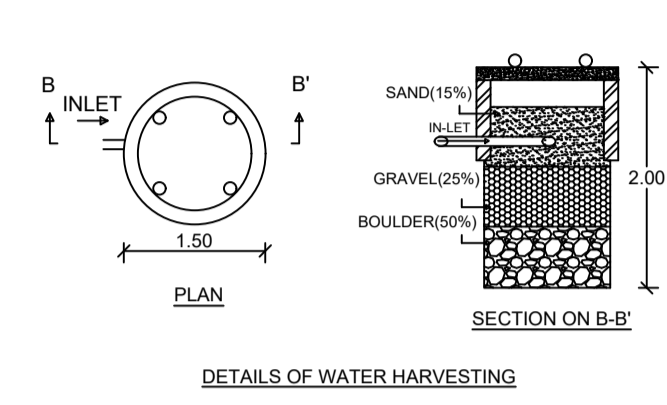
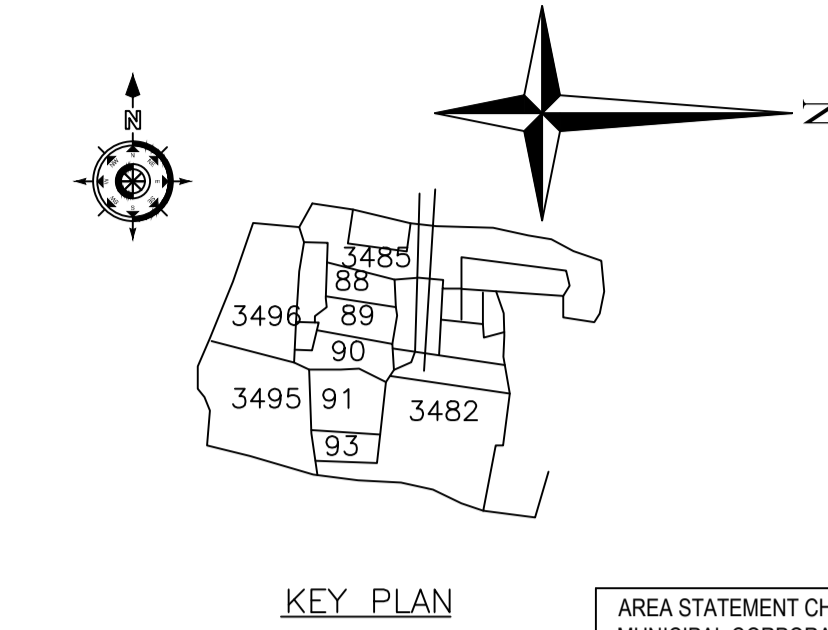

AREA STATEMENT CHAS MUNICIPAL CORPORATION	VERSION NO: 1.0.53	SQ.MT.
PROJECT DETAIL:	VERSION DATE: 16/10/2020	
Region: JHARKHAND URBAN LOCAL BODIES	Plot Use: Residential	
District: BOKARO	Plot SubUse: Bungalow/ Dwelling / Non Apartment	
Authority: CHAS MUNICIPAL CORPORATION	PlotNearbyReligiousStructure: NA	
Inward_No: CMC/BP/0001/W07/2021	PlotSubPlot No: 3485	
Application Type: General Proposal	North: Road Width - 3.65 M ROAD	
Project Type: Building Permission	South: Plot No. - 3488	
Nature of Development: New	East: Road Width - 6.10 M ROAD	
Location of Development Area: Old Area	West: Plot No. - PART OF PLOT	
AREA DETAILS:		
AREA OF PLOT (Minimum)	(A)	123.36
NET AREA OF PLOT(Gross Plot Area - Deduction from Gross Plot area)	(A-Deductions)	123.36
Deduction for Balance Plot Area(from Gross Plot Area)		
Common Plot		16.11
Total		16.11
BALANCE AREA OF PLOT(Net Plot Area - Recreational/Amenity space)	(A-Deductions)	107.25
PLOT AREA FOR COVERAGE(Net Plot Area)	(A-Deductions)	123.36
Plot Area for FAR (Net Plot Area + Road Widening Area)	(A-Deductions)	123.36
COVERAGE CHECK		
Permissible Coverage area (70.00 %)		86.35
Proposed Coverage Area (63.98 %)		78.93
Total Prop. Coverage Area (63.98 %)		78.93
Balance coverage area (6.01 %)		7.42
FAR CHECK		
Perm. FAR Area (1.50)		185.04
Total Perm. FAR area		185.04
Residential FAR		157.86
Proposed FAR Area		157.86
Total Proposed FAR Area		157.86
Consumed FAR (Factor)		1.28
Balance FAR Area		27.18
BUILT UP AREA CHECK		
Total Proposed BuiltUp Area		157.86
ARCHITECT (Regd)		RAVI KUMAR
ENGINEER (Regd)		
SUPERVISOR (Regd)		
OWNER (Regd)		RINA DEVI
DEVELOPMENT AUTHORITY		LOCAL BODY

Building :A (RINA DEVI)					
Floor Name	Total Built Up Area (Sq.mt.)	Proposed FAR Area (Sq.mt.) Resi.	Total FAR Area (Sq.mt.)	Total Consumed Additional FAR Area (Sq.mt.)	Tnmt (No.)
Ground Floor	78.93	78.93	78.93	78.93	01
First Floor	78.93	78.93	78.93	78.93	00
Terrace Floor	0.00	0.00	0.00	0.00	00
Total :	157.86	157.86	157.86	157.86	01
Total Number of Same Buildings :	1				
Total :	157.86	157.86	157.86	157.86	01

Buildingwise Floor FAR Details				
Floor Name	Building Name		Total	
	Proposed Built Up Area (Sq.mt.)	Proposed FAR Area (Sq.mt.)	Total Proposed Built Up Area (Sq.mt.)	Total FAR Area (Sq.mt.)
Ground Floor	78.93	78.93	78.93	78.93
First Floor	78.93	78.93	78.93	78.93
Terrace Floor	0.00	0.00	0.00	0.00
Total :	157.86	157.86	157.86	157.86

COLOR INDEX	
PLOT BOUNDARY	Black
ABUTTING ROAD	Green
PROPOSED CONSTRUCTION	Red
COMMON PLOT	Yellow
ROAD WIDENING AREA	Blue
EXISTING (To be retained)	Blue
EXISTING (To be demolished)	Yellow

SCHEDULE OF DOOR:

BUILDING NAME	NAME	LENGTH	HEIGHT	NOS
A (RINA DEVI)	D1	0.75	2.10	06
A (RINA DEVI)	D	0.90	2.10	01
A (RINA DEVI)	D	1.00	2.10	03
A (RINA DEVI)	D	1.02	2.10	04
A (RINA DEVI)	R.S	3.19	2.10	01

SCHEDULE OF WINDOW/VENTILATION:

BUILDING NAME	NAME	LENGTH	HEIGHT	NOS
A (RINA DEVI)	V	0.60	1.20	06
A (RINA DEVI)	W1	1.20	1.20	10
A (RINA DEVI)	W	1.80	1.20	02

FAR & Tenement Details (Table 4c-1)

Building	No. of Same Bldg	Total Built Up Area (Sq.mt.)	Proposed FAR Area (Sq.mt.) Resi.	Total FAR Area (Sq.mt.)	Total Consumed Additional FAR Area (Sq.mt.)	Tnmt (No.)
A (RINA DEVI)	1	157.86	157.86	157.86	157.86	01
Grand Total :	1	157.86	157.86	157.86	157.86	01

UnitBUA Table for Building :A (RINA DEVI)

FLOOR	Name	UnitBUA Type	UnitBUA Area	Carpet Area	No. of Rooms	No. of Tenement
GROUND FLOOR	SPLIT 1	FLAT	157.86	157.56	7	1
FIRST FLOOR	SPLIT 1	FLAT	0.00	0.00	7	0
Total:	-	-	157.86	157.56	14	1

Building USE/SUBUSE Details

Building Name	Building Use	Building SubUse	Building Structure
A (RINA DEVI)	Residential	Bungalow/ Dwelling / Non Apartment	Non-Highrise

LTP NAME AND SIGNATURE	STRUCTURAL ENG'S NAME AND SIGNATURE	BUILDER NAME AND SIGNATURE	DIGITAL SIGNATURE
RAVI KUMAR CMC/DFTM/0024/2017			