

Proposal Basic Information

Proposal File No.	CMC/BP/0002/W04/2021
Owner Name	SMT. RANJU JHA
Khata No	1
Plot No	1479
Village Name	Chas
Use	Residential
SubUse	Bungalow/ Dwelling / Non Apartment

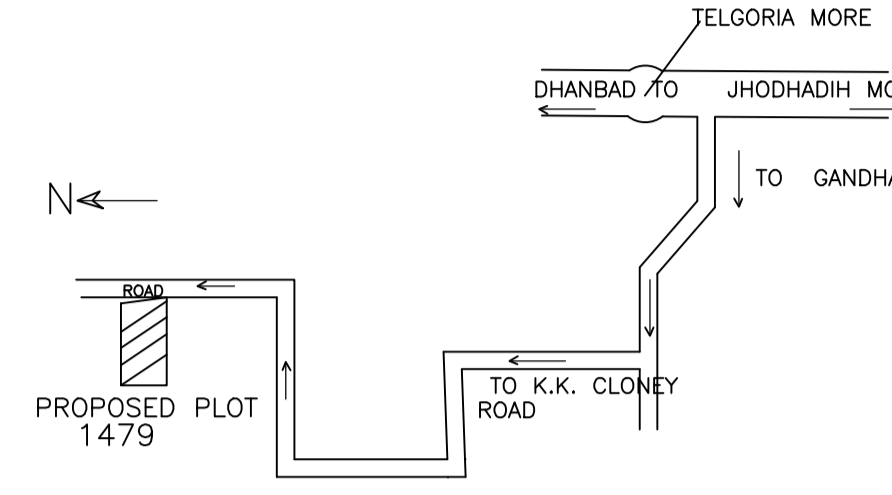

AREA STATEMENT CHAS MUNICIPAL CORPORATION	VERSION NO. : 1.0.54	
PROJECT DETAIL:	VERSION DATE: 16/10/2020	
Region: JHARKHAND URBAN LOCAL BODIES	Plot Use: Residential	
District: BOKARO	Plot SubUse: Bungalow/ Dwelling / Non Apartment	
Authority: CHAS MUNICIPAL CORPORATION	PlotNearbyReligiousStructure: NA	
Inward No: CMC/BP/0002/W04/2021	PlotSubPlot No: 1479	
Application Type: General Proposal	North: CTS No. - BABITA DEVI	
Project Type: Building Permission	South: CTS No. - SMT. SUDHA KANTH	
Nature of Development: New	East: Road Width - 6.1	
Location of Development Area: Old Area	West: CTS No. - KAMTA PRASAD RAI DEEGAR	
AREA DETAILS:		SQ. MT.
AREA OF PLOT (Minimum)	(A)	248.52
NET AREA OF PLOT(Gross Plot Area - Deduction from Gross Plot area)	(A-Deductions)	248.52
Deduction for Balance Plot Area(from Gross Plot Area)		
Common Plot		42.88
Total		42.88
BALANCE AREA OF PLOT(Net Plot Area - Recreational/Amenity space)	(A-Deductions)	205.64
PLOT AREA FOR COVERAGE(Net Plot Area)	(A-Deductions)	248.52
Plot Area for FAR (Net Plot Area + Road Widening Area)	(A-Deductions)	248.52
COVERAGE CHECK		
Permissible Coverage area (60.00 %)		149.11
Proposed Coverage Area (59.97 %)		149.04
Total Prop. Coverage Area (59.97 %)		149.04
Balance coverage area (0.03 %)		0.07
FAR CHECK		
Perm. FAR Area (2.50)		621.30
Total Perm. FAR area		621.30
Residential FAR		297.05
Proposed FAR Area		297.05
Total Proposed FAR Area		297.05
Consumed FAR (Factor)		1.20
Balance FAR Area		324.25
BUILT UP AREA CHECK		
Total Proposed BuiltUp Area		300.27
ARCHITECT (Regd)		SUBHASH NARHARRAO NETRAGAONKAR
ENGINEER (Regd)		
SUPERVISOR (Regd)		
OWNER (Regd)		SMT. RANJU JHA
DEVELOPMENT AUTHORITY		LOCAL BODY

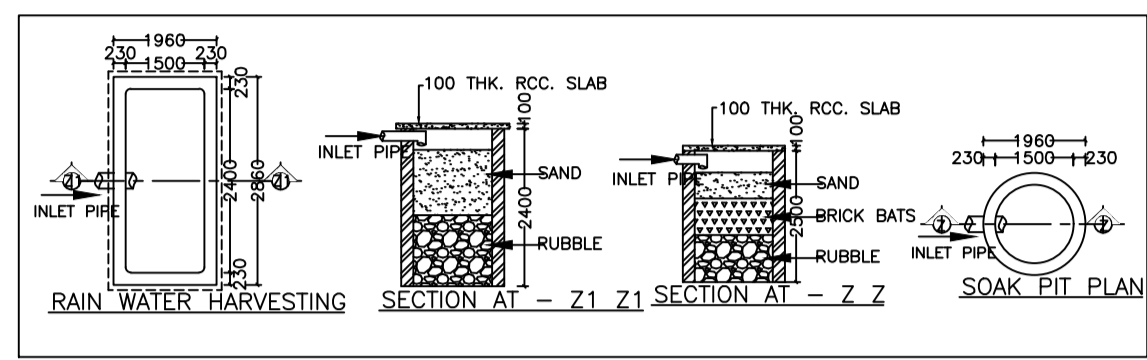
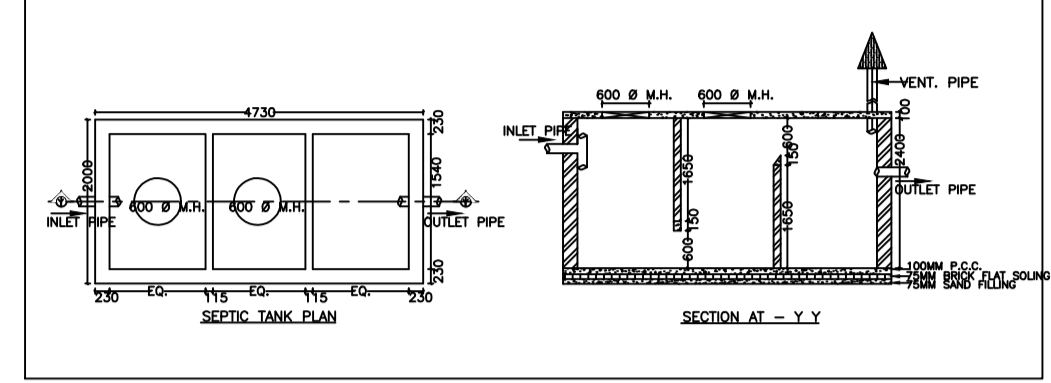
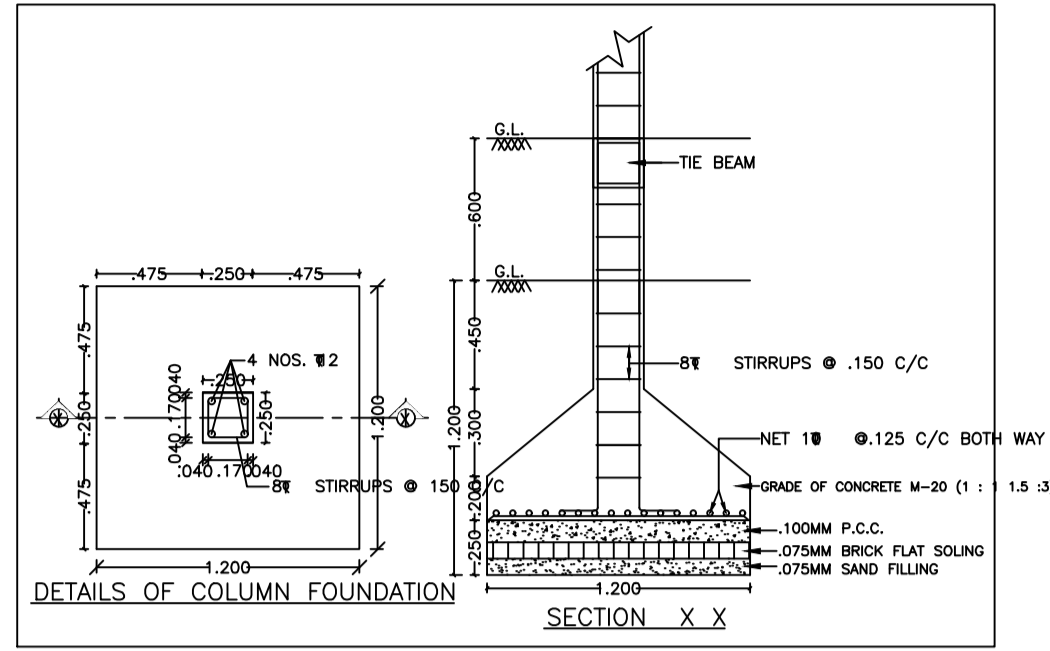
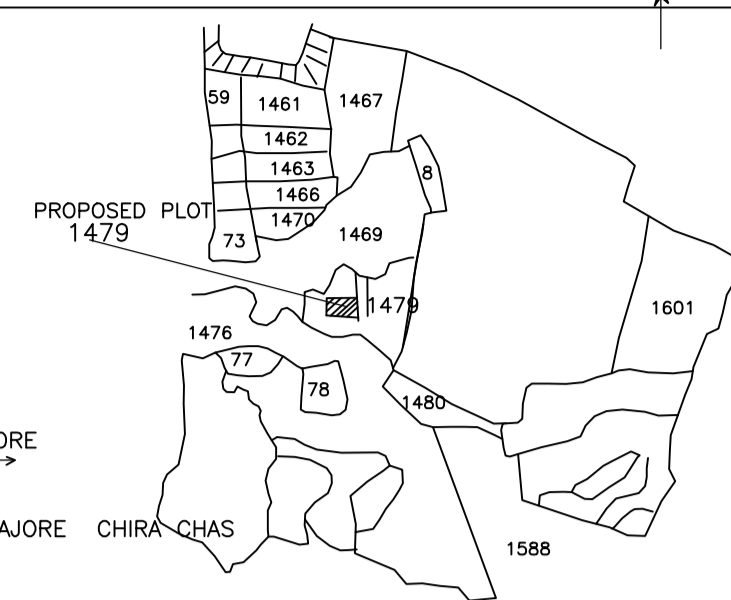
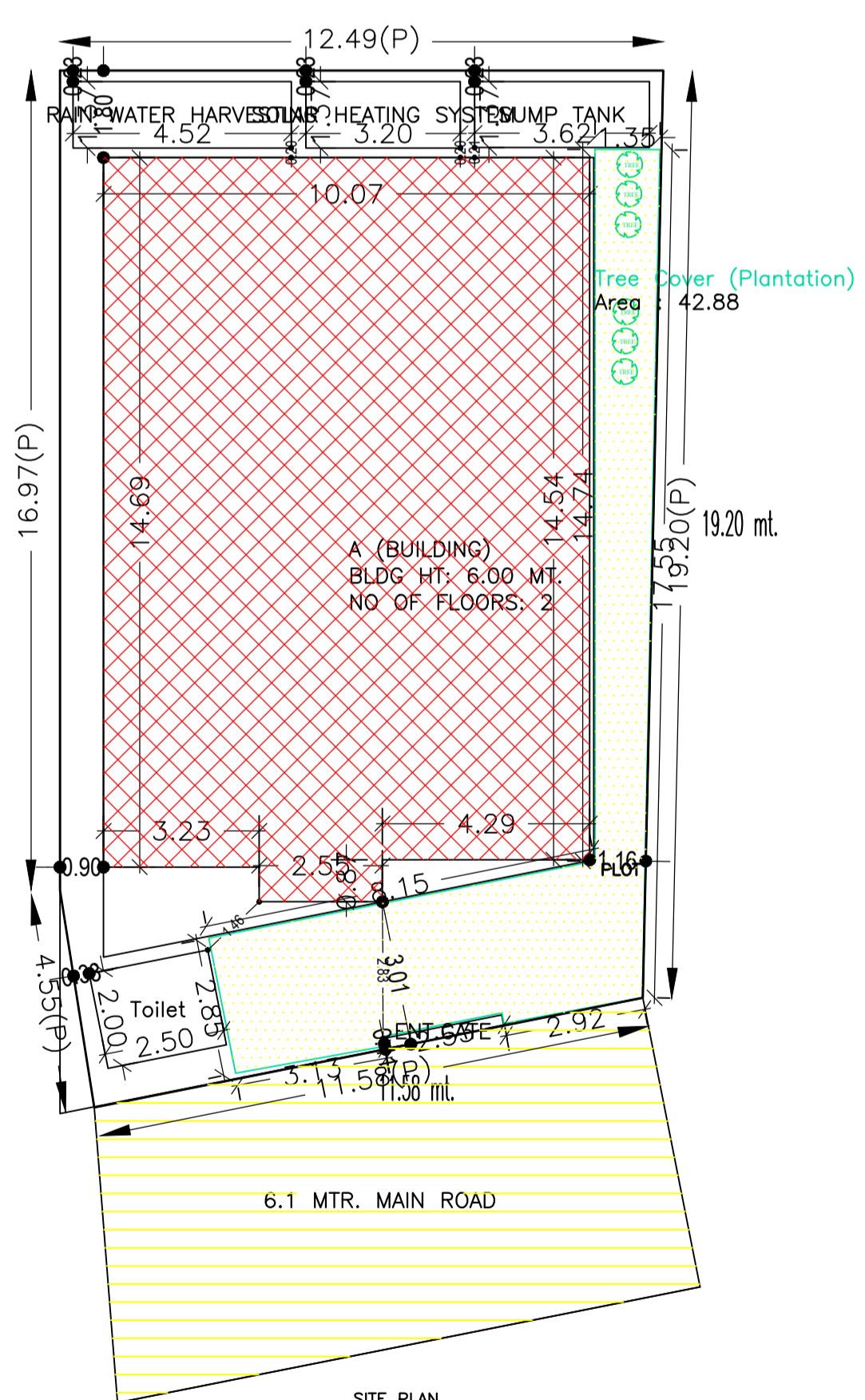
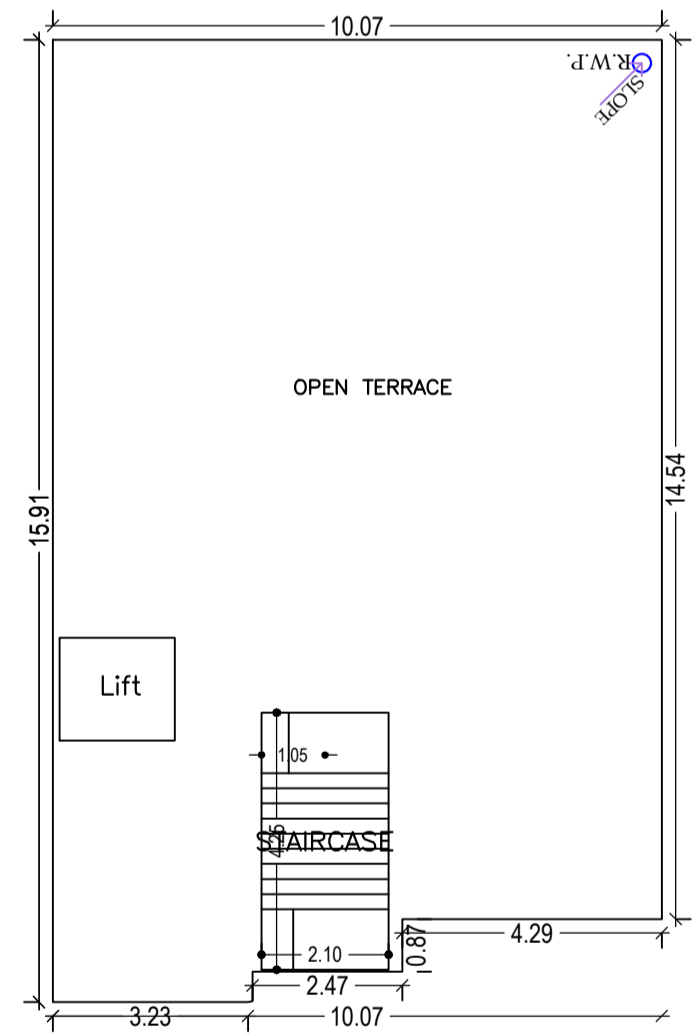
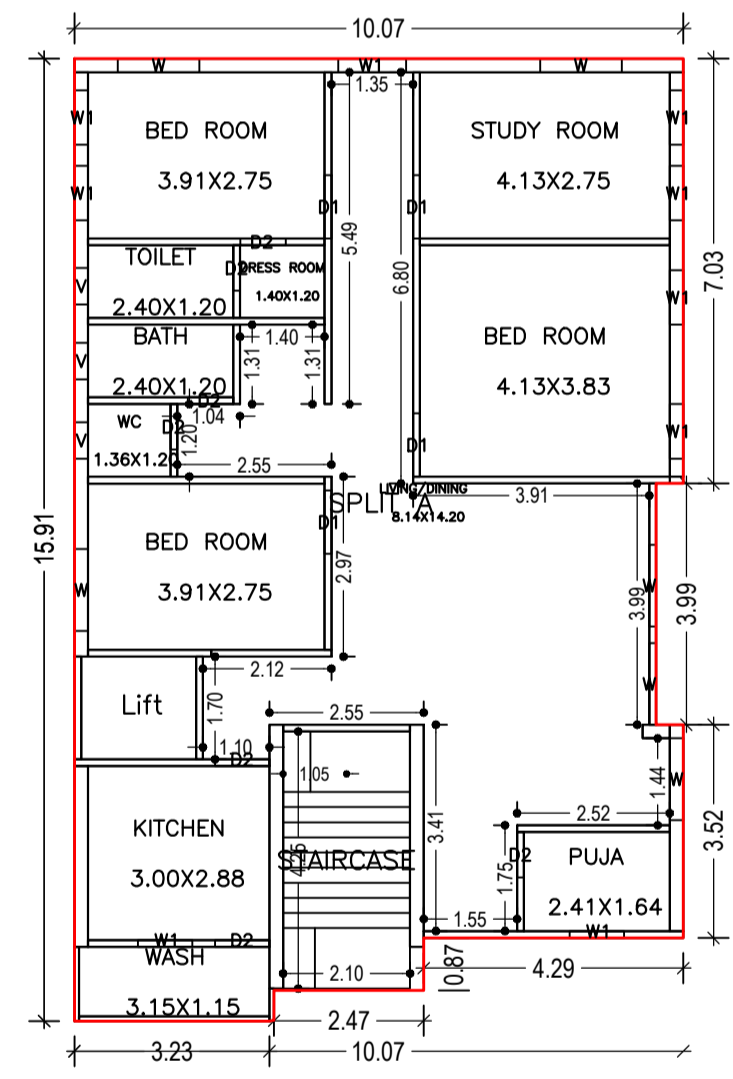
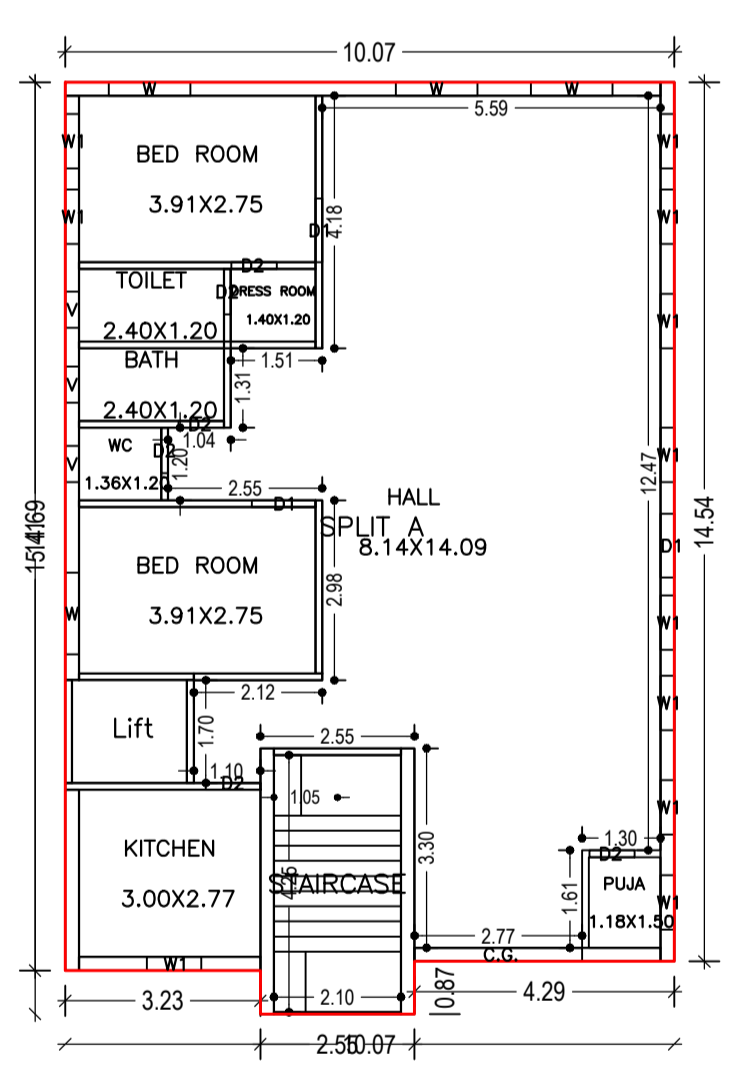
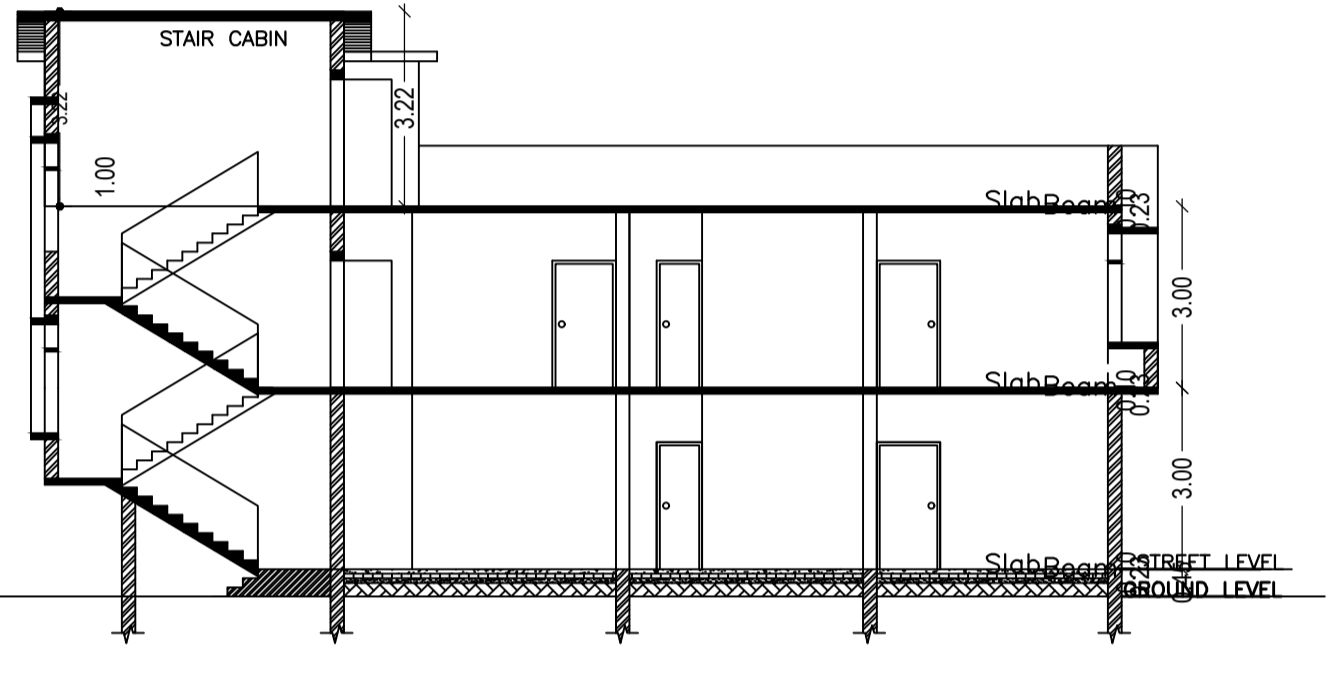
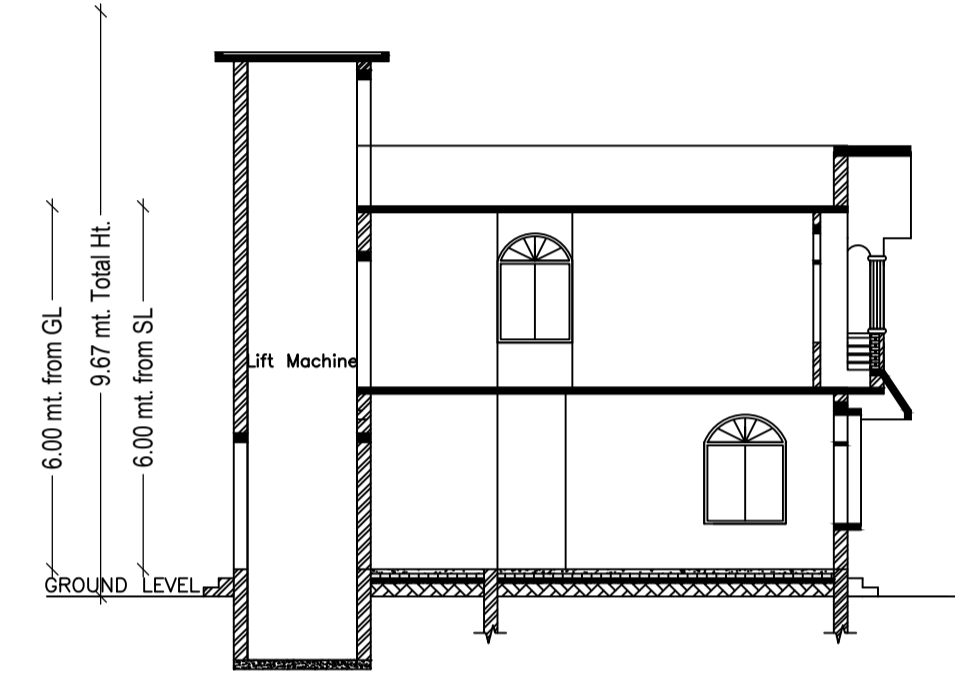
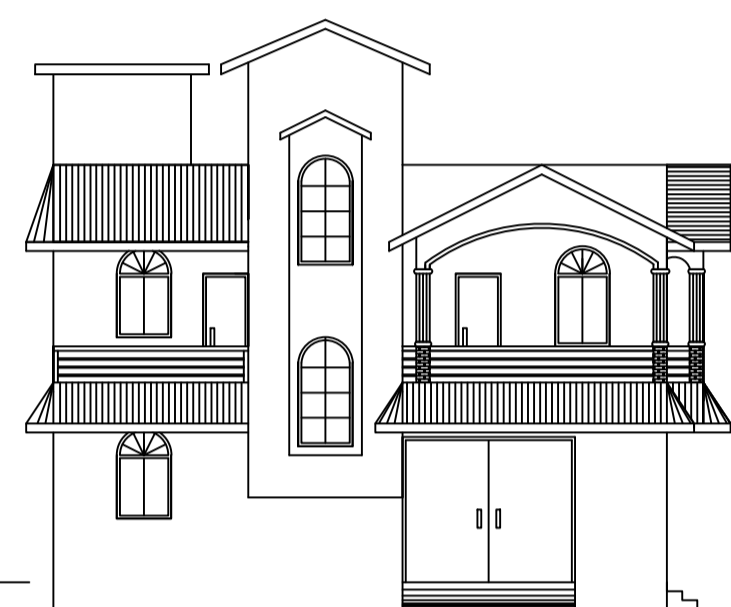

Building :A (BUILDING)

Floor Name	Total Built Up Area (Sq.mt.)	Deductions (Area in Sq.mt.)	Proposed FAR Area (Sq.mt.)	Total FAR Area (Sq.mt.)	Total Consumed Additional FAR Area (Sq.mt.)	Tnmt (No.)
Ground Floor	149.04	0.00	149.04	149.04	149.04	01
First Floor	151.23	3.23	148.00	148.00	148.00	00
Terrace Floor	0.00	0.00	0.00	0.00	0.00	00
Total :	300.27	3.23	297.04	297.04	297.04	01
Total Number of Same Buildings	1					
Total :	300.27	3.23	297.04	297.04	297.04	01

Buildingwise Floor FAR Details

Floor Name	Building Name A (BUILDING)		Total	
	Proposed Built Up Area (Sq.mt.)	Proposed FAR Area (Sq.mt.)	Total Proposed Built Up Area (Sq.mt.)	Total FAR Area (Sq.mt.)
Ground Floor	149.04	149.04	149.04	149.04
First Floor	151.23	148.00	151.23	148.00
Terrace Floor	0.00	0.00	0.00	0.00
Total :	300.27	297.04	300.27	297.04

COLOR INDEX

PLOT BOUNDARY	Black
ABUTTING ROAD	Green
PROPOSED CONSTRUCTION	Red
COMMON PLOT	Yellow
ROAD WIDENING AREA	Blue
EXISTING (To be retained)	Light Blue
EXISTING (To be demolished)	White

SCHEDULE OF DOOR:

BUILDING NAME	NAME	LENGTH	HEIGHT	NOS
A (BUILDING)	D2	0.75	2.10	10
A (BUILDING)	D2	0.90	2.10	03
A (BUILDING)	D1	1.05	2.10	07
A (BUILDING)	C.G.	2.77	2.45	01

SCHEDULE OF WINDOW/VENTILATION:

BUILDING NAME	NAME	LENGTH	HEIGHT	NOS
A (BUILDING)	V	0.60	0.60	06
A (BUILDING)	W1	0.90	1.20	19
A (BUILDING)	W1	1.13	1.20	01
A (BUILDING)	W	1.35	1.20	10

UnitBUA Table for Building :A (BUILDING)

FLOOR	Name	UnitBUA Type	UnitBUA Area	Carpet Area	No. of Rooms	No. of Tenement
GROUND FLOOR PLAN	SPLIT A	FLAT	250.99	242.73	9	1
FIRST FLOOR PLAN	SPLIT A	FLAT	0.00	0.00	12	0
Total:	-	-	250.99	242.73	21	1

Building USE/SUBUSE Details

Building Name	Building Use	Building SubUse	Building Structure
A (BUILDING)	Residential	Bungalow/ Dwelling / Non Apartment	Non-Highrise

FAR & Tenement Details (Table 4c-1)

Building	No. of Same Bldg	Total Built Up Area (Sq.mt.)	Deductions (Area in Sq.mt.)	Proposed FAR Area (Sq.mt.)	Total FAR Area (Sq.mt.)	Total Consumed Additional FAR Area (Sq.mt.)	Tnmt (No.)
A (BUILDING)	1	300.27	3.23	297.04	297.04	297.04	01
Grand Total :	1	300.27	3.23	297.04	297.04	297.04	01

LTP NAME AND SIGNATURE	STRUCTURAL ENG'S NAME AND SIGNATURE	BUILDER NAME AND SIGNATURE	DIGITAL SIGNATURE
SUBHASH NARHARRAO NETRAGAONKAR CMC/ARC/0014/2018			