

Project Title : sk devil

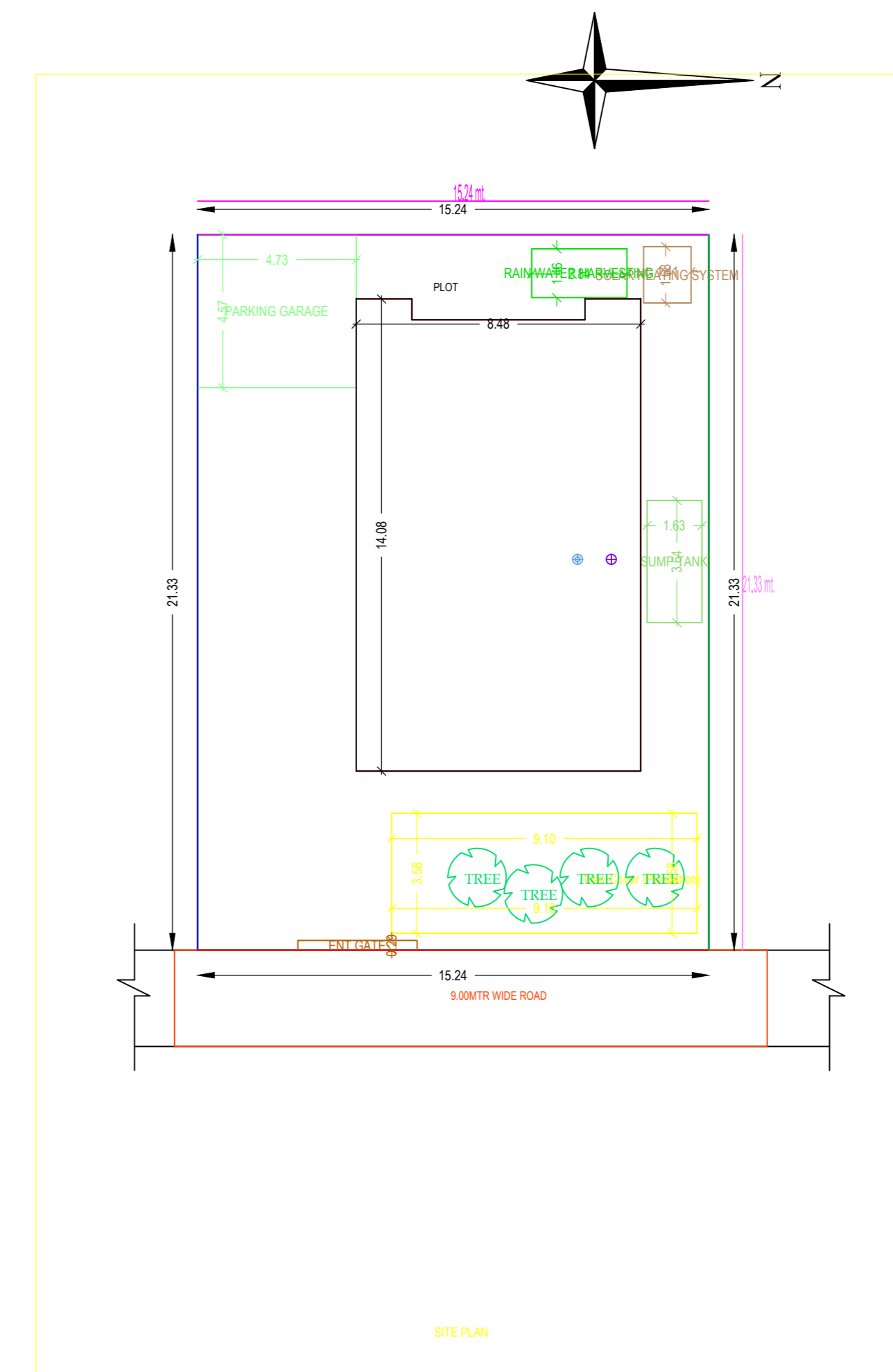
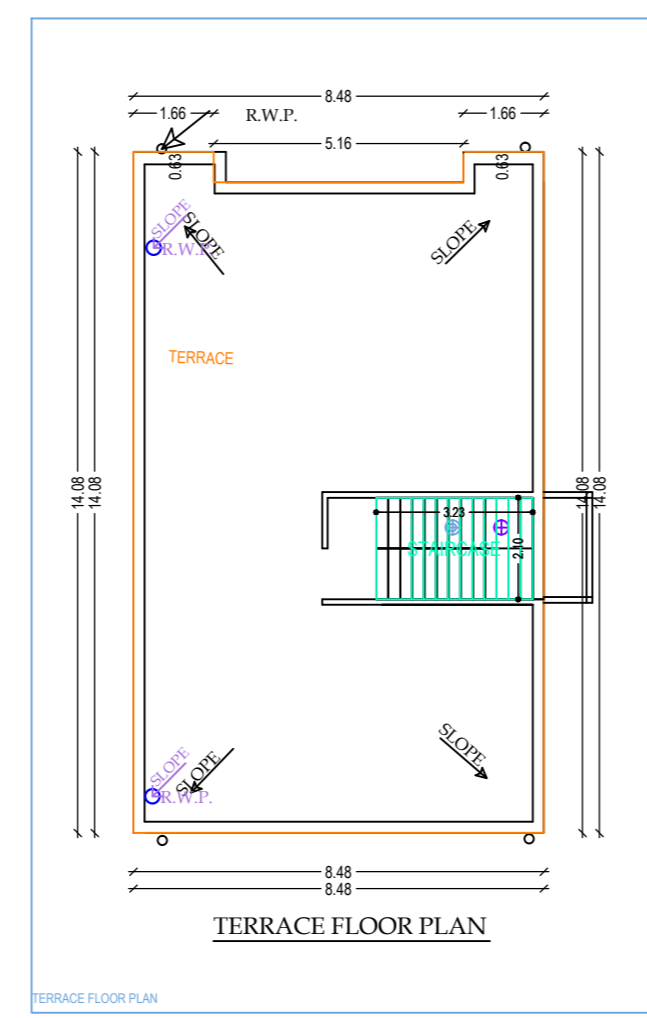
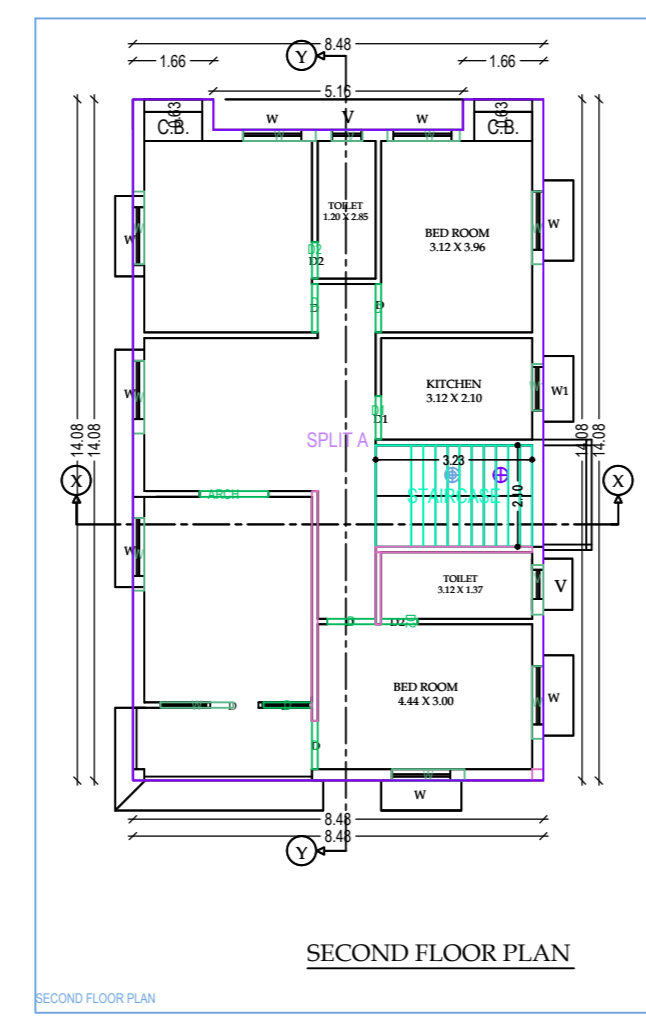
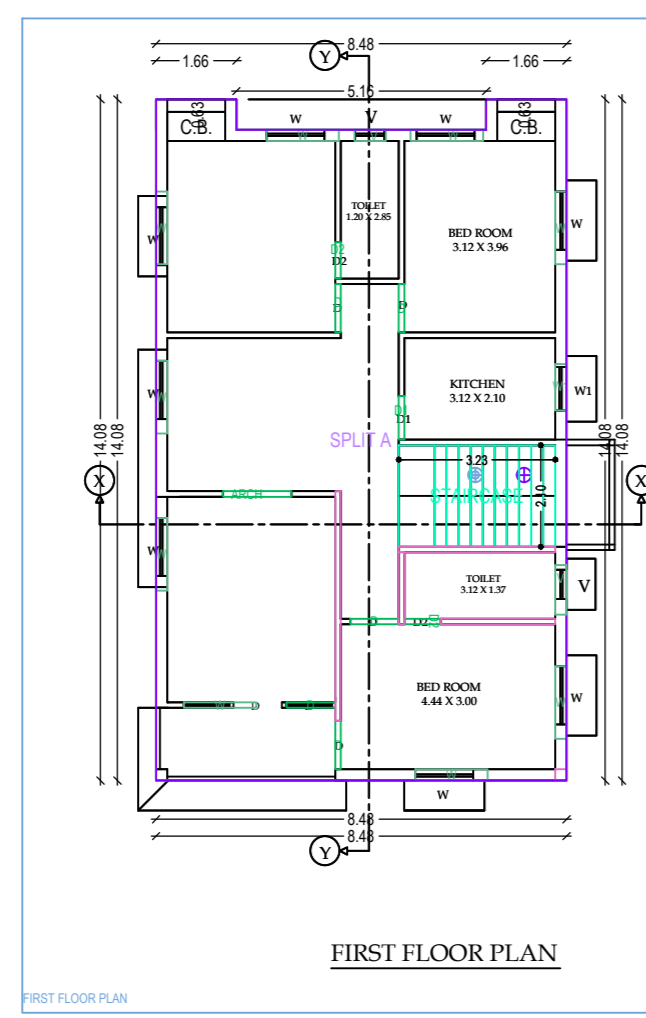
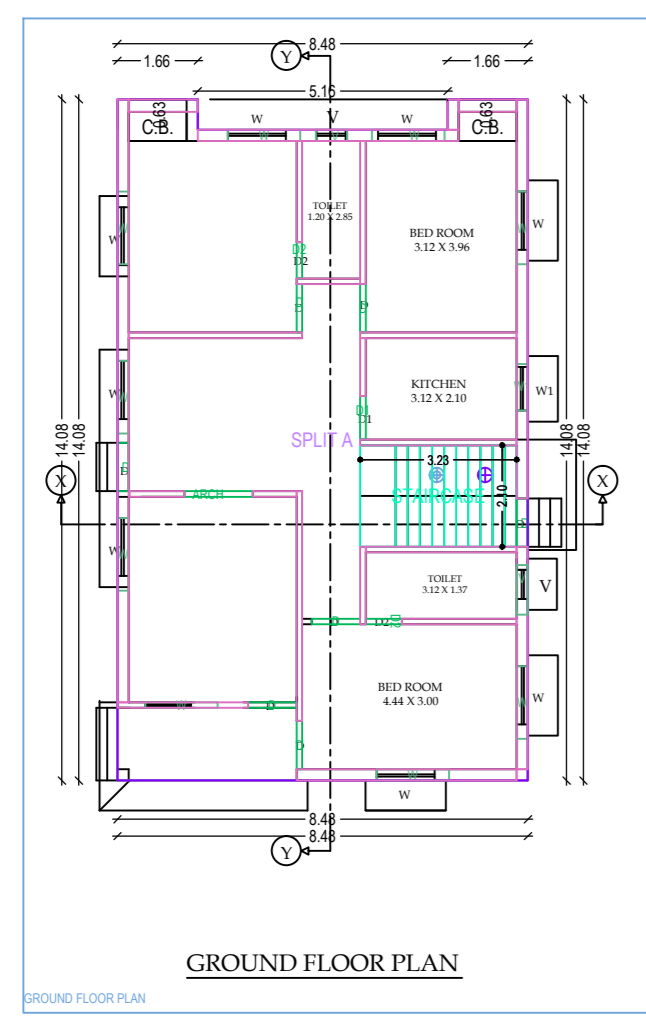
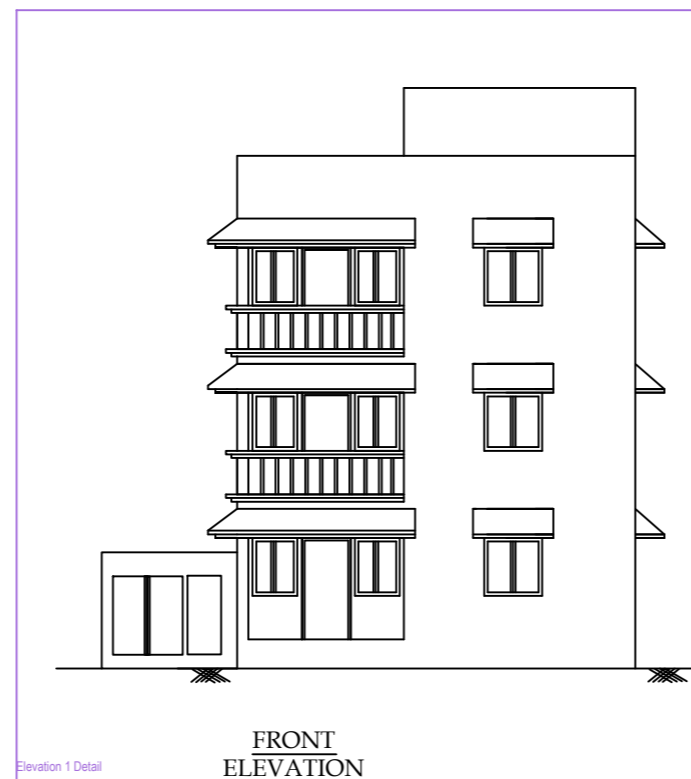
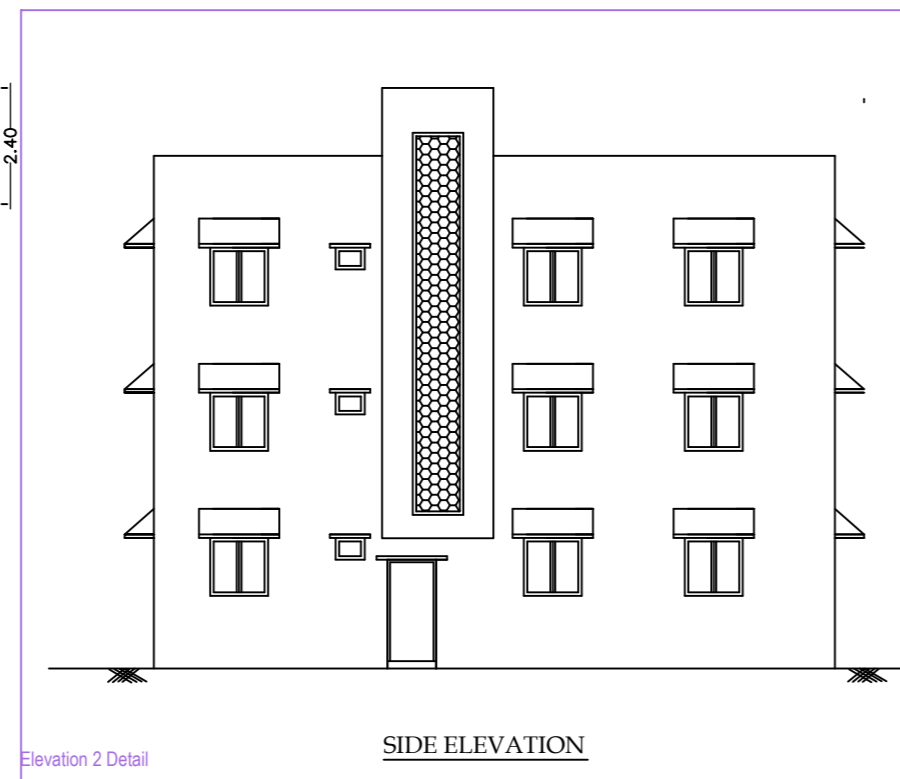
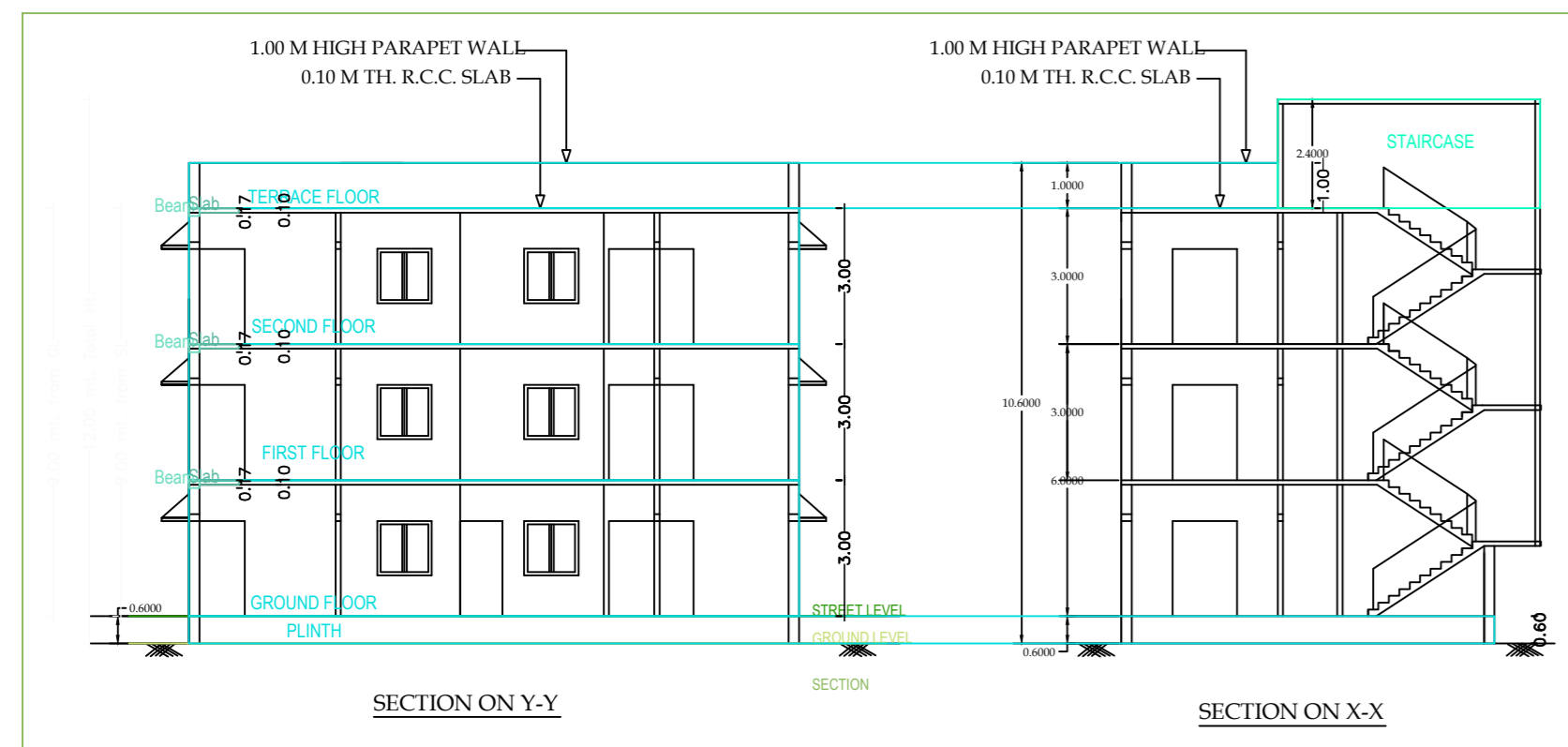
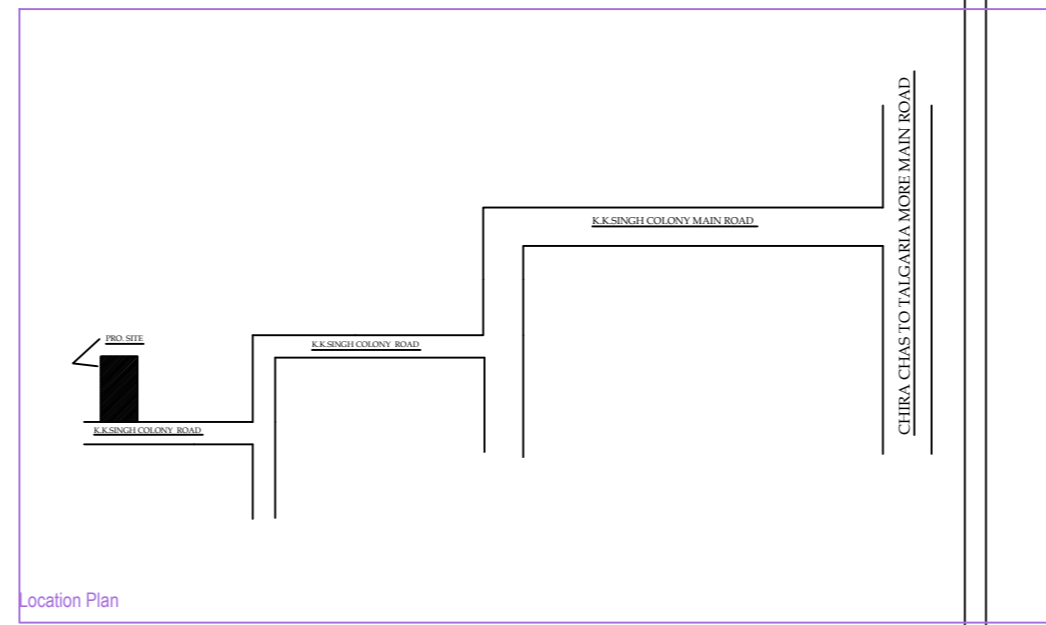
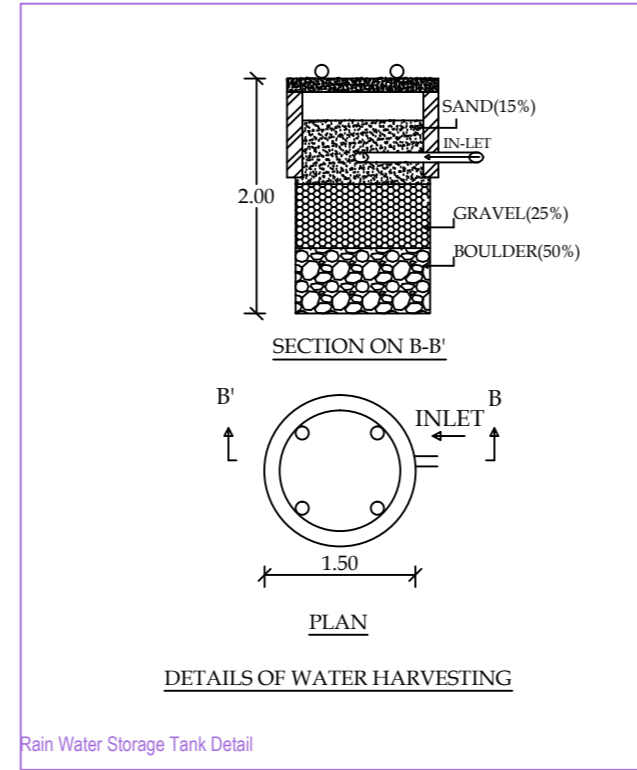
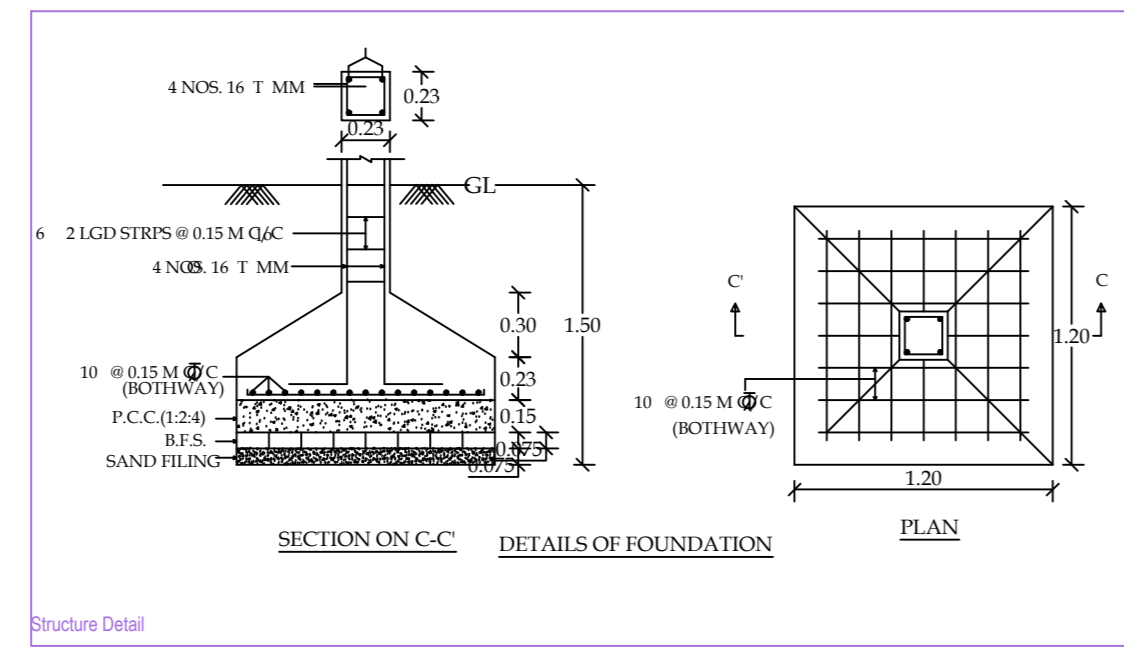
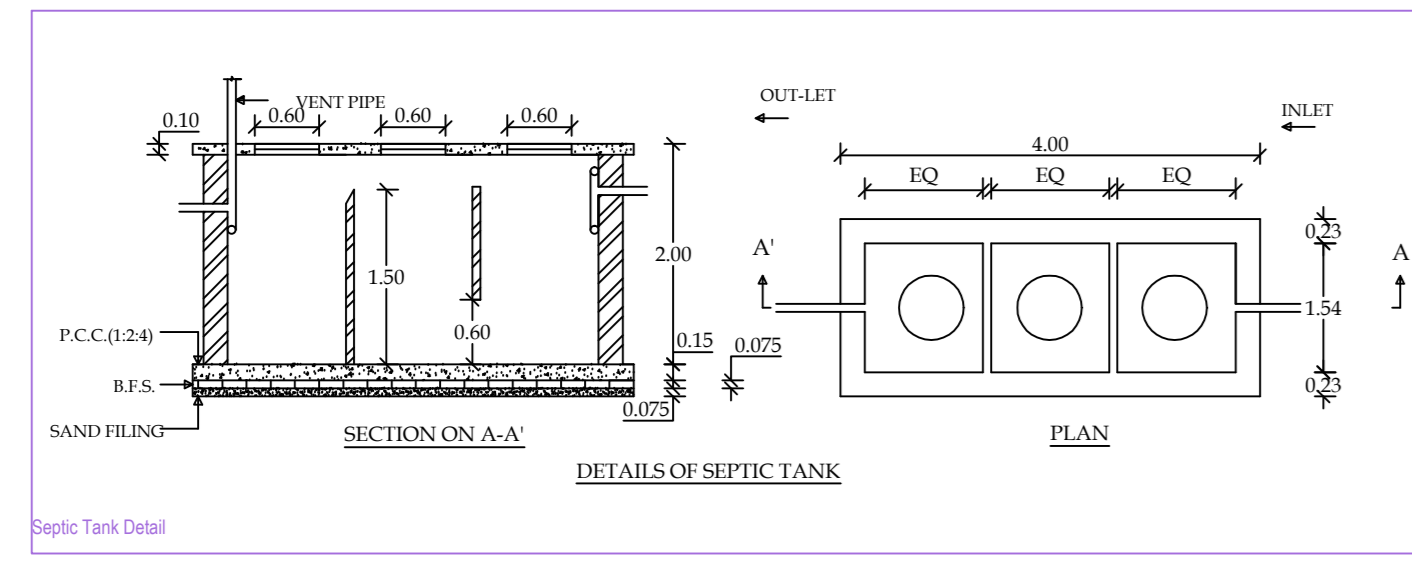

BRIEF STATEMENT OF WORKS		DATE: 10/10/2024
PROJECT NAME:	SK DEVIL	
CLIENT:	SK DEVIL	
LOCATION:	SK DEVIL	
DESIGNER:	SK DEVIL	
DATE:	10/10/2024	
SCALE:	AS SHOWN	
PROJECT NO.:	SK DEVIL	
REVISIONS:		
NO.	DESCRIPTION	DATE
1	ISSUED FOR PERMIT	10/10/2024
2	ISSUED FOR CONSTRUCTION	10/10/2024
3	ISSUED FOR OCCUPANCY	10/10/2024
4	ISSUED FOR AS-BUILT	10/10/2024

COLOR INDEX	
RED	FOUNDATION
GREEN	CONCRETE
BLUE	STEEL
YELLOW	GLASS

BILL OF MATERIALS (Table 40-1)				
Item No.	Description	Quantity	Unit	Remarks
1	Concrete	100.00	m ³	
2	Steel	50.00	kg	
3	Brick	10000.00	nos	
4	Sand	50.00	m ³	
5	Gravel	50.00	m ³	
6	Aggregate	50.00	m ³	
7	Paint	10.00	kg	
8	Plaster	100.00	m ²	
9	Tile	1000.00	nos	
10	Window	10.00	nos	
11	Door	10.00	nos	
12	Staircase	10.00	nos	
13	Roofing	100.00	m ²	
14	Waterproofing	100.00	m ²	
15	Sanitary	10.00	nos	
16	Electrical	10.00	nos	
17	Plumbing	10.00	nos	
18	Painting	10.00	nos	
19	Finishing	10.00	nos	
20	Other	10.00	nos	