

Proposal Basic Information	
Proposal File No.	CMC/BP/0007/W02/2021
Owner Name	LALPAT ROY
Khata No	269
Plot No	1215
Village Name	Chas
Use	Residential
SubUse	Bungalow/ Dwelling / Non Apartment

AREA STATEMENT CHAS MUNICIPAL CORPORATION		VERSION NO. : 1.0.53
PROJECT DETAIL:		VERSION DATE: 16/10/2020
Region - JHARKHAND URBAN LOCAL BODIES	Plot Use: Residential	
District: BOKARO	Plot SubUse: Bungalow/ Dwelling / Non Apartment	
Authority: CHAS MUNICIPAL CORPORATION	PlotNearbyReligiousStructure: NA	
Inward No: CMC/BP/0007/W02/2021	PlotSubPlot No: 1215	
Application Type: General Proposal	North: CTS No. - ASMAL KHAS LAND	
Project Type: Building Permission	South: Road Width - SURVEY ROAD	
Nature of Development: New	East: CTS No. - B/7/B MARK LAND	
Location of Development Area: Old Area	West: CTS No. - ROAD OWN AJMAL KHAS	
AREA DETAILS:		
AREA OF PLOT (Minimum)	(A)	114.95
NET AREA OF PLOT(Gross Plot Area - Deduction from Gross Plot area)	(A-Deductions)	114.95
Deduction for Balance Plot Area(from Gross Plot Area)		
Common Plot		7.53
Total		7.53
BALANCE AREA OF PLOT(Net Plot Area - Recreational/Amenity space)	(A-Deductions)	107.42
PLOT AREA FOR COVERAGE(Net Plot Area)	(A-Deductions)	114.95
Plot Area for FAR (Net Plot Area + Road/Widening Area)	(A-Deductions)	114.95
COVERAGE CHECK		
Permissible Coverage area (70.00 %)		80.46
Proposed Coverage Area (60.44 %)		69.48
Total Prop. Coverage Area (60.44 %)		69.48
Balance coverage area (9.55 %)		10.98
FAR CHECK		
Perm. FAR Area ( 2.50 )		287.38
Total Perm. FAR area		287.38
Residential FAR		138.09
Proposed FAR Area		138.09
Total Proposed FAR Area		138.09
Consumed FAR (Factor)		1.20
Balance FAR Area		149.29
BUILT UP AREA CHECK		
Total Proposed BuiltUp Area		138.09
ARCHITECT (Regd)		AMRIT KUMAR MAHATO
ENGINEER (Regd)		
SUPERVISOR (Regd)		
OWNER (Regd)		LALPAT ROY
DEVELOPMENT AUTHORITY		LOCAL BODY

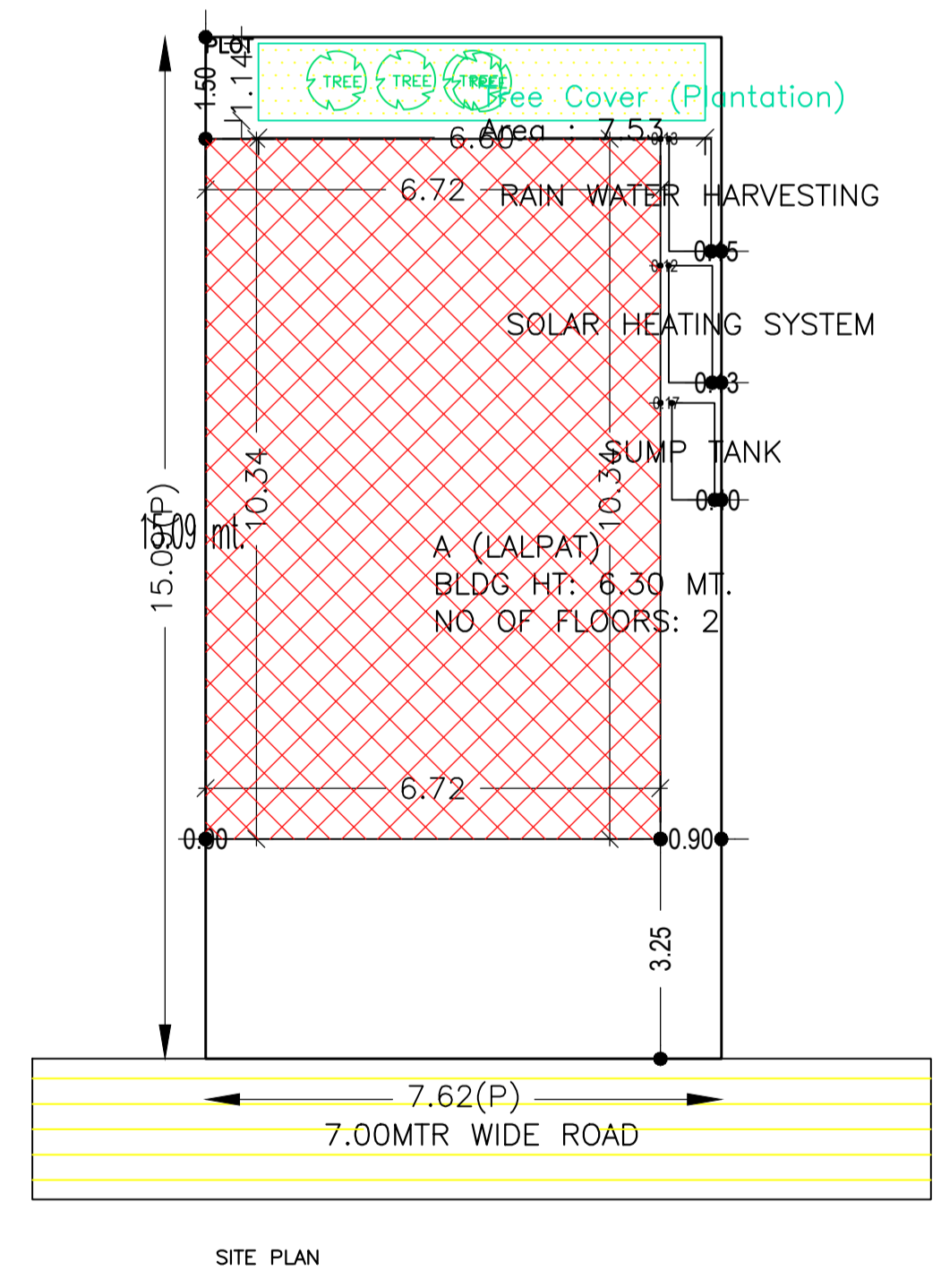
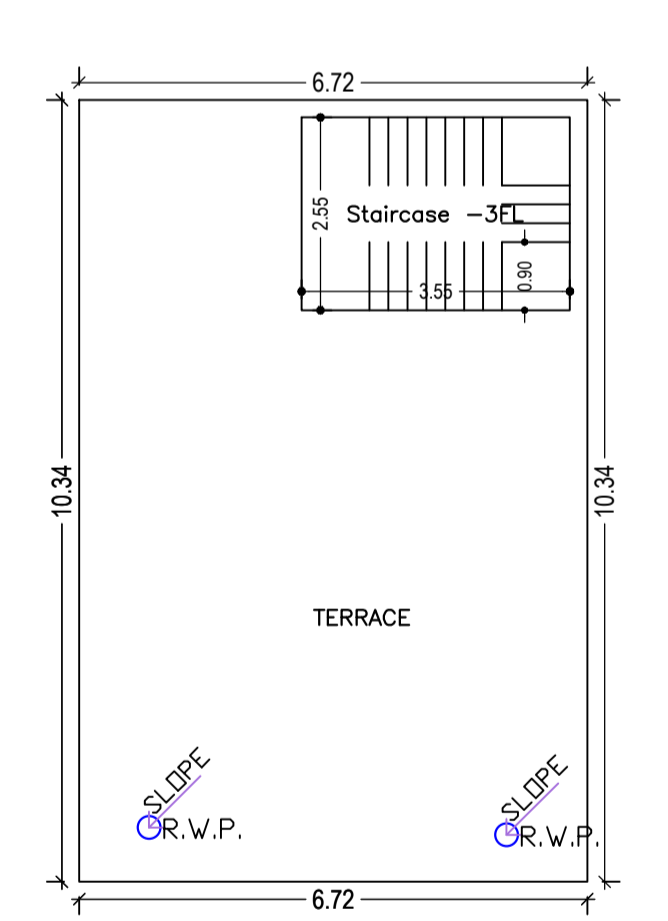
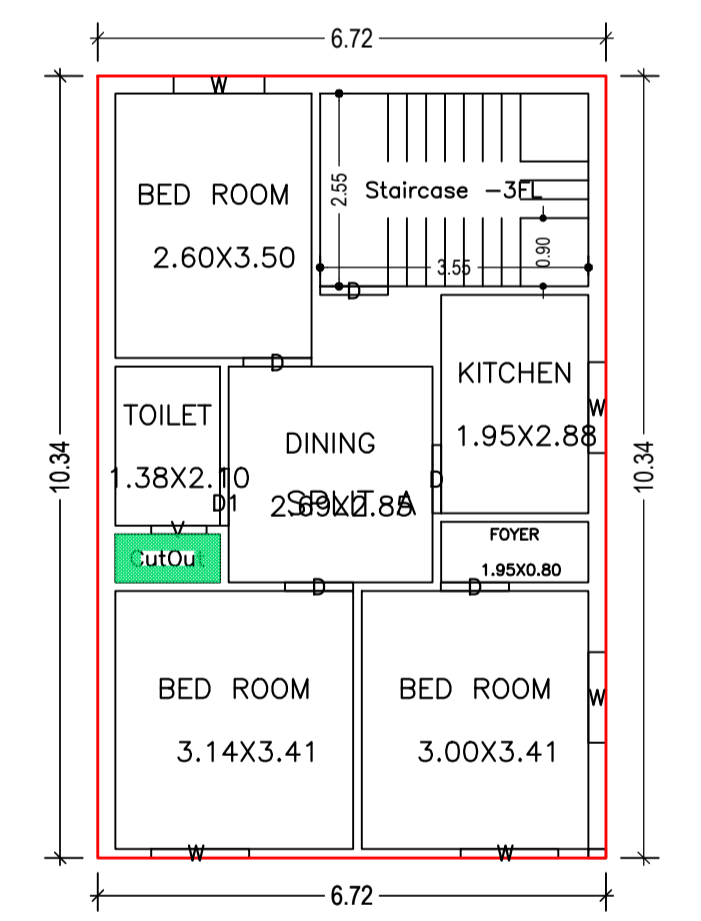
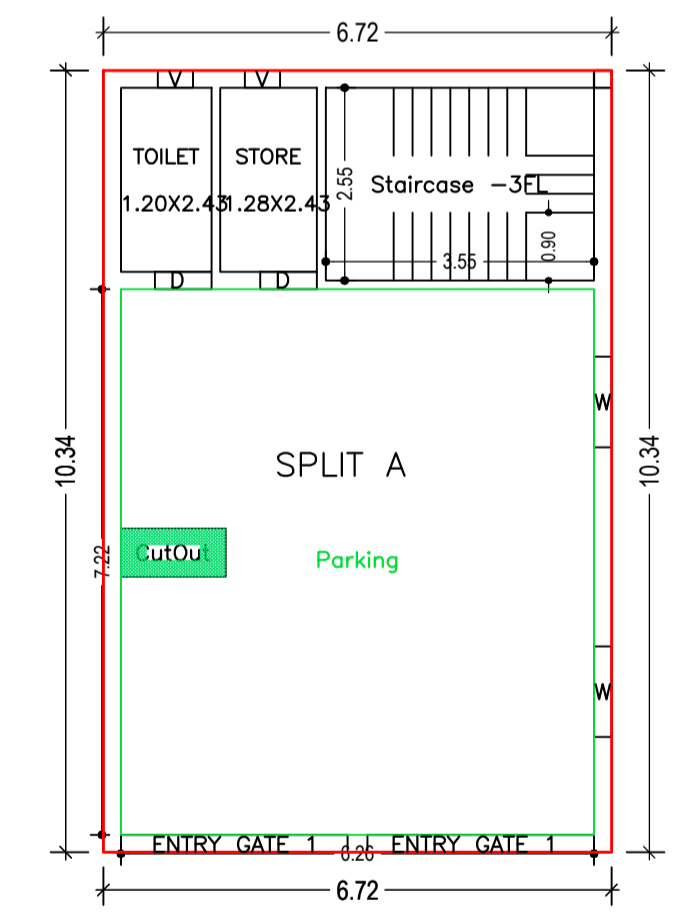
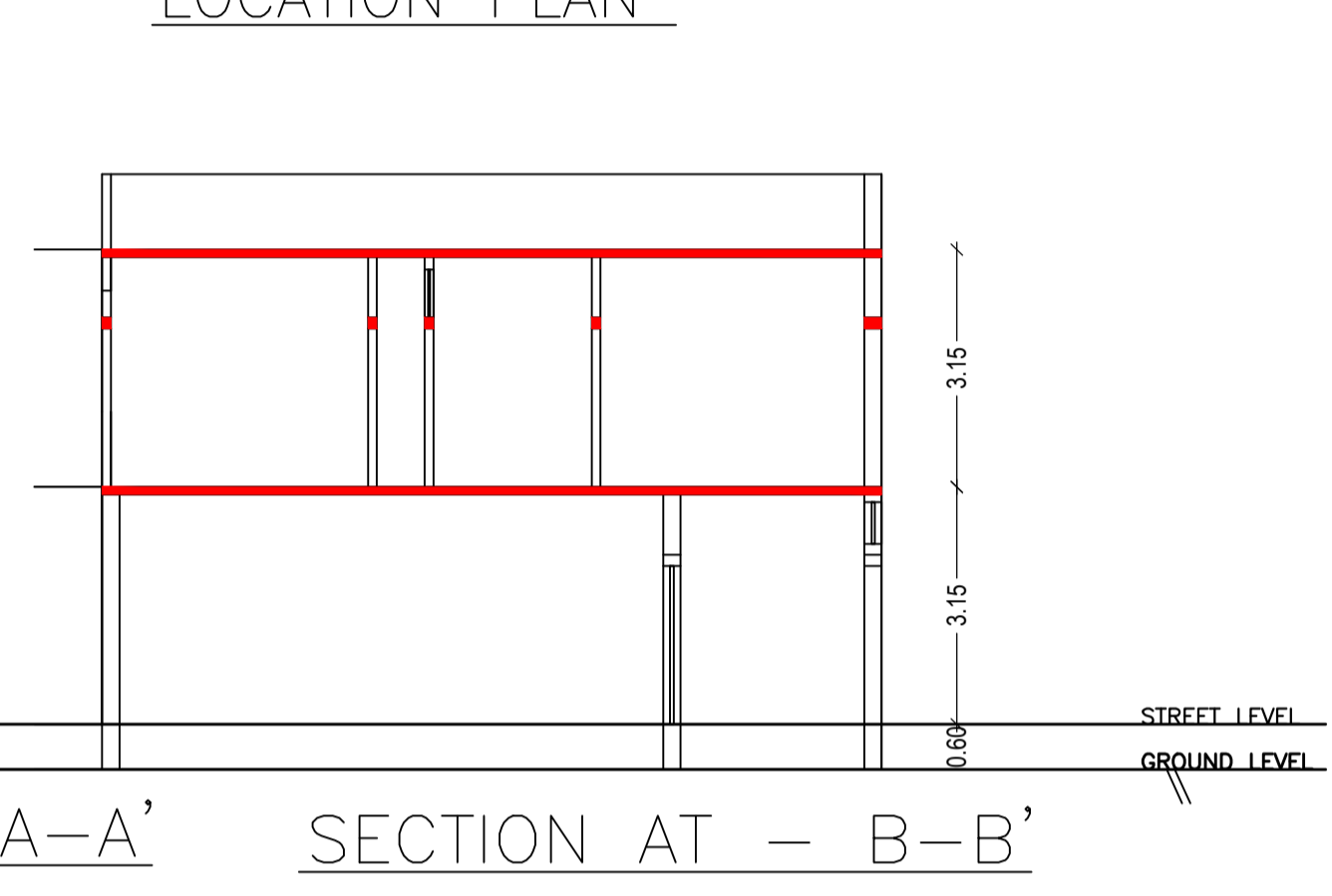
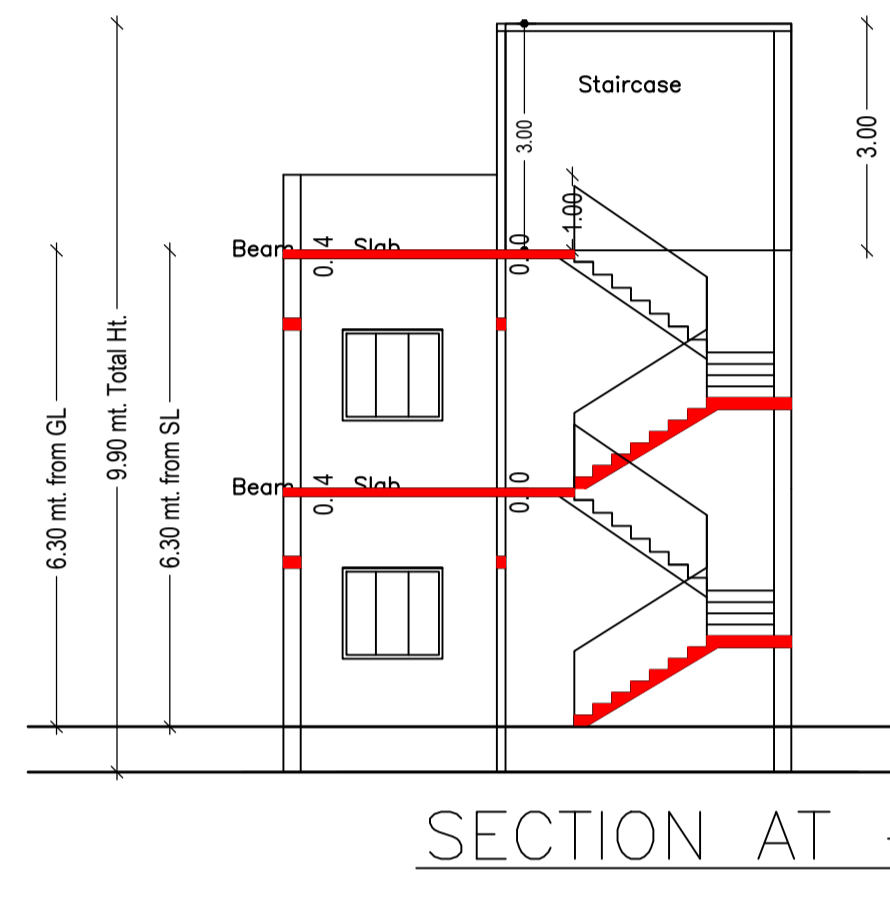
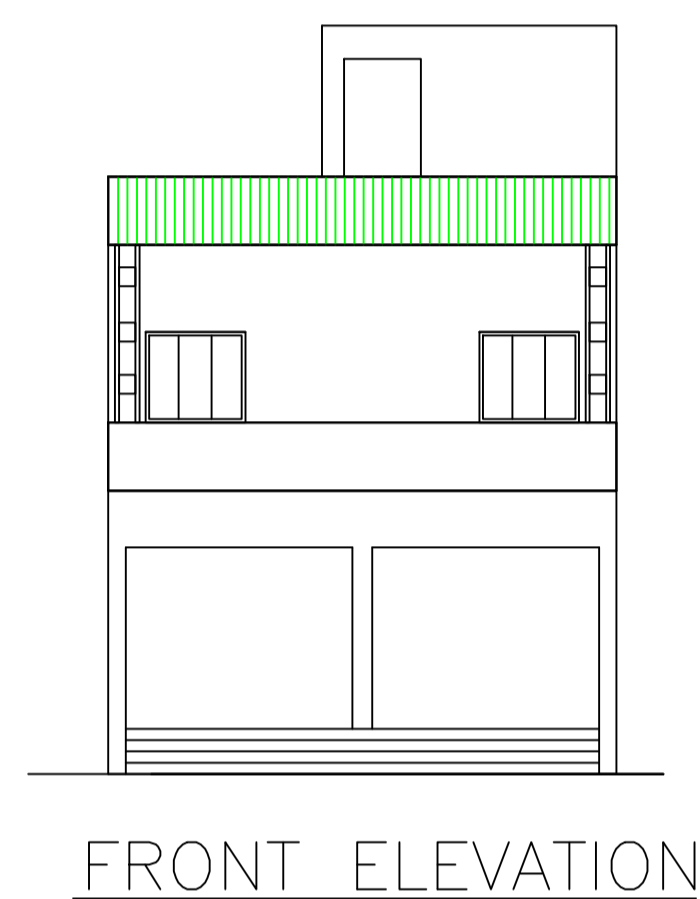

Building :A (LALPAT)

Floor Name	Gross Builtup Area	Deductions From Gross BUA/Area in Sq.mt.)	Total Built Up Area (Sq.mt.)	Proposed FAR Area (Sq.mt.)	Total FAR Area (Sq.mt.)	Total Consumed Additional FAR Area (Sq.mt.)	Tnmt (No.)
Ground Floor	70.36	0.88	69.48	69.48	69.48	69.48	01
First Floor	69.49	0.88	68.61	68.61	68.61	68.61	00
Terrace Floor	0.00	0.00	0.00	0.00	0.00	0.00	00
Total	139.85	1.76	138.09	138.09	138.09	138.09	01
Total Number of Same Buildings	1						
Total :	139.85	1.76	138.09	138.09	138.09	138.09	01

SCHEDULE OF DOOR:

BUILDING NAME	NAME	LENGTH	HEIGHT	NOS
A (LALPAT)	D1	0.75	2.10	01
A (LALPAT)	D	0.75	2.10	02
A (LALPAT)	D	0.90	2.10	04

SCHEDULE OF WINDOW/VENTILATION:

BUILDING NAME	NAME	LENGTH	HEIGHT	NOS
A (LALPAT)	V	0.47	1.20	02
A (LALPAT)	V	0.73	1.20	01
A (LALPAT)	W	1.20	1.20	03
A (LALPAT)	W	1.29	1.20	02

COLOR INDEX

PLOT BOUNDARY	Black
ABUTTING ROAD	Green
PROPOSED CONSTRUCTION	Red
COMMON PLOT	Yellow
ROAD WIDENING AREA	Blue
EXISTING (To be retained)	Blue
EXISTING (To be demolished)	Yellow

Buildingwise Floor FAR Details

Floor Name	Building Name A (LALPAT)		Total	
	Proposed Built Up Area (Sq.mt.)	Proposed FAR Area (Sq.mt.)	Total Proposed Built Up Area (Sq.mt.)	Total FAR Area (Sq.mt.)
Ground Floor	69.48	69.48	69.48	69.48
First Floor	68.61	68.61	68.61	68.61
Terrace Floor	0.00	0.00	0.00	0.00
Total :	138.09	138.09	138.09	138.09

UnitBUA Table for Building :A (LALPAT)

FLOOR	Name	UnitBUA Type	UnitBUA Area	Carpet Area	No. of Rooms	No. of Tenement
GROUND FLOOR	SPLIT A	FLAT	137.21	137.13	2	1
FIRST FLOOR	SPLIT A	FLAT	0.00	0.00	7	0
Total:	-	-	137.21	137.13	9	1

FAR & Tenement Details (Table 4c-1)

Building	No. of Same Bldg	Gross Built Up Area (Sq.mt.)	Deductions From Gross BUA/Area in Sq.mt.)	Total Built Up Area (Sq.mt.)	Proposed FAR Area (Sq.mt.)	Total FAR Area (Sq.mt.)	Total Consumed Additional FAR Area (Sq.mt.)	Tnmt (No.)
A (LALPAT)	1	139.85	1.76	138.09	138.09	138.09	138.09	01
Grand Total :	1	139.85	1.76	138.09	138.09	138.09	138.09	01

Building USE/SUBUSE Details

Building Name	Building Use	Building SubUse	Building Structure
A (LALPAT)	Residential	Bungalow/ Dwelling / Non Apartment	Non-Highrise

LTP NAME AND SIGNATURE	STRUCTURAL ENG'S NAME AND SIGNATURE	BUILDER NAME AND SIGNATURE	DIGITAL SIGNATURE
AMRIT KUMAR MAHATO CMC/DFTM/0004/2019			