

Project Title - AVINASH

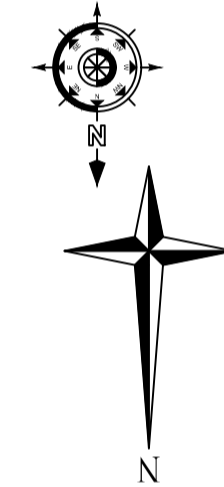
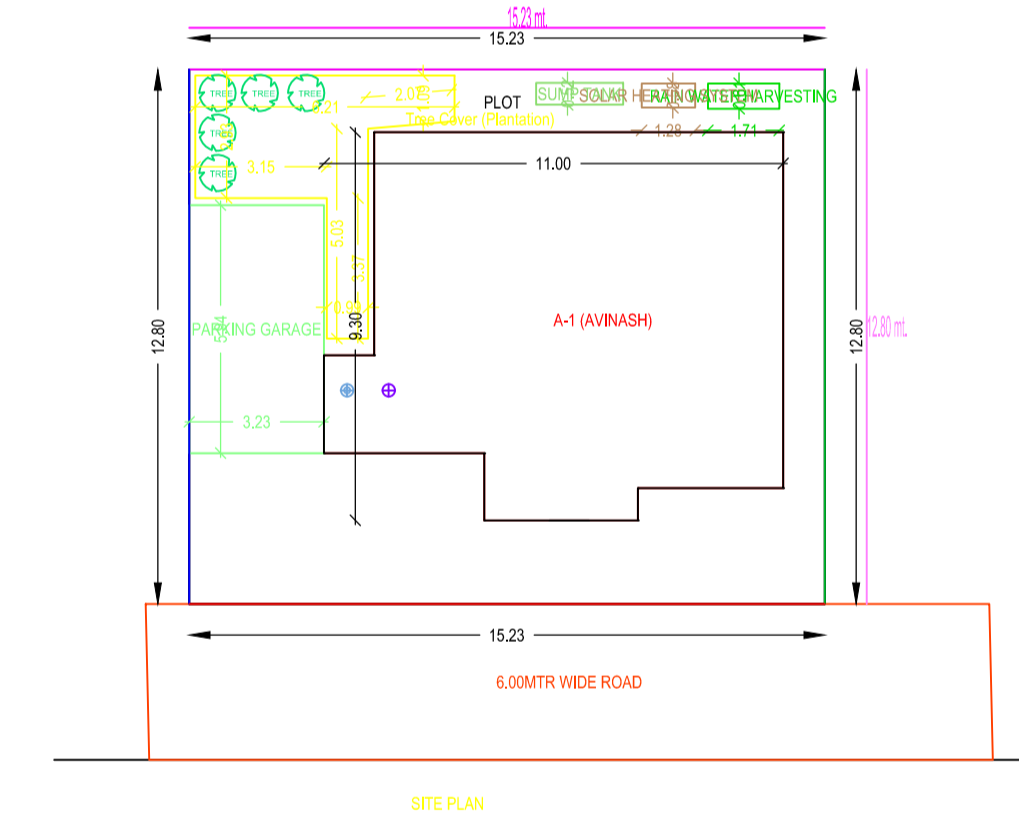
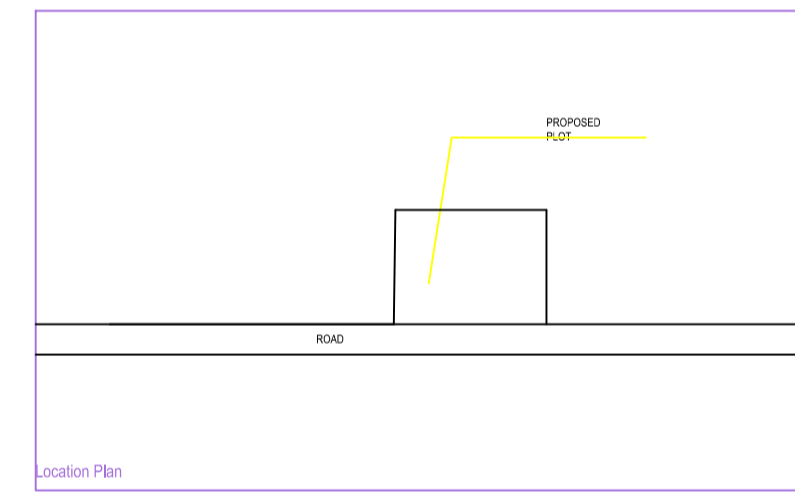
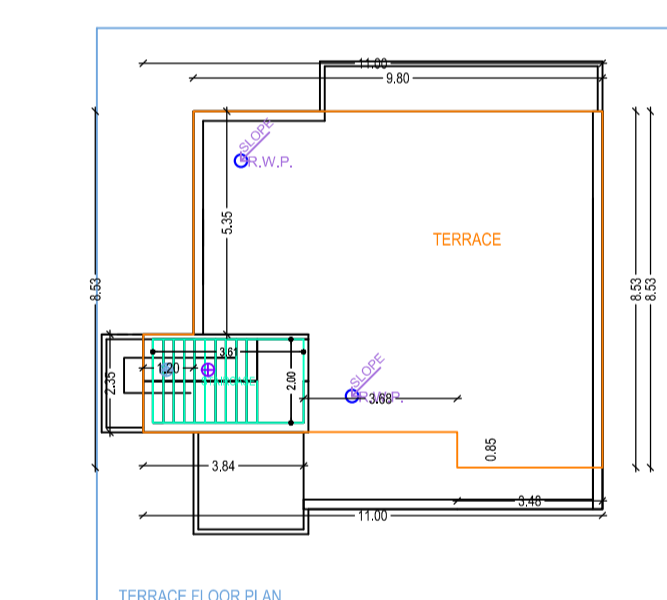
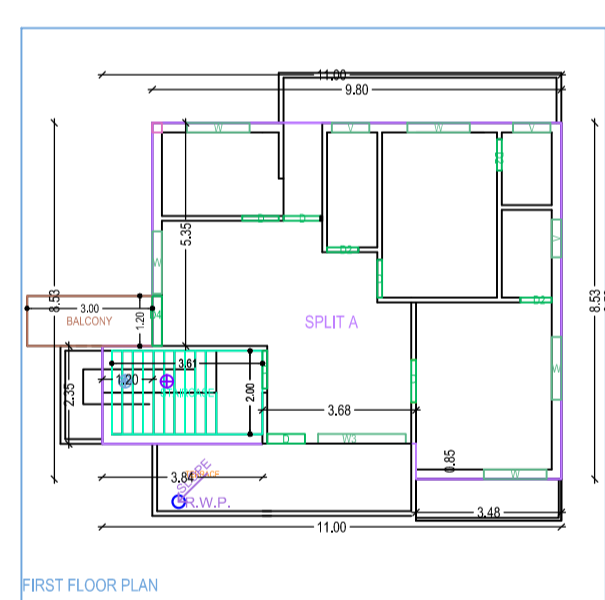
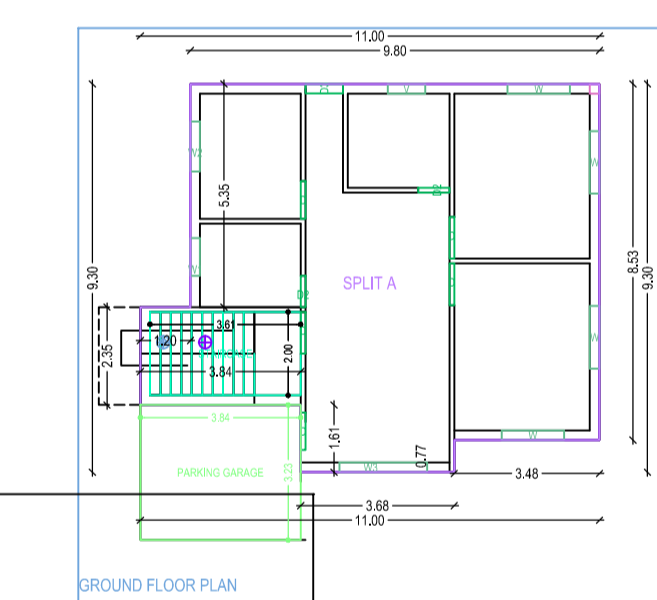
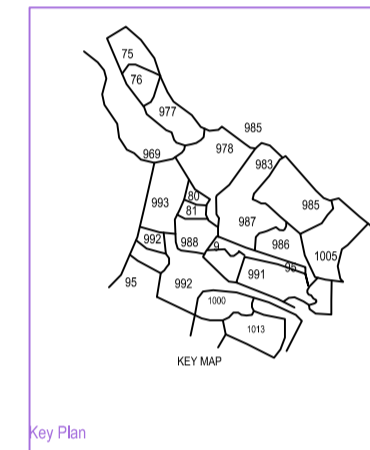
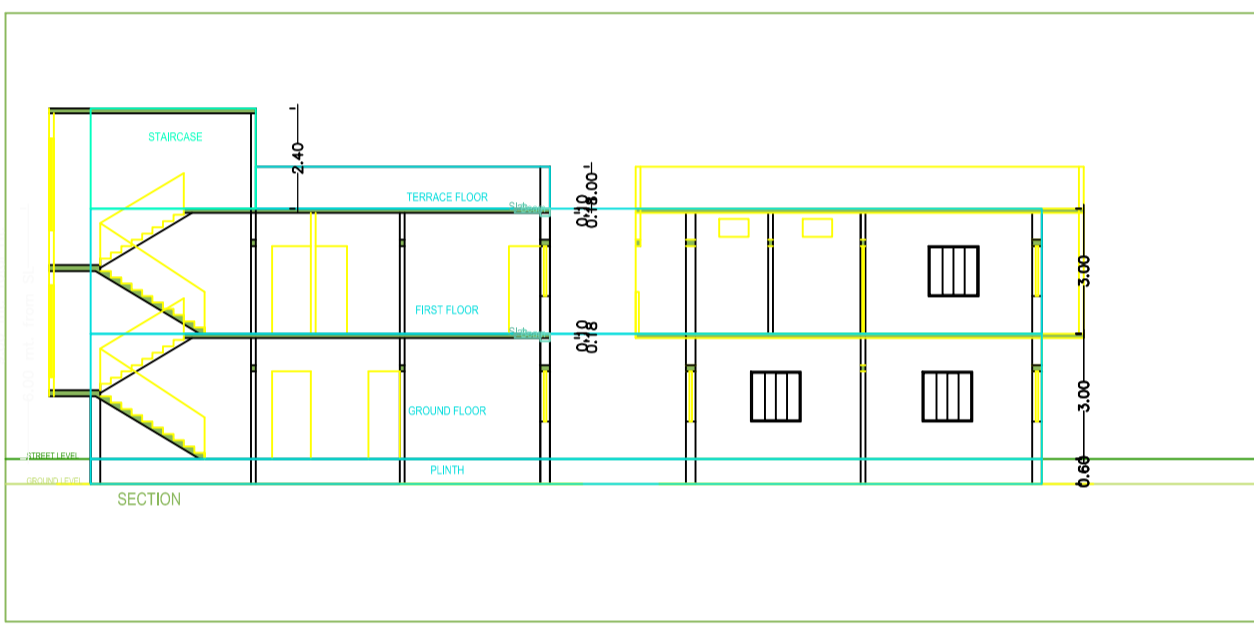
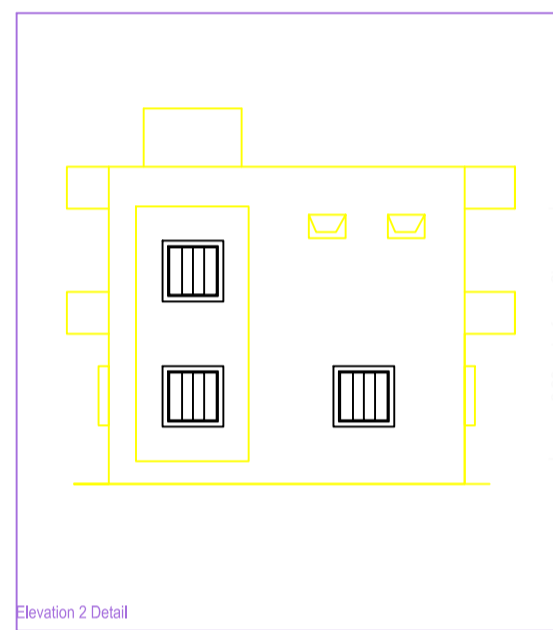
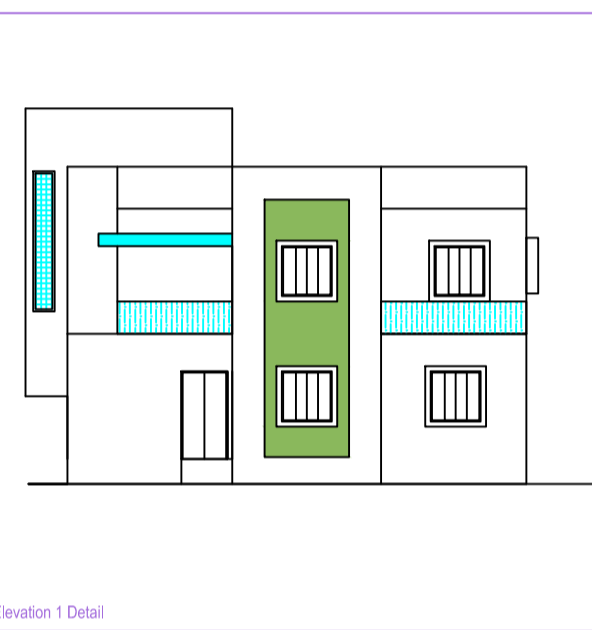
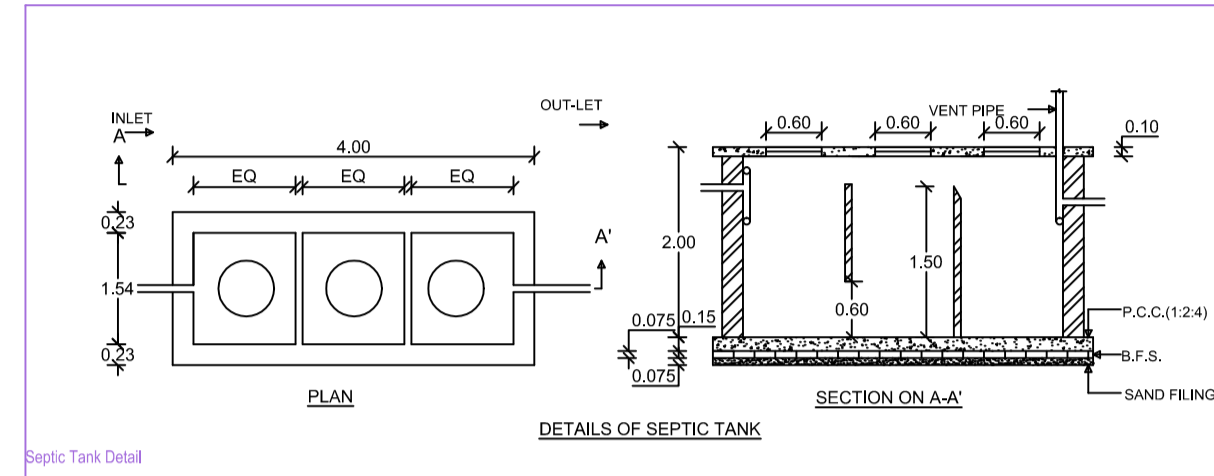
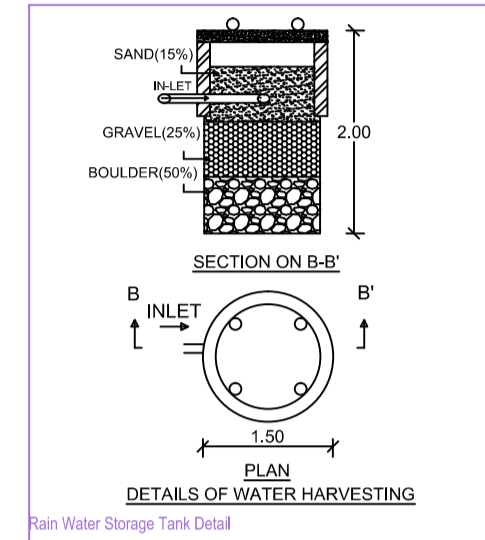
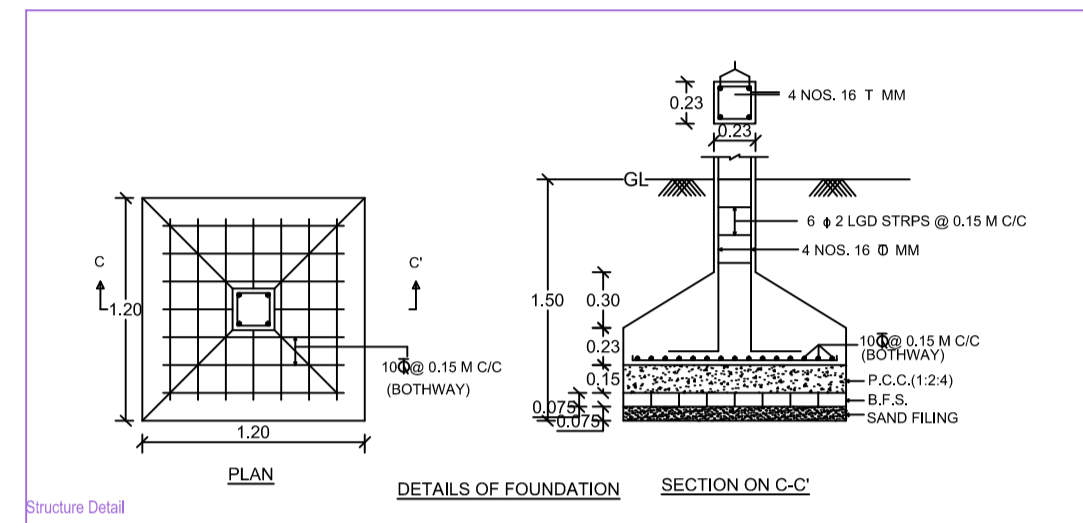

**Building A (AVINASH)**

Floor Name	Total Built Up Area (Sq.M)	Deductions Area in Sq.M		Proposed FAR Area (Sq.M)	Total FAR Area (Sq.M)	Tent (No.)
		Balcony	Accessory Use			
Ground Floor	84.88	0.00	12.42	17.02	67.52	01
First Floor	84.88	1.80	0.00	62.08	62.08	00
Terrace Floor	84.88	0.00	0.00	0.00	0.00	00
<b>Total</b>	<b>154.64</b>	<b>1.80</b>	<b>12.42</b>	<b>69.10</b>	<b>69.10</b>	<b>01</b>

**SCHEDULE OF JOINERY:**

BUILDING NAME	NAME	LENGTH	HEIGHT	NO.
AVINASH	01	0.75	2.10	05
AVINASH	02	0.88	2.10	02
AVINASH	03	0.80	2.10	01
AVINASH	04	0.80	2.10	01
AVINASH	05	1.00	2.10	01
AVINASH	06	1.00	2.10	01
AVINASH	07	1.20	2.10	01
AVINASH	08	-	-	18

**SCHEDULE OF JOINERY:**

BUILDING NAME	NAME	LENGTH	HEIGHT	NO.
AVINASH	01	0.80	1.00	04
AVINASH	02	0.80	1.00	01
AVINASH	03	1.20	1.00	01
AVINASH	04	1.00	1.00	01
AVINASH	05	2.10	1.00	02
AVINASH	06	-	-	17

**Balcony Calculations Table**

FLOOR	SIZE	AREA	TOTAL AREA
FIRST FLOOR PLAN	1.20 x 1.00 x 1 x 1	3.60	3.60
Total	-	-	3.60

**Useful Table for Building A (AVINASH)**

FLOOR	Name	USEFUL TYPE	USEFUL AREA	COVERED AREA	No. of Rooms	No. of Tenement
GROUND FLOOR PLAN	SPLIT A	FLAT	18.90	18.90	1	1
Total	-	-	18.90	18.90	1	1

**AREA STATEMENT (SCHEDULE 4)**

COMPARTMENT	VERSION NO.	DATE
PROPOSED PROJECT	1.0	18/08/2024
PROJECT NO.	AVINASH	
REPORT NO.	AVINASH	
DISTRICT	BANGALORE	
REGISTRATION NO.	AVINASH	
PROJECT TYPE	Residential	
LOCATION	AVINASH	
DATE OF DEVELOPMENT	18/08/2024	
SCALE	AS SHOWN	
DATE OF ISSUE	18/08/2024	
PROJECT NO.	AVINASH	
REPORT NO.	AVINASH	
DATE OF ISSUE	18/08/2024	

**AREA DETAILS**

DESCRIPTION	AREA (Sq.M)
Total Plot Area	154.64
Total Built Up Area	154.64
Total Deductions Area	12.42
Total FAR Area	69.10
Total Tent Area	01

**Color Index**

Color	Description
Green	Proposed FAR Area (Coverage Area)
Red	Proposed Tent Area (Coverage Area)
Blue	Proposed Road Area (Coverage Area)
Yellow	Proposed Other Area (Coverage Area)

**Color Index**

Color	Description
Green	Proposed FAR Area (Coverage Area)
Red	Proposed Tent Area (Coverage Area)
Blue	Proposed Road Area (Coverage Area)
Yellow	Proposed Other Area (Coverage Area)

**Table 40-1: FAR & Tenement Details**

Block	No. of Blocks	Total Built Up Area (Sq.M)	Deductions Area (Sq.M)	Proposed FAR Area (Sq.M)	Total FAR Area (Sq.M)	Tent (No.)
AVINASH	1	154.64	12.42	69.10	69.10	01
<b>Total</b>	<b>1</b>	<b>154.64</b>	<b>12.42</b>	<b>69.10</b>	<b>69.10</b>	<b>01</b>