

Proposal Basic Information	
Proposal File No.	CMC/BP/0151/W29/2021
Owner Name	DINESH KUMAR
Khata No	15
Plot No	133
Village Name	Telidih
Use	Residential
SubUse	Bungalow/ Dwelling / Non Apartment

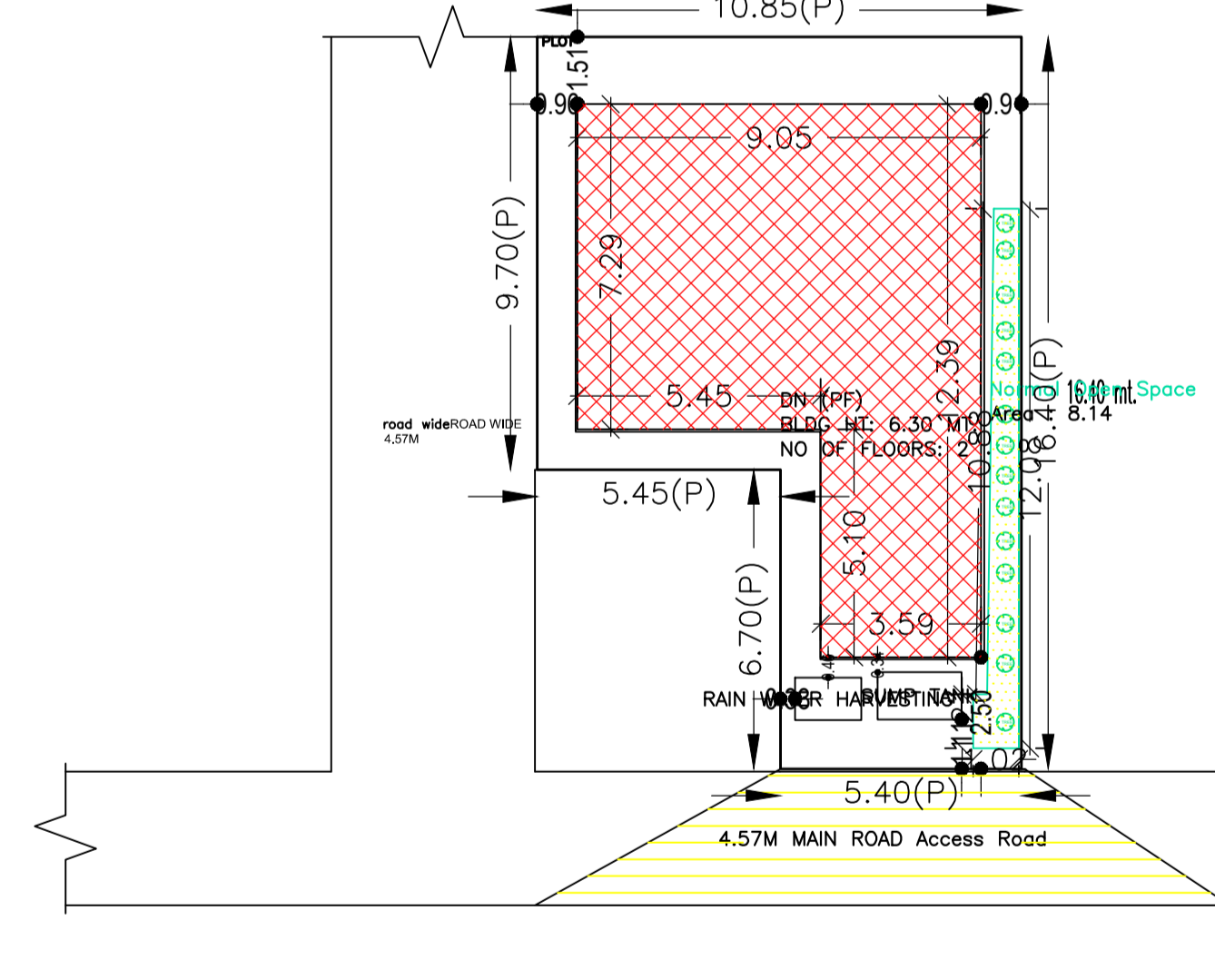
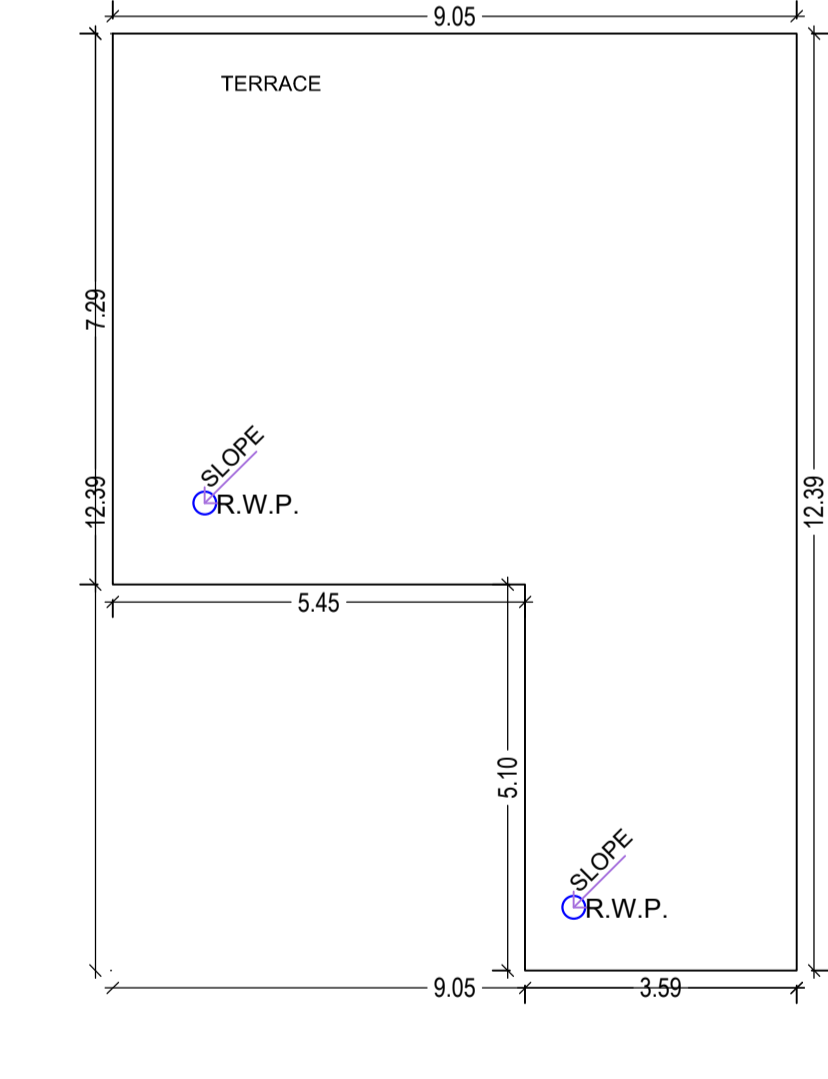
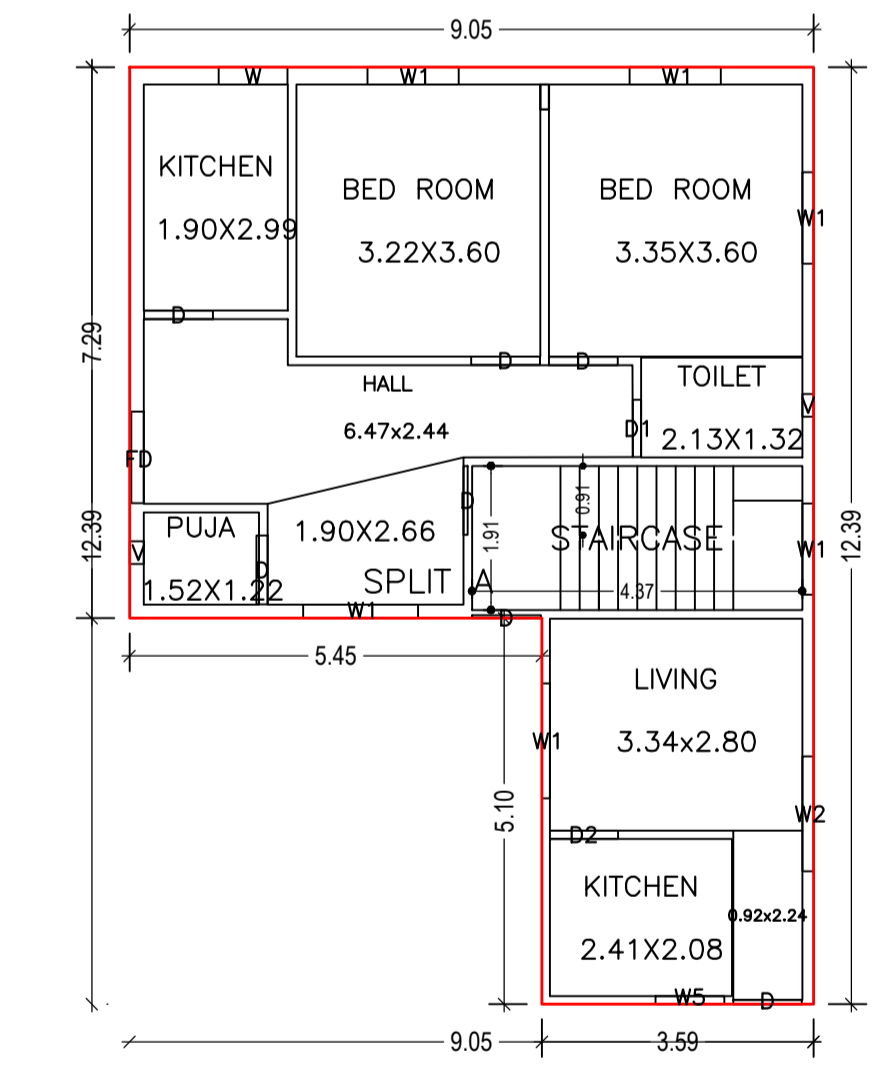
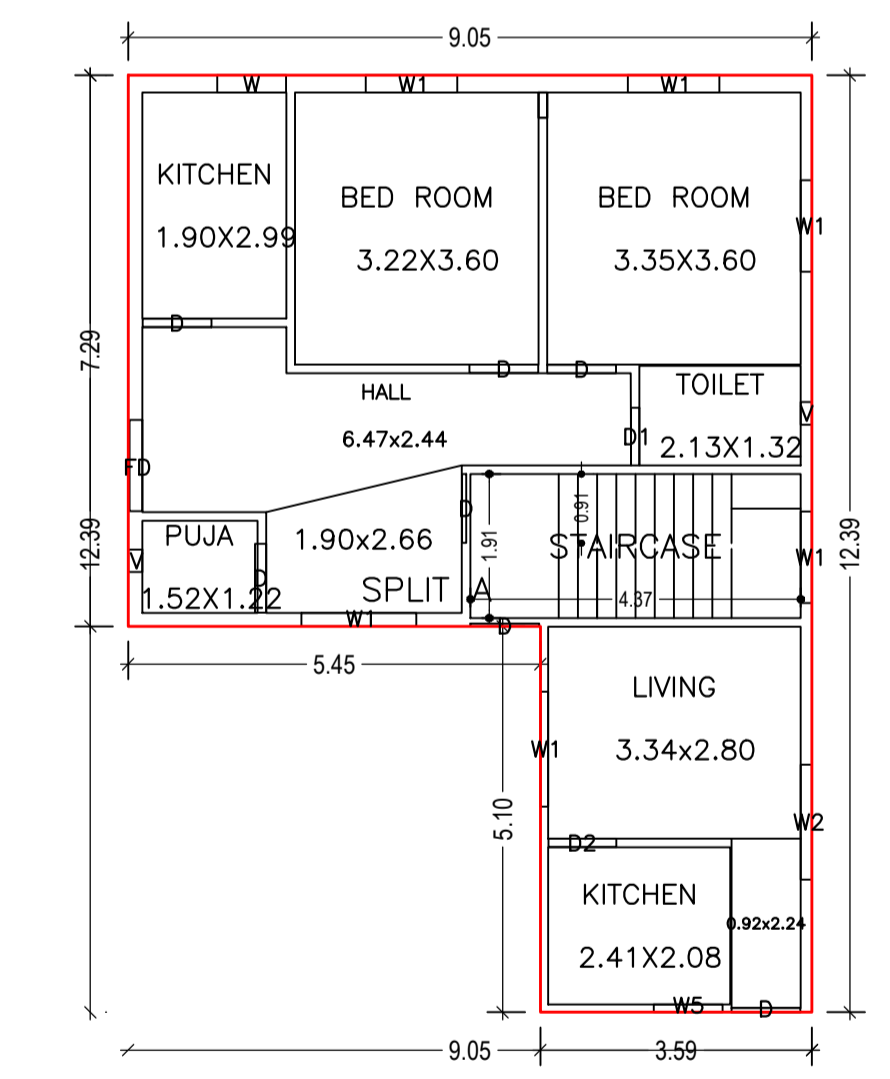
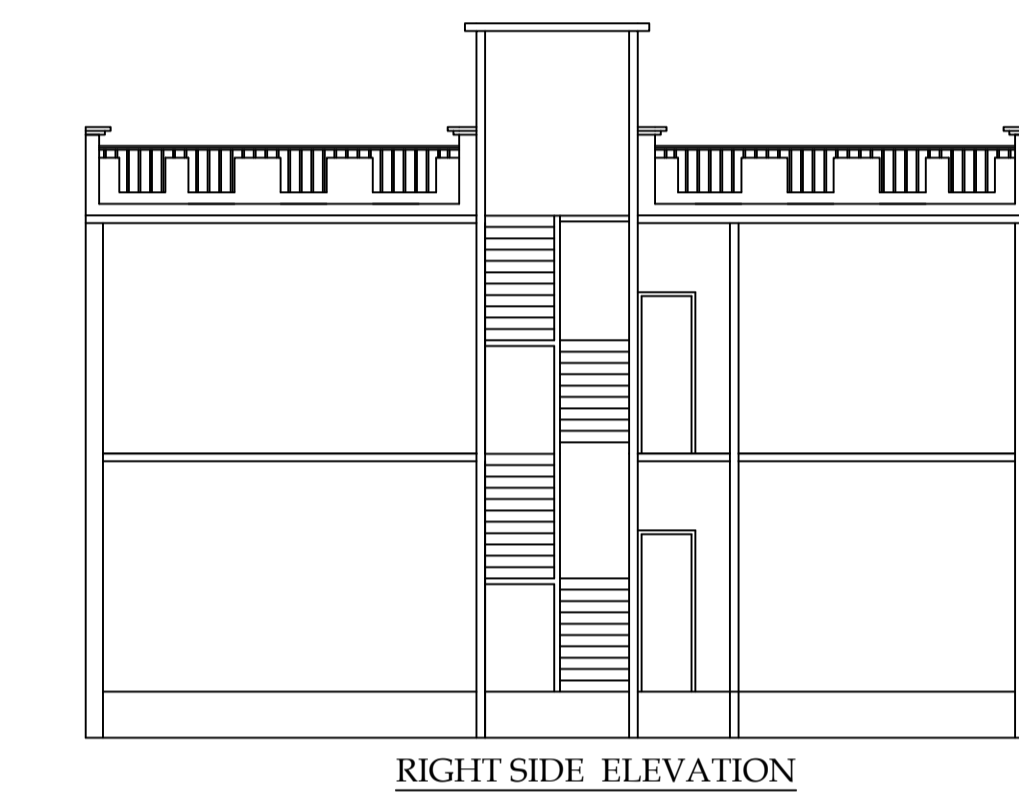
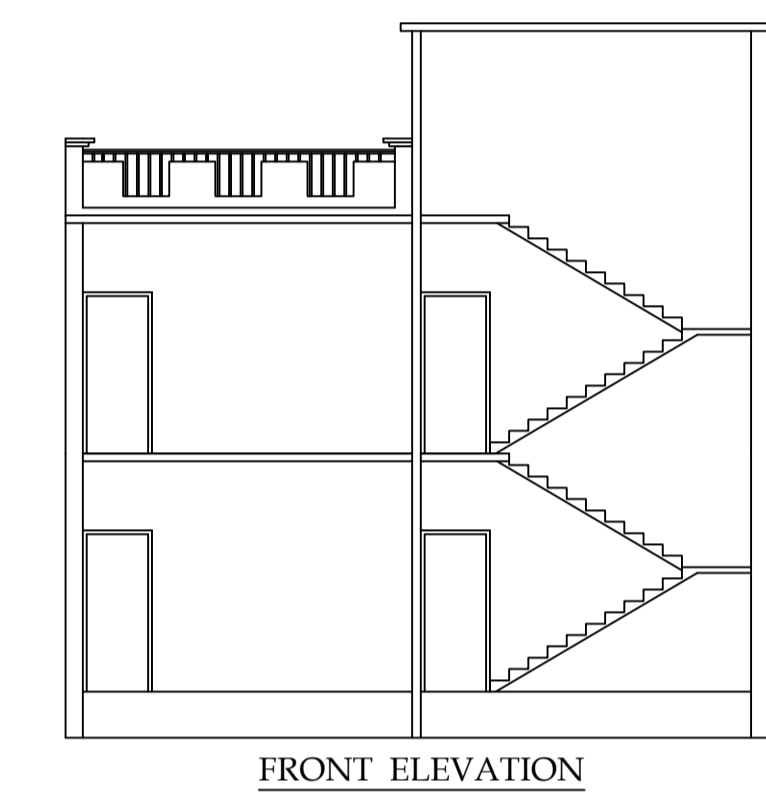
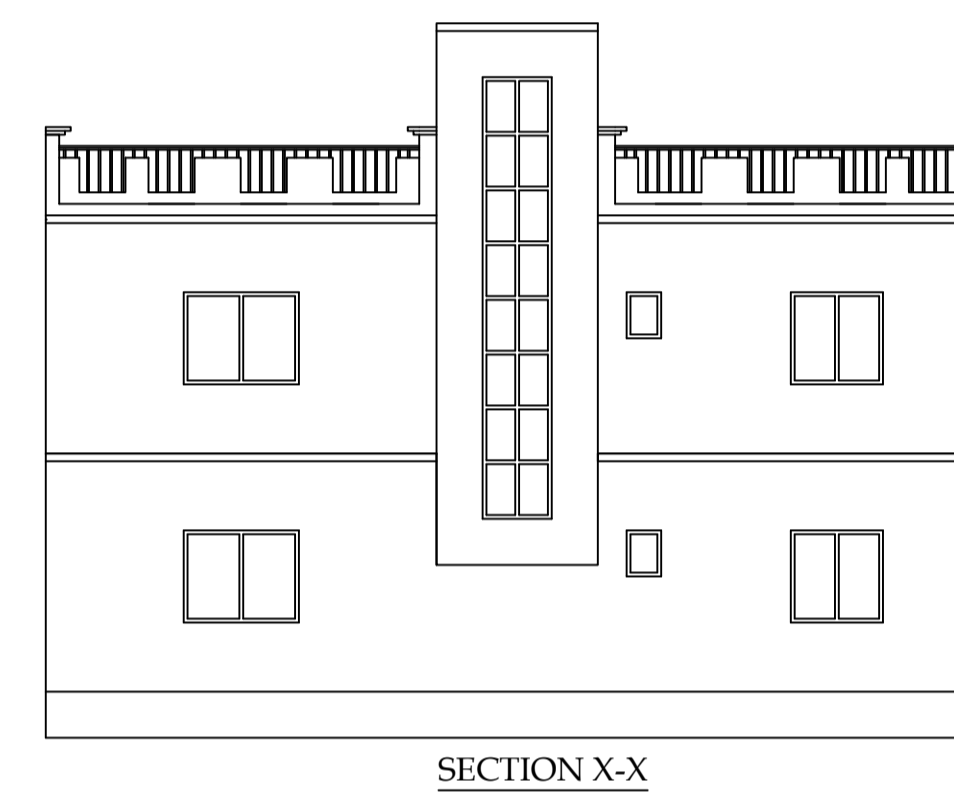
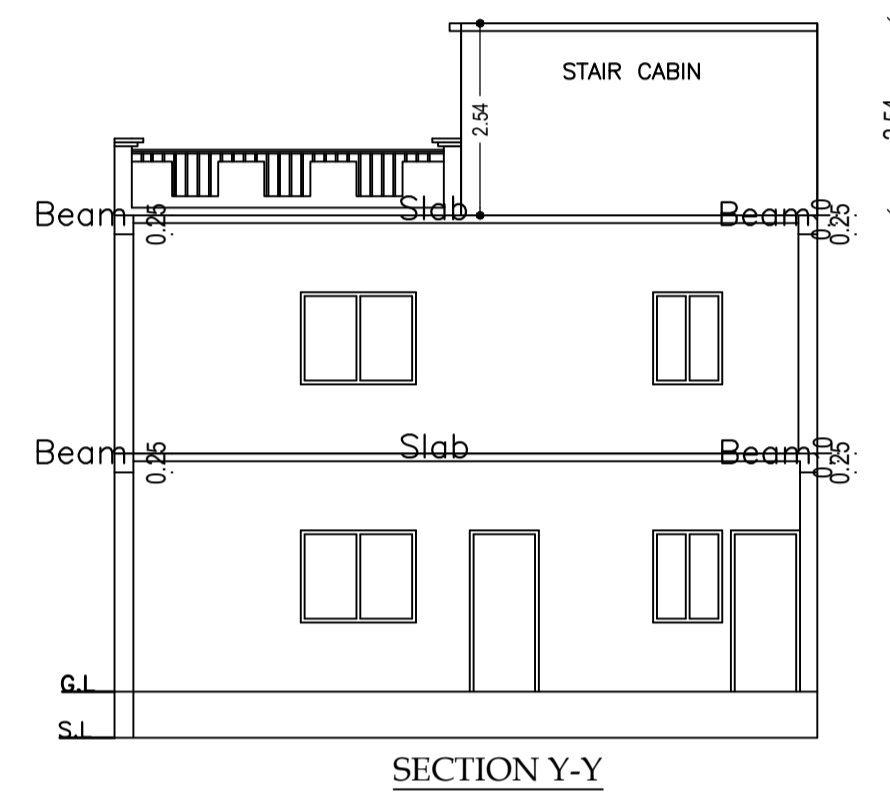
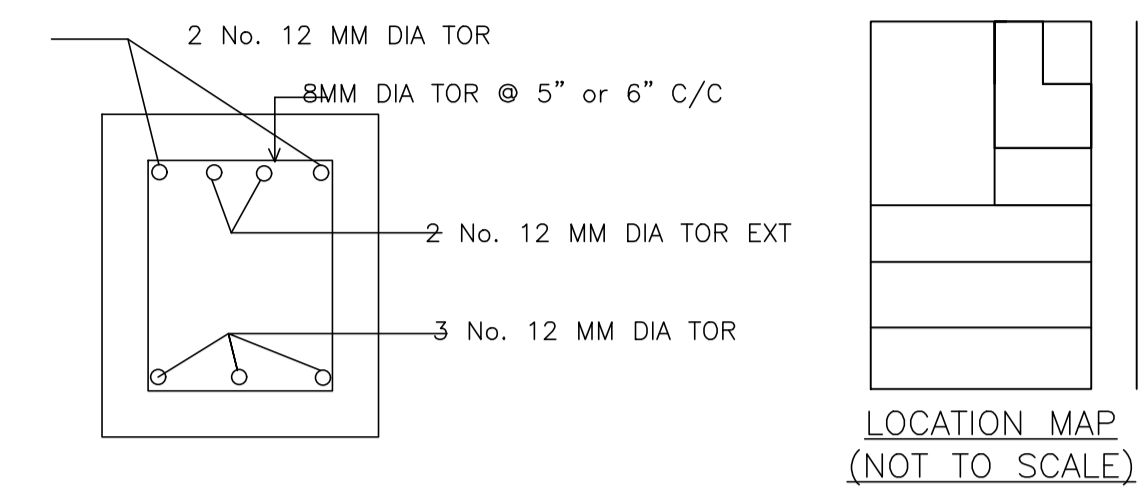
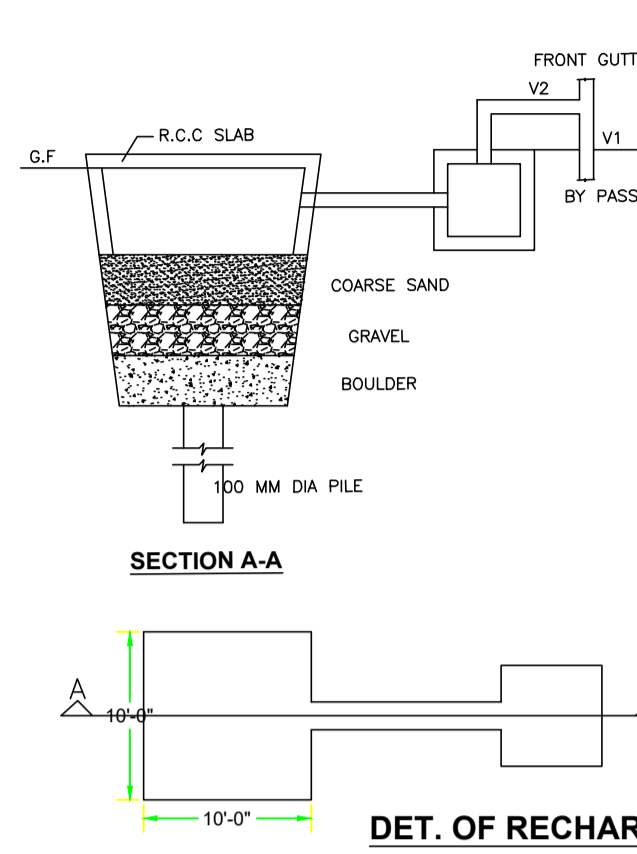
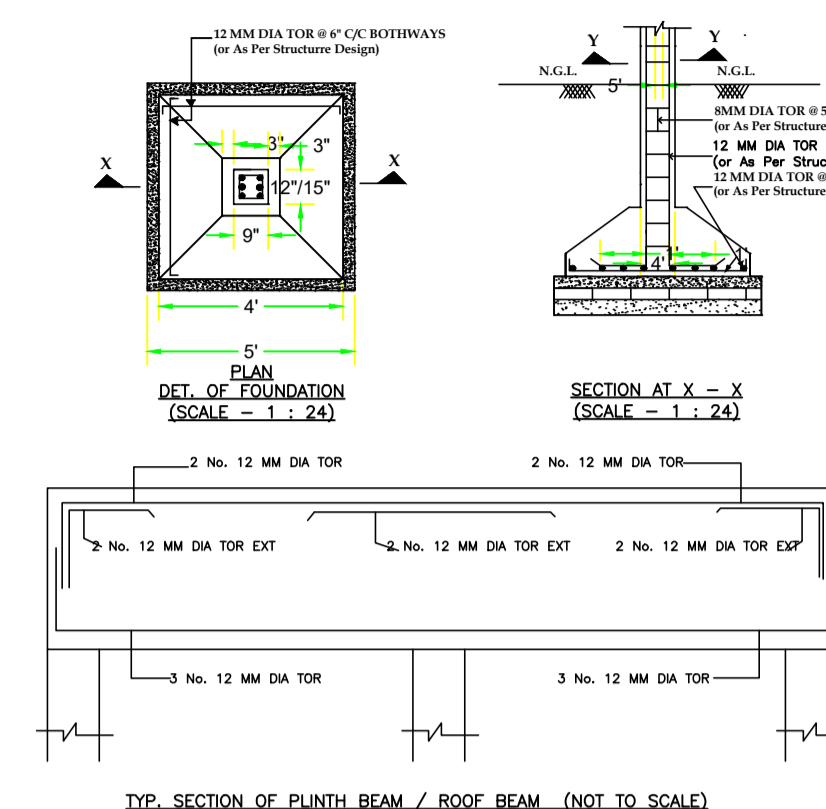
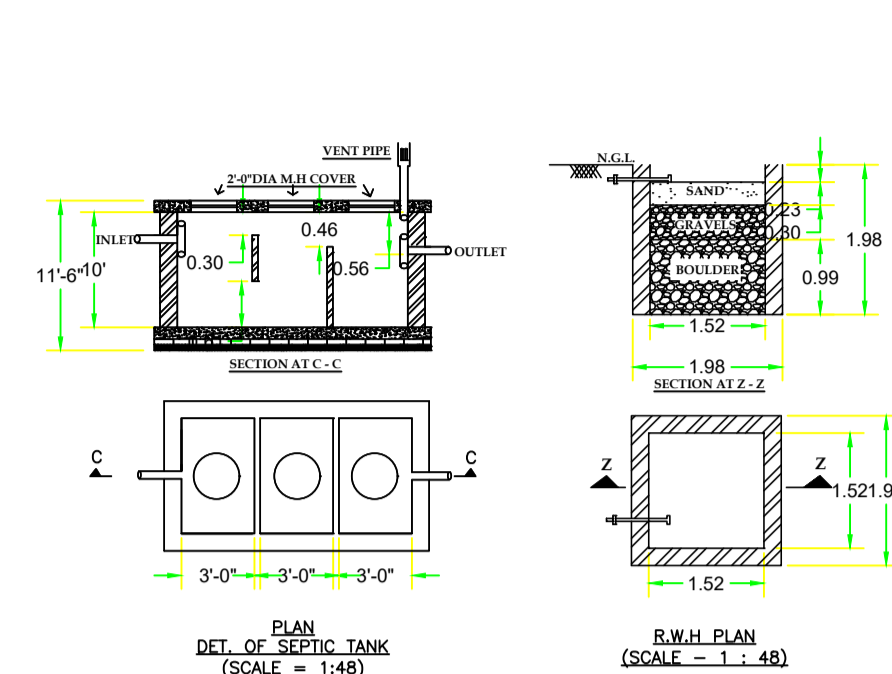

GROUND FLOOR PLAN (Proposed) (SCALE 1:100)

FIRST FLOOR PLAN (Proposed) (SCALE 1:100)

TERRACE FLOOR PLAN (SCALE 1:100)

SITE PLAN

AREA STATEMENT CHAS MUNICIPAL CORPORATION		VERSION NO.: 1.0.60	VERSION DATE: 16/10/2020
PROJECT DETAILS:			
Region: JHARKHAND URBAN LOCAL BODIES	Plot Use: Residential		
District: BOKARO	Plot SubUse: Bungalow/ Dwelling / Non Apartment		
Authority: CHAS MUNICIPAL CORPORATION	PlotNearbyReligiousStructure: NA		
Inward_No: CMC/BP/0151/W29/2021	Plot/SubPlot No: 133		
Application Type: General Proposal	North: Road Width - 4.57		
Project Type: Building Permission	South: Plot No. - 133		
Nature of Development: New	East: Road Width - 6.70		
Location of Development Area: Old Area	West: Plot No. - SANJIV KUMAR SINGH		
AREA DETAILS:			
AREA OF PLOT (Minimum)	(A)		SQ.MT. 141.44
NET AREA OF PLOT(Gross Plot Area - Deduction from Gross Plot area)	(A-Deductions)		141.44
Deduction for Balance Plot Area(from Gross Plot Area)			
Common Plot			8.14
Total			8.14
BALANCE AREA OF PLOT(Net Plot Area - Recreational/Amenity space)	(A-Deductions)		133.30
PLOT AREA FOR COVERAGE(Net Plot Area)	(A-Deductions)		141.44
Plot Area for FAR (Net Plot Area + RoadWidening Area)	(A-Deductions)		141.44
COVERAGE CHECK			
Permissible Coverage area (70.00 %)			99.01
Proposed Coverage Area (59.58 %)			84.27
Total Prop. Coverage Area (59.58 %)			84.27
Balance coverage area (10.42 %)			14.74
FAR CHECK			
Perm. FAR Area (1.50)			212.16
Total Perm. FAR area			212.16
Residential FAR			168.53
Proposed FAR Area			168.53
Total Proposed FAR Area			168.53
Consumed FAR (Factor)			1.19
Balance FAR Area			43.63
BUILT UP AREA CHECK			
Total Proposed BuiltUp Area			168.54
ARCHITECT (Regd)			NITISH PRAJAPATI
ENGINEER (Regd)			
SUPERVISOR (Regd)			
OWNER (Regd)			DINESH KUMAR
DEVELOPMENT AUTHORITY			LOCAL BODY

SCHEDULE OF DOOR:

BUILDING NAME	NAME	LENGTH	HEIGHT	NOS
DN (PF)	D1	0.76	2.10	02
DN (PF)	D2	0.90	2.10	02
DN (PF)	D	0.91	2.10	12
DN (PF)	FD	1.21	2.10	02

SCHEDULE OF WINDOW/VENTILATION:

BUILDING NAME	NAME	LENGTH	HEIGHT	NOS
DN (PF)	V	0.30	1.20	04
DN (PF)	W	0.91	1.20	02
DN (PF)	W5	0.91	1.20	02
DN (PF)	W1	1.21	1.20	08
DN (PF)	W2	1.52	1.20	02
DN (PF)	W1	1.52	1.20	04

Building :DN (PF)

Floor Name	Total Built Up Area (Sq.mt.)	Proposed FAR Area (Sq.mt.) Resi.	Total FAR Area (Sq.mt.)	Total Consumed Additional FAR Area (Sq.mt.)	Tnmt (No.)
Ground Floor	84.27	84.27	84.27	84.27	01
First Floor	84.27	84.27	84.27	84.27	00
Terrace Floor	0.00	0.00	0.00	0.00	00
Total :	168.54	168.54	168.54	168.54	01
Total Number of Same Buildings :	1				
Total :	168.54	168.54	168.54	168.54	01

FAR & Tenement Details (Table 4c-1)

Building	No. of Same Bldg	Total Built Up Area (Sq.mt.)	Proposed FAR Area (Sq.mt.) Resi.	Total FAR Area (Sq.mt.)	Total Consumed Additional FAR Area (Sq.mt.)	Tnmt (No.)
DN (PF)	1	168.54	168.54	168.54	168.54	01
Grand Total :	1	168.54	168.54	168.54	168.54	01

Buildingwise Floor FAR Details

Floor Name	Building Name		Total	
	Proposed Built Up Area (Sq.mt.)	Proposed FAR Area (Sq.mt.)	Total Proposed Built Up Area (Sq.mt.)	Total FAR Area (Sq.mt.)
Ground Floor	84.27	84.27	84.27	84.27
First Floor	84.27	84.27	84.27	84.27
Terrace Floor	0.00	0.00	0.00	0.00
Total :	168.54	168.54	168.54	168.54

UnitBUA Table for Building :DN (PF)

FLOOR	Name	UnitBUA Type	UnitBUA Area	Carpet Area	No. of Rooms	No. of Tenement
GROUND FLOOR PLAN	SPLIT A	FLAT	135.86	135.78	8	1
FIRST FLOOR PLAN	SPLIT A	FLAT	0.00	0.00	8	0
Total:	-	-	135.86	135.78	16	1

COLOR INDEX

PLOT BOUNDARY	Black
ABUTTING ROAD	Red
PROPOSED CONSTRUCTION	Green
COMMON PLOT	Blue
ROAD WIDENING AREA	Yellow
EXISTING (To be retained)	Orange
EXISTING (To be demolished)	Purple

LTP NAME AND SIGNATURE	STRUCTURAL ENG'S NAME AND SIGNATURE	BUILDER NAME AND SIGNATURE	DIGITAL SIGNATURE
NITISH PRAJAPATI CMC/DFTM/007/2020			

Building USE/SUBUSE Details

Building Name	Building Use	Building SubUse	Building Structure
DN (PF)	Residential	Bungalow/ Dwelling / Non Apartment	Non-Highrise