

Proposal Basic Information	
Proposal File No.	CMC/BP/0196/W07/2021
Owner Name	ASHA DEVI
Khata No	194
Plot No	3801
Village Name	Chas
Use	Residential
SubUse	Bungalow/ Dwelling / Non Apartment

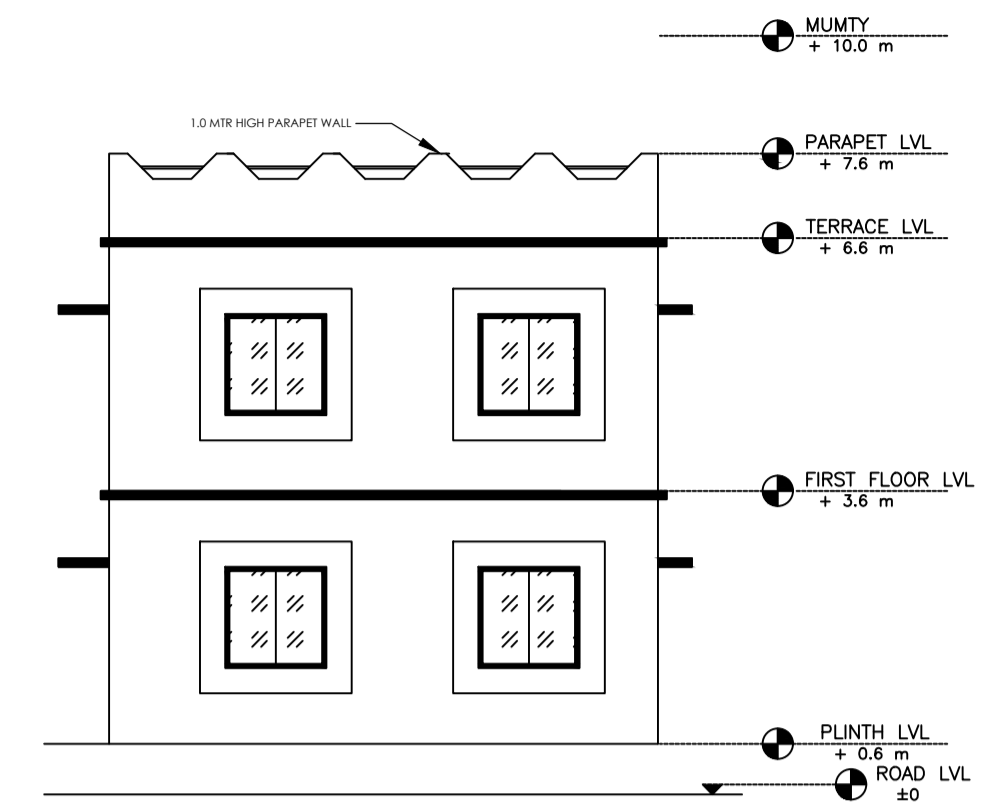

SIDE ELEVATION

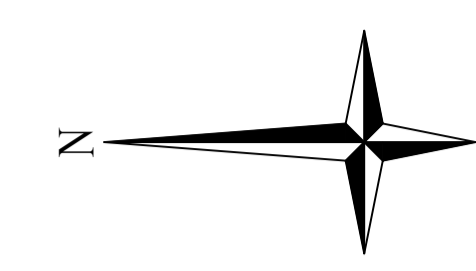
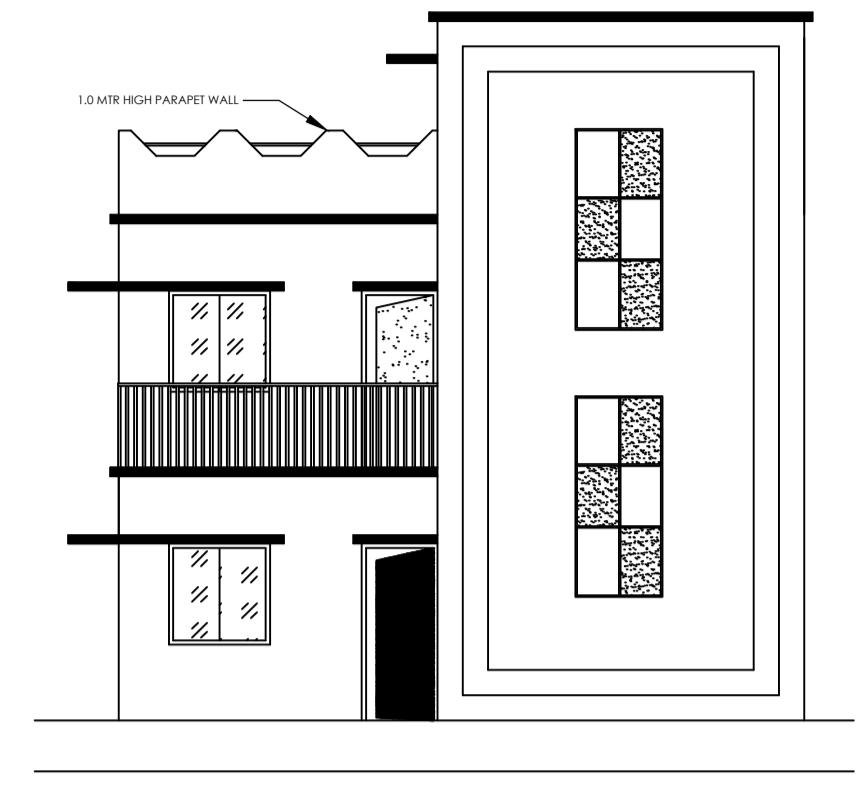

FRONT ELEVATION

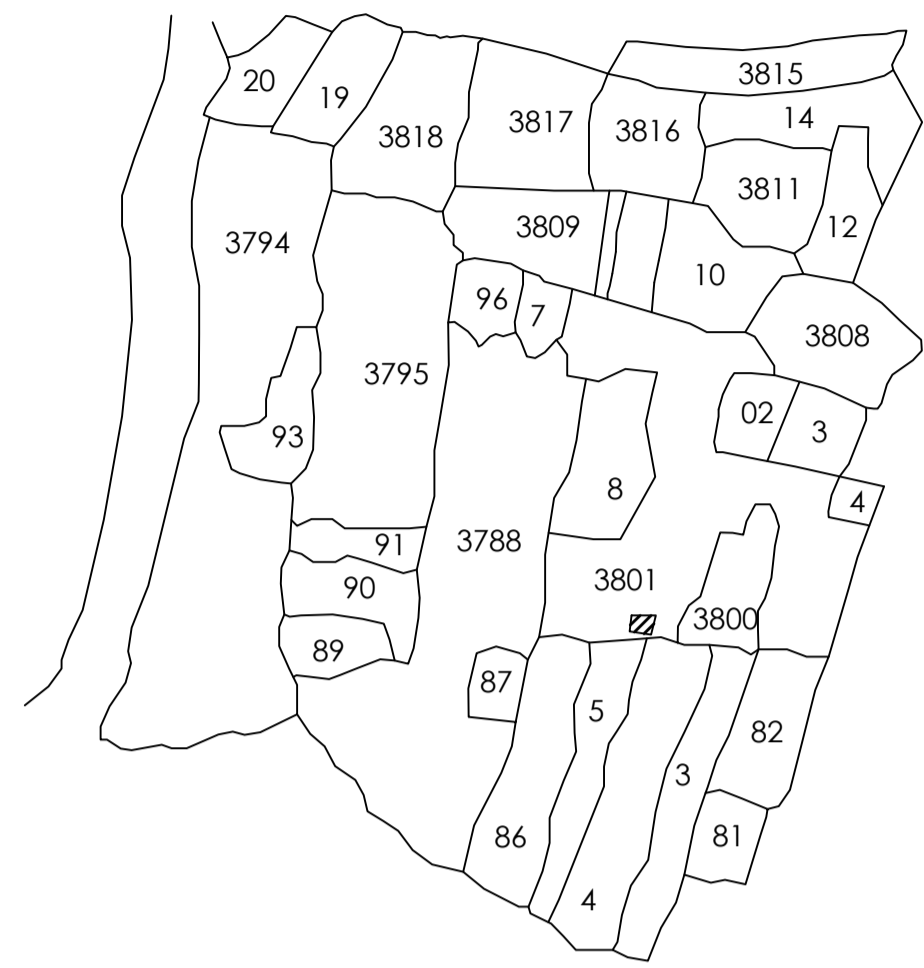

KEY MAP

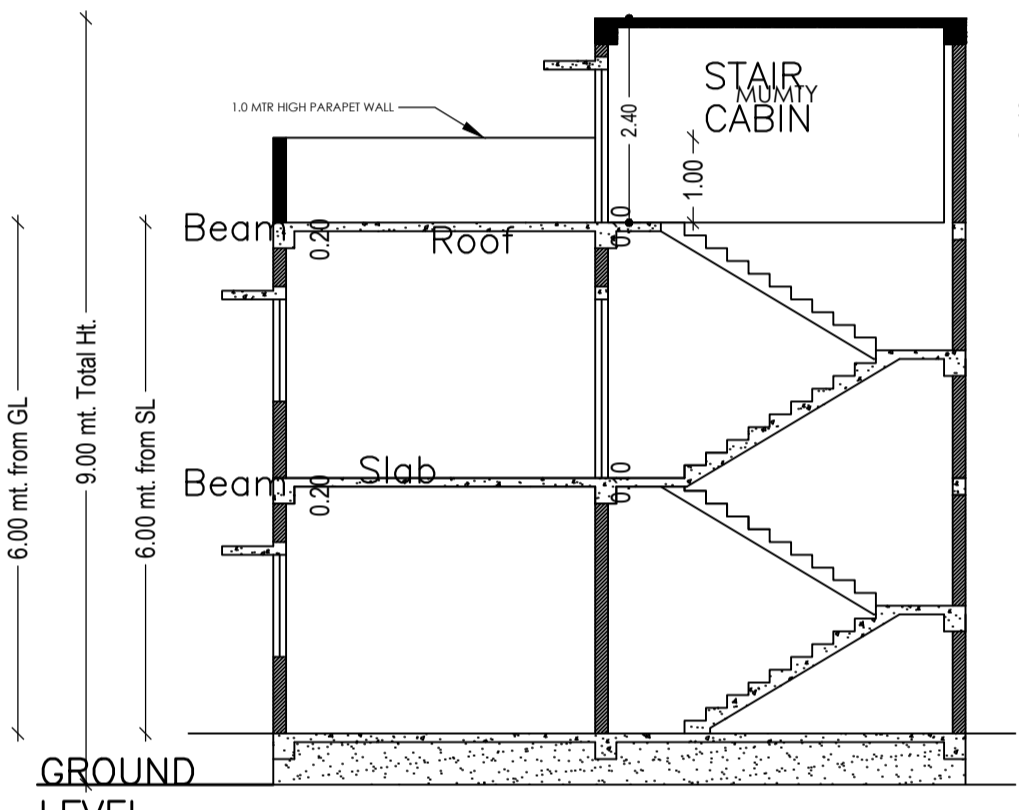
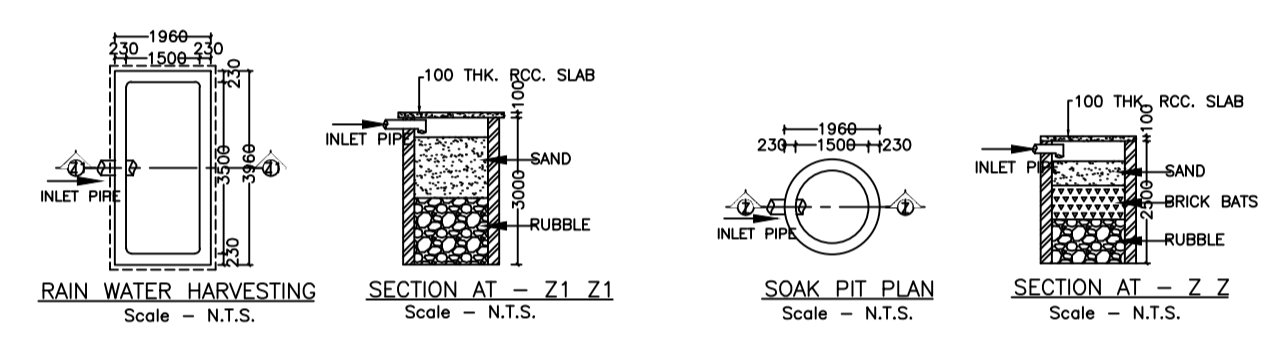
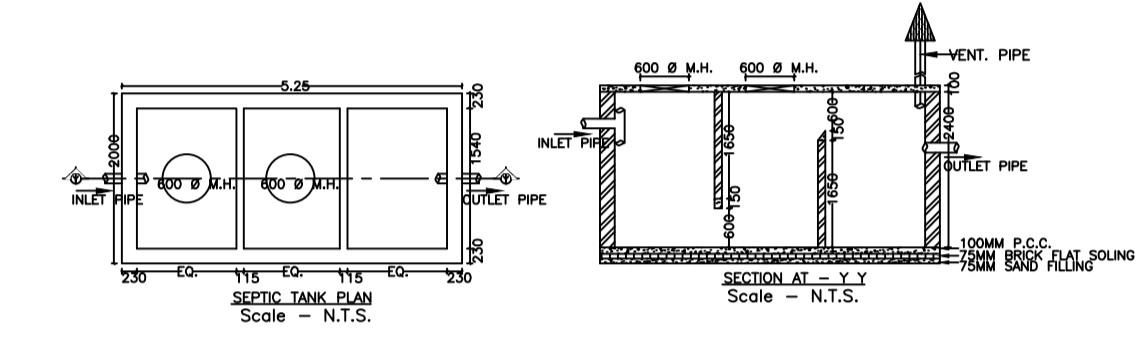
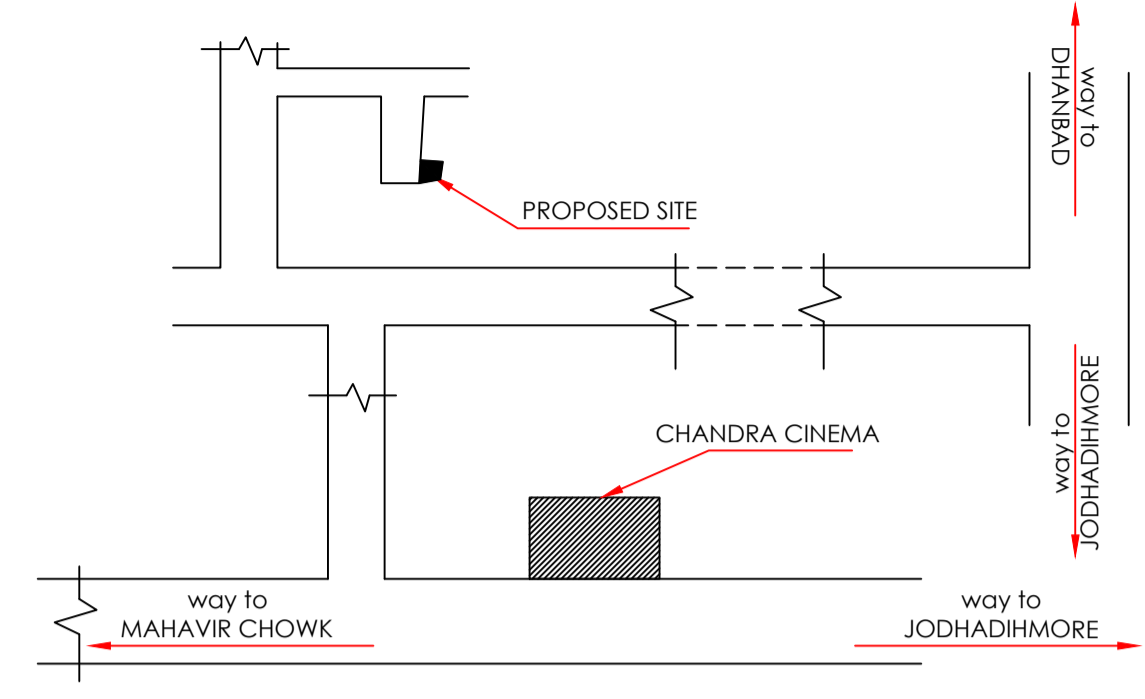

SECTION X - X'

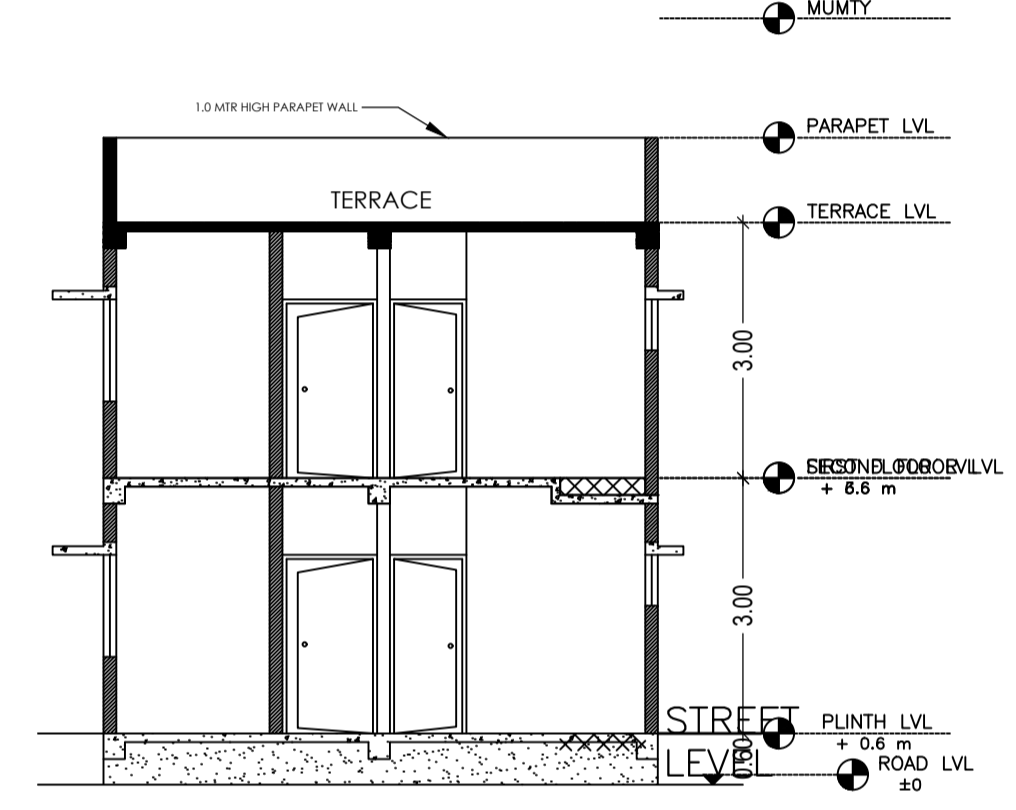

SECTION Y - Y'

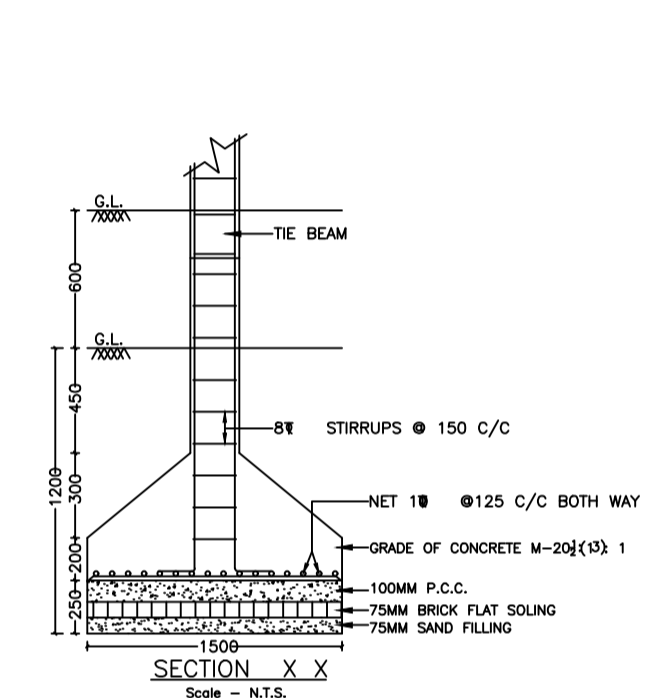

DETAILS OF COLUMN FOUNDATION

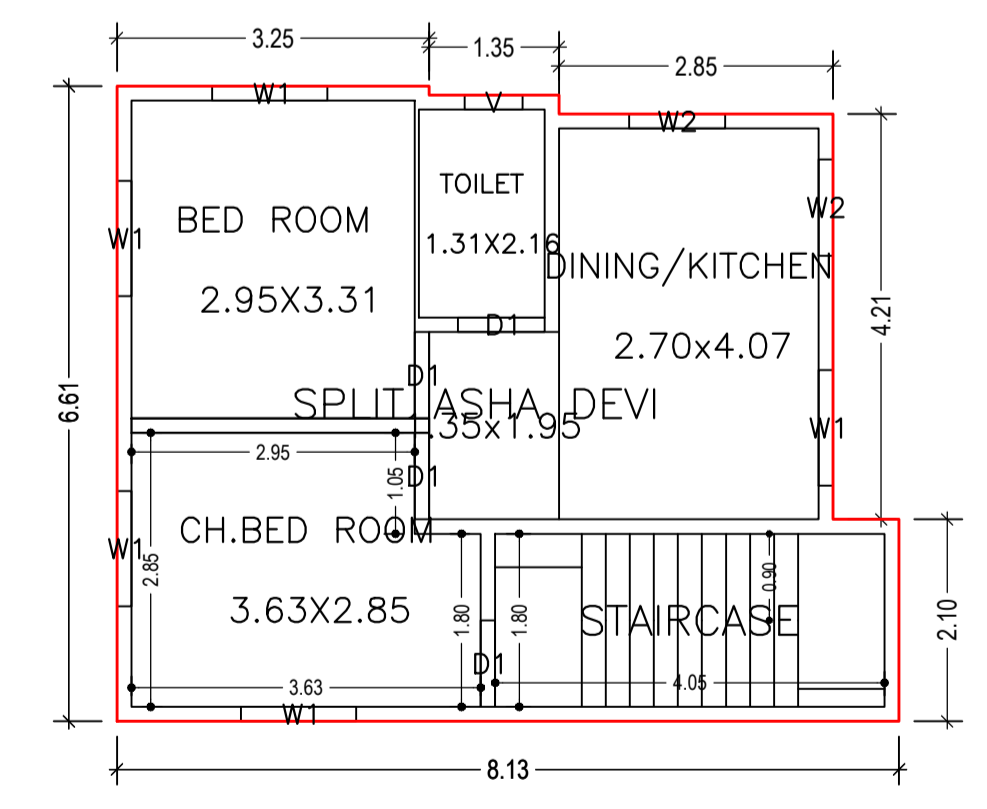

GROUND FLOOR PLAN (Proposed) (SCALE 1:100)

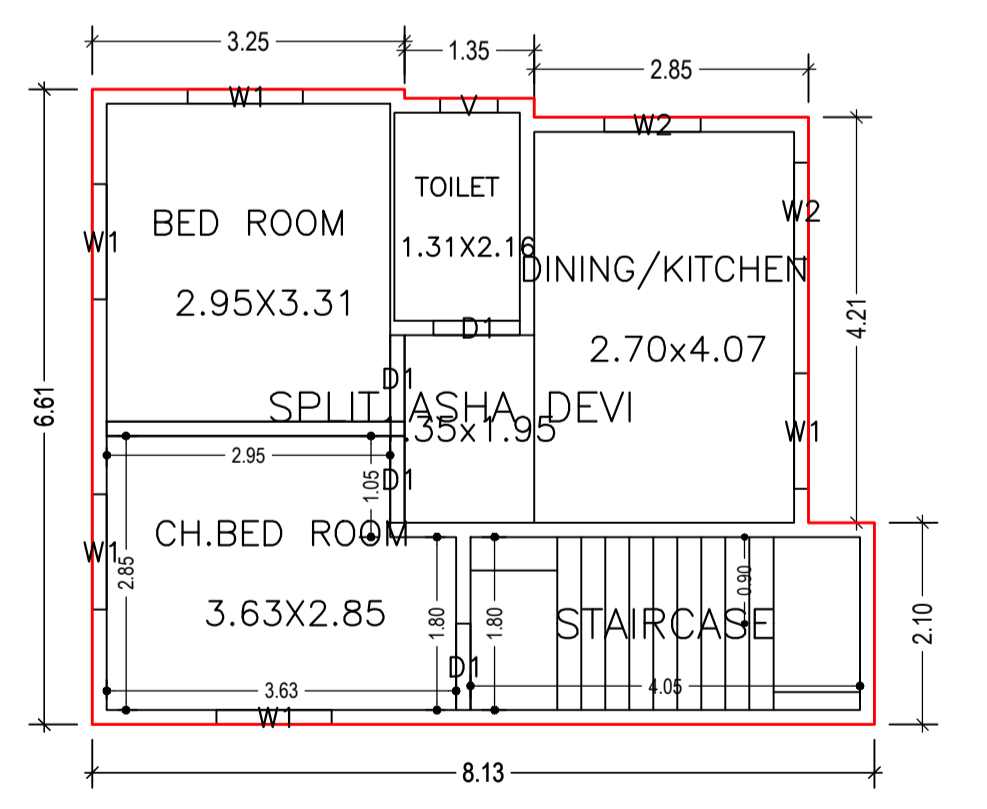

FIRST FLOOR PLAN (Proposed) (SCALE 1:100)

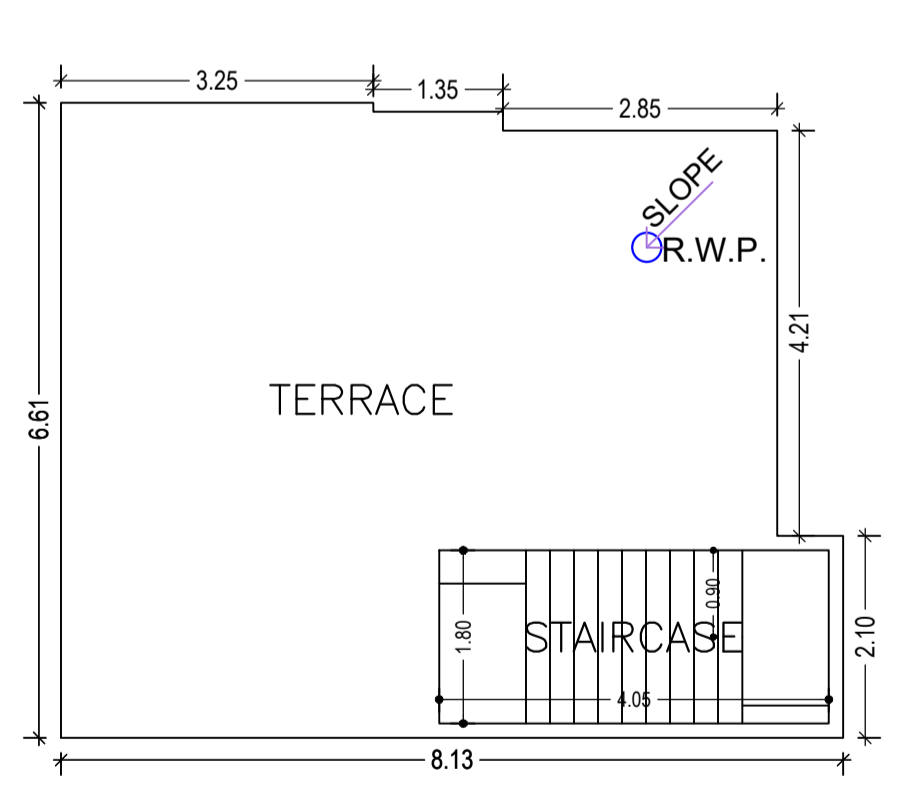

TERRACE FLOOR PLAN (SCALE 1:100)

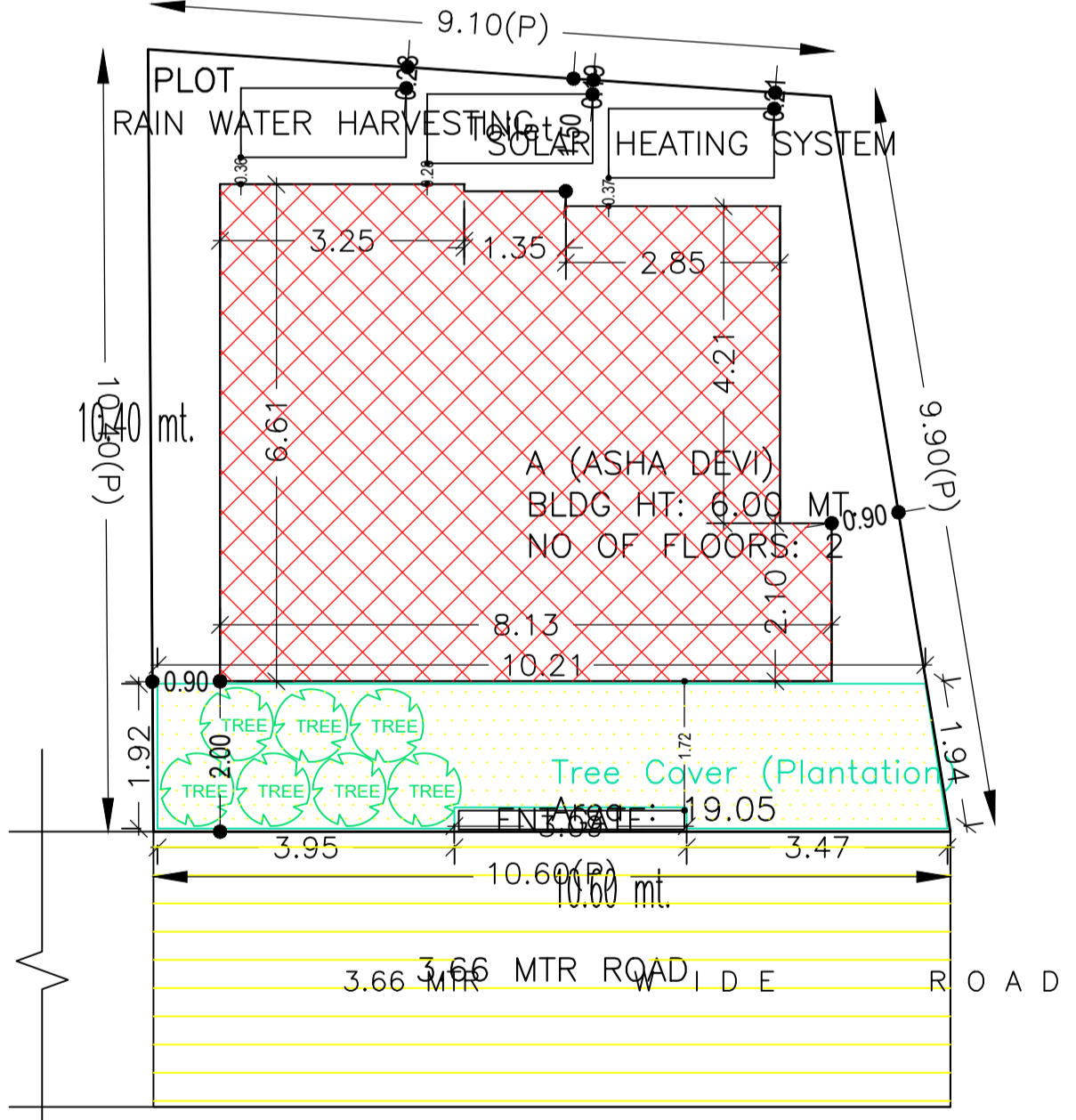

SITE PLAN

AREA STATEMENT CHAS MUNICIPAL CORPORATION		VERSION NO. 1.0.60
PROJECT DETAIL:		VERSION DATE: 16/10/2020
Region: JHARKHAND URBAN LOCAL BODIES	Plot Use: Residential	
District: BOKARO	Plot SubUse: Bungalow/ Dwelling / Non Apartment	
Authority: CHAS MUNICIPAL CORPORATION	PlotNearby/ReligiousStructure: NA	
Inward_No: CMC/BP/0196/W07/2021	PlotSubPlot No: 3801	
Application Type: General Proposal	North: Plot No. - PART & PARCEL OF PLOT	
Project Type: Building Permission	South: Plot No. - 3784	
Nature of Development: New	East: Plot No. - 3800	
Location of Development Area: Old Area	West: Road Width - 3.66	
AREA DETAILS:		SQ. MT.
AREA OF PLOT (Minimum)	(A)	98.97
NET AREA OF PLOT(Gross Plot Area - Deduction from Gross Plot area)	(A-Deductions)	98.97
Deduction for Balance Plot Area(from Gross Plot Area)		
Common Plot		19.05
Total		19.05
BALANCE AREA OF PLOT(Net Plot Area - Recreational/Amenity space)	(A-Deductions)	79.92
PLOT AREA FOR COVERAGE(Net Plot Area)	(A-Deductions)	98.97
Plot Area for FAR (Net Plot Area + Road Widening Area)	(A-Deductions)	98.97
COVERAGE CHECK		
Permissible Coverage area (70.00 %)		69.28
Proposed Coverage Area (50.20 %)		49.68
Total Prop. Coverage Area (50.2 %)		49.68
Balance coverage area (19.80 %)		19.60
FAR CHECK		
Perm. FAR Area (1.50)		148.46
Total Perm. FAR area		148.46
Residential FAR		99.35
Proposed FAR Area		99.35
Total Proposed FAR Area		99.35
Consumed FAR (Factor)		1.00
Balance FAR Area		49.11
BUILT UP AREA CHECK		
Total Proposed BuiltUp Area		99.36
ARCHITECT (Regd)	Manish Agarwal	
ENGINEER (Regd)		
SUPERVISOR (Regd)		
OWNER (Regd)	ASHA DEVI	
DEVELOPMENT AUTHORITY		LOCAL BODY

SCHEDULE OF DOOR:

BUILDING NAME	NAME	LENGTH	HEIGHT	NOS
A (ASHA DEVI)	D1	0.90	2.10	08

SCHEDULE OF WINDOW/VENTILATION:

BUILDING NAME	NAME	LENGTH	HEIGHT	NOS
A (ASHA DEVI)	V	0.60	1.20	02
A (ASHA DEVI)	W2	1.00	1.20	04
A (ASHA DEVI)	W1	1.20	1.20	10

COLOR INDEX

PLOT BOUNDARY	Black
ABUTTING ROAD	Red
PROPOSED CONSTRUCTION	Green
COMMON PLOT	Yellow
ROAD WIDENING AREA	Blue
EXISTING (To be retained)	Orange
EXISTING (To be demolished)	Purple

FAR & Tenement Details (Table 4c-1)

Building	No. of Same Bldg	Total Built Up Area (Sq.mt.)	Proposed FAR Area (Sq.mt.) Resi.	Total FAR Area (Sq.mt.)	Total Consumed Additional FAR Area (Sq.mt.)	Tnmt (No.)
A (ASHA DEVI)	1	99.36	99.36	99.36	99.36	01
Grand Total :	1	99.36	99.36	99.36	99.36	01

Building USE/SUBUSE Details

Building Name	Building Use	Building SubUse	Building Structure
A (ASHA DEVI)	Residential	Bungalow/ Dwelling / Non Apartment	Non-Highrise

UnitBUA Table for Building :A (ASHA DEVI)

FLOOR	Name	UnitBUA Type	UnitBUA Area	Carpet Area	No. of Rooms	No. of Tenement
GROUND FLOOR PLAN	SPLIT ASHA DEVI	FLAT	76.11	75.18	4	1
FIRST FLOOR PLAN	SPLIT ASHA DEVI	FLAT	0.00	0.00	4	0
Total:	-	-	76.11	75.18	8	1

Building :A (ASHA DEVI)

Floor Name	Total Built Up Area (Sq.mt.)	Proposed FAR Area (Sq.mt.) Resi.	Total FAR Area (Sq.mt.)	Total Consumed Additional FAR Area (Sq.mt.)	Tnmt (No.)
Ground Floor	49.68	49.68	49.68	49.68	01
First Floor	49.68	49.68	49.68	49.68	00
Terrace Floor	0.00	0.00	0.00	0.00	00
Total :	99.36	99.36	99.36	99.36	01
Total Number of Same Buildings :	1				
Total :	99.36	99.36	99.36	99.36	01

Buildingwise Floor FAR Details

Floor Name	Building Name A (ASHA DEVI)		Total	
	Proposed Built Up Area (Sq.mt.)	Proposed FAR Area (Sq.mt.)	Total Proposed Built Up Area (Sq.mt.)	Total FAR Area (Sq.mt.)
Ground Floor	49.68	49.68	49.68	49.68
First Floor	49.68	49.68	49.68	49.68
Terrace Floor	0.00	0.00	0.00	0.00
Total :	99.36	99.36	99.36	99.36

LTP NAME AND SIGNATURE	STRUCTURAL ENG'S NAME AND SIGNATURE	BUILDER NAME AND SIGNATURE	DIGITAL SIGNATURE
Manish Agarwal CMC/ARC/0003/2018			