

Project Title :SMT. SHEELA DEVI

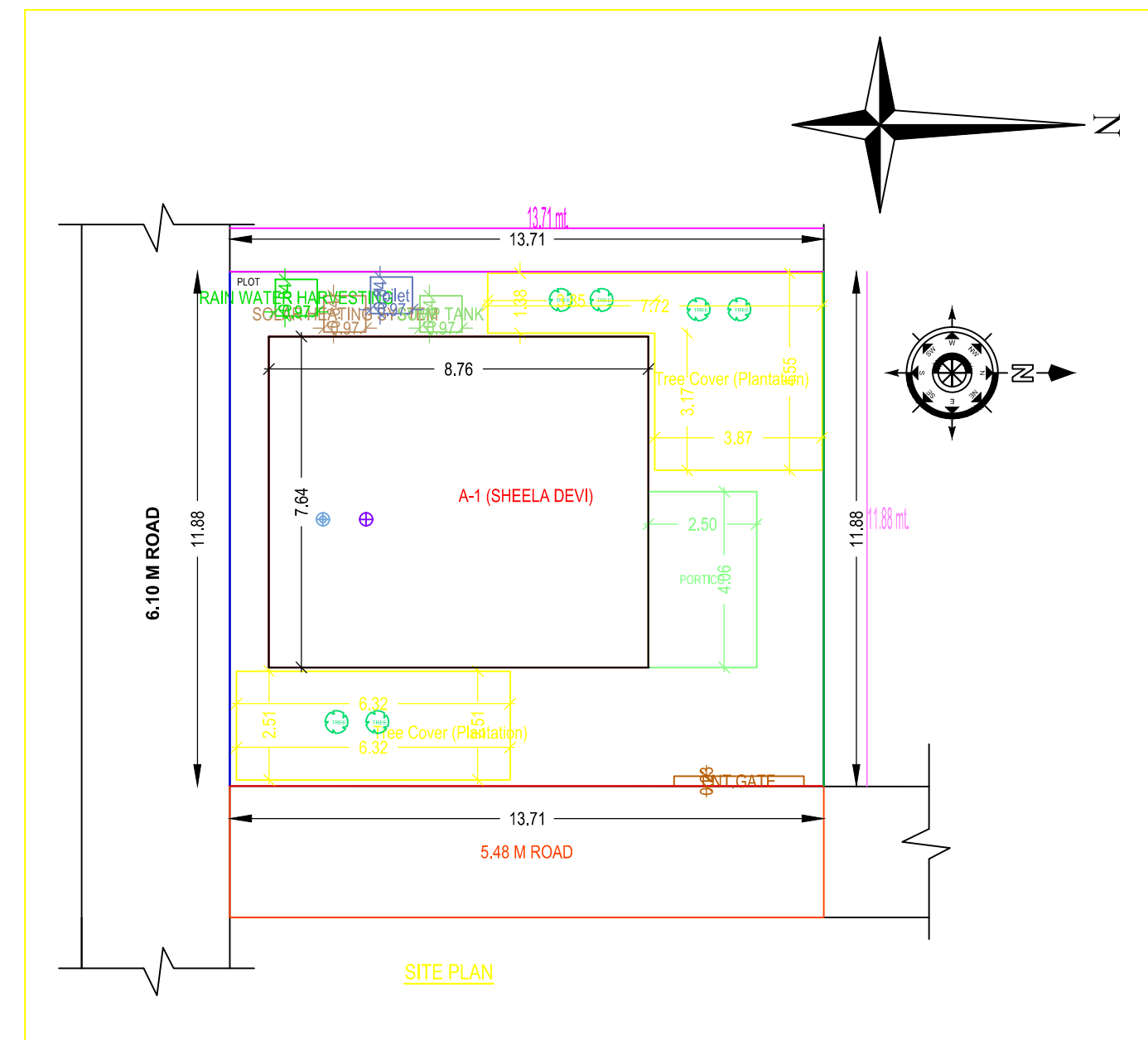
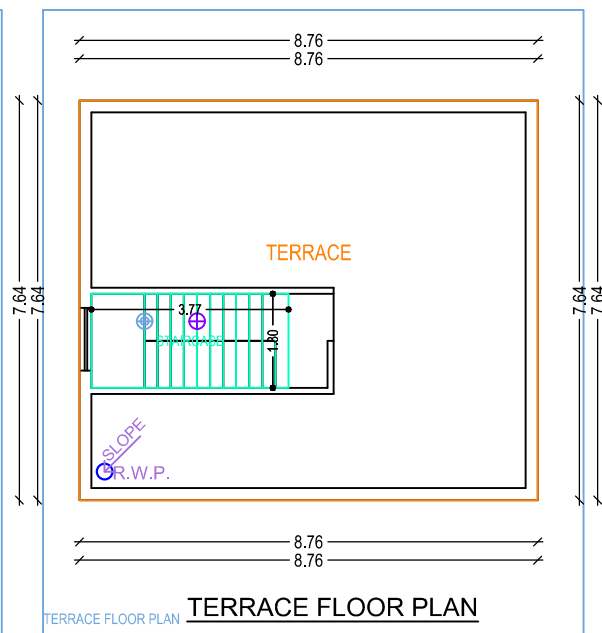
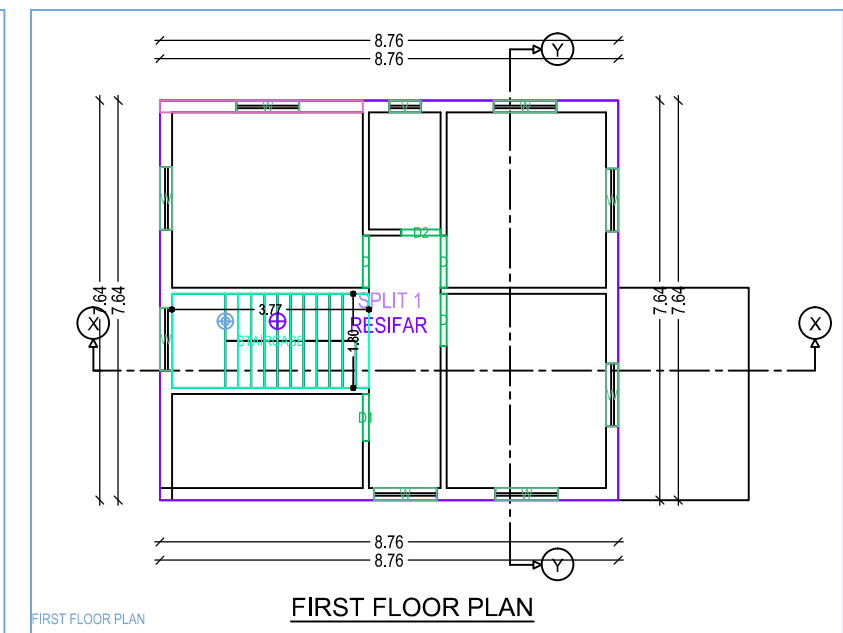
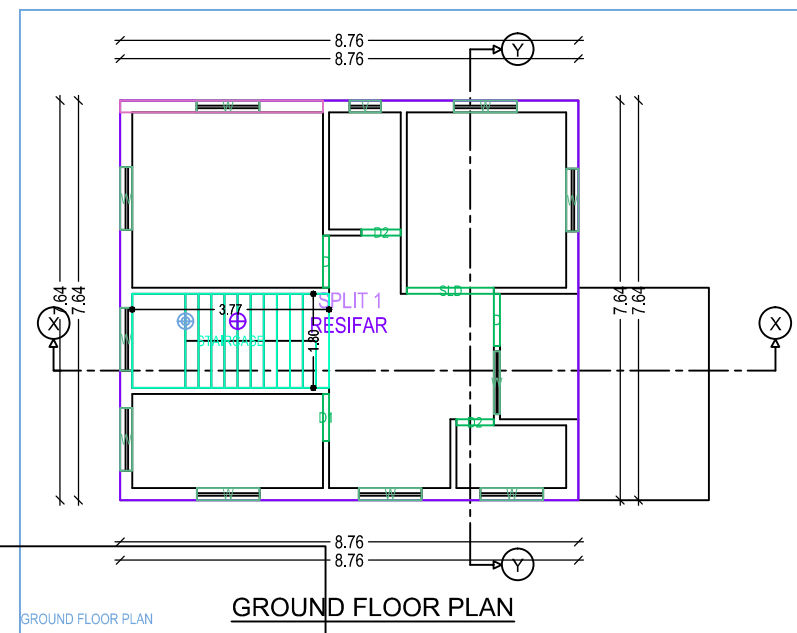
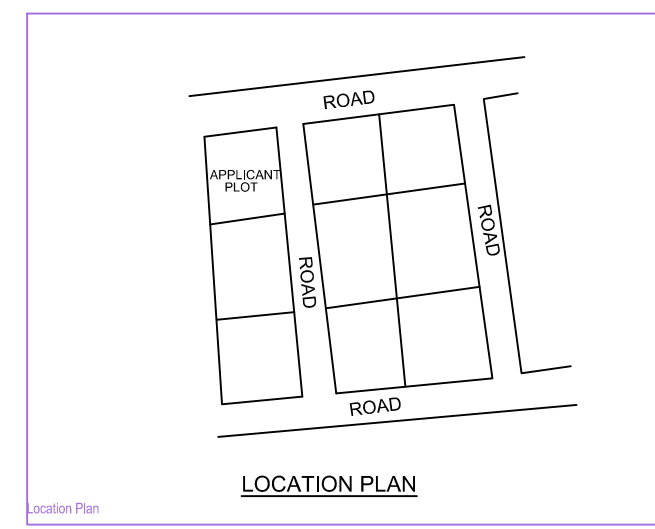
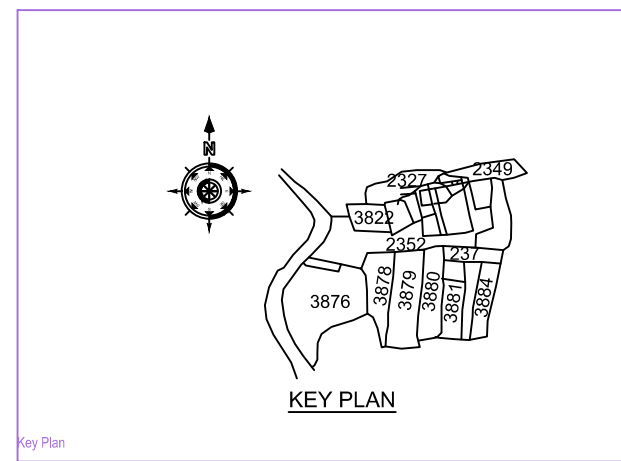
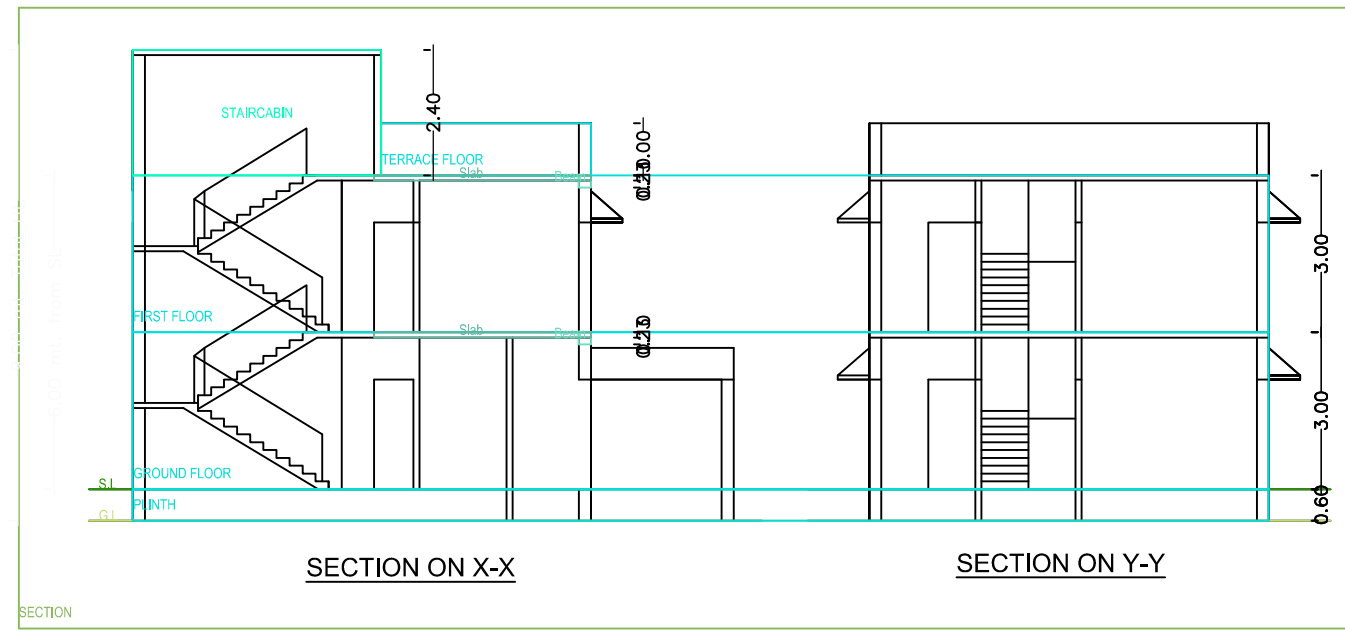
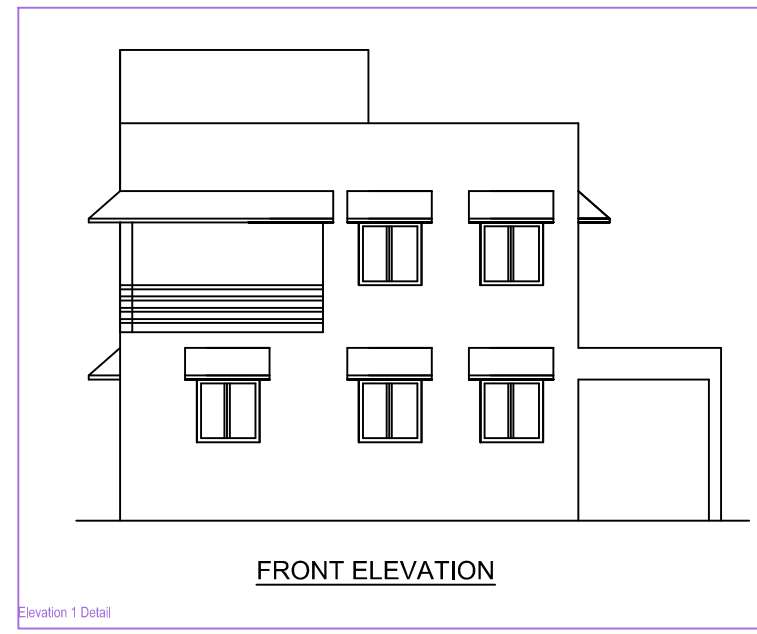
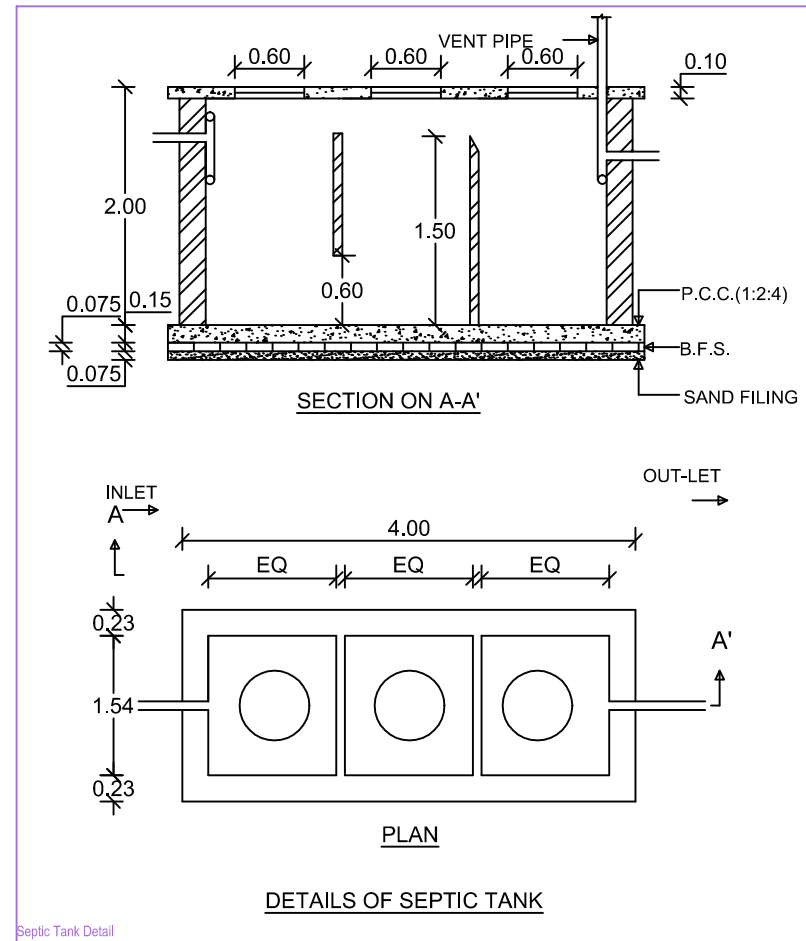
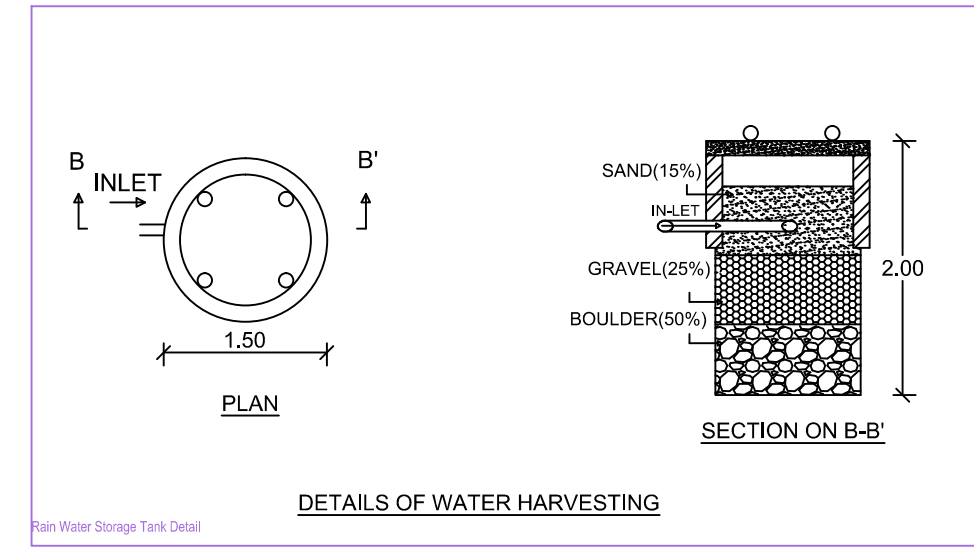
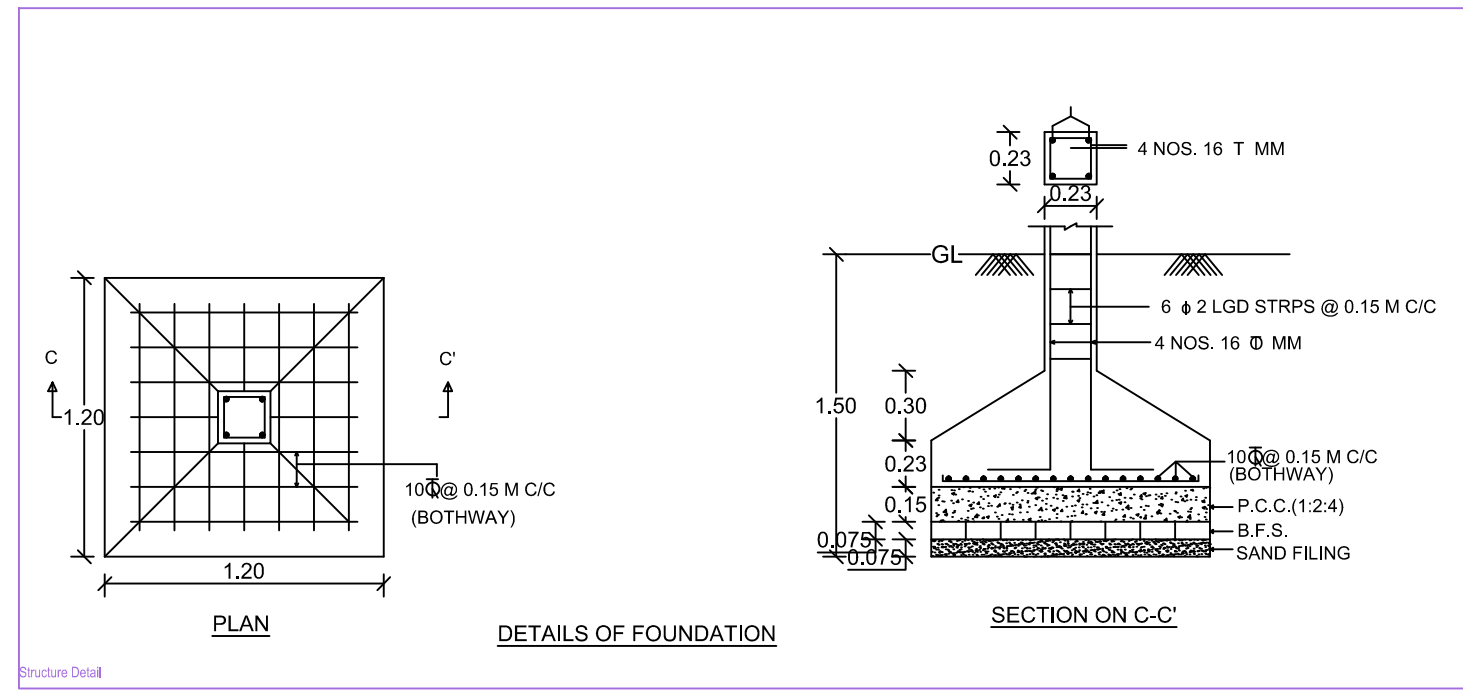

Building 'A' (SHEELA DEVI)

| Floor Name | Total Built Up Area (Sq.m) | Proposed FAR Area (Sq.m) | Total FAR Area (Sq.m) | Trmt (No.) |
|--------------------------------|----------------------------|--------------------------|-----------------------|------------|
| Ground Floor | 66.93 | 66.93 | 66.93 | 01 |
| First Floor | 66.93 | 66.93 | 66.93 | 00 |
| Terrace Floor | 0.00 | 0.00 | 0.00 | 00 |
| Total | 133.86 | 133.86 | 133.86 | 01 |
| Total Number of Same Buildings | 1 | | | |
| Total | 133.86 | 133.86 | 133.86 | 01 |

SCHEDULE OF JOINERY:

| BUILDING NAME | NAME | LENGTH | HEIGHT | NOS |
|-----------------|------|--------|--------|-----------|
| A (SHEELA DEVI) | D2 | 0.71 | 2.10 | 01 |
| A (SHEELA DEVI) | D2 | 0.75 | 2.10 | 02 |
| A (SHEELA DEVI) | D1 | 0.90 | 2.10 | 02 |
| A (SHEELA DEVI) | D | 1.00 | 2.10 | 05 |
| A (SHEELA DEVI) | SLD | 1.66 | 2.10 | 01 |
| Total | - | - | - | 11 |

SCHEDULE OF JOINERY:

| BUILDING NAME | NAME | LENGTH | HEIGHT | NOS |
|-----------------|------|--------|--------|-----------|
| A (SHEELA DEVI) | Y | 0.60 | 1.00 | 02 |
| A (SHEELA DEVI) | W | 1.20 | 1.20 | 16 |
| Total | - | - | - | 20 |

UnitBUA Table for Building 'A' (SHEELA DEVI)

| FLOOR | Name | UnitBUA Type | UnitBUA Area | Carpet Area | No. of Rooms | No. of Tenement |
|-------------------|---------|--------------|---------------|---------------|--------------|-----------------|
| GROUND FLOOR PLAN | SPLIT 1 | FLAT | 133.85 | 132.07 | 8 | 1 |
| Total | - | - | 133.85 | 132.07 | 14 | 1 |

AREA STATEMENT CHAS MUNICIPAL CORPORATION

PROJECT DETAIL:

| | |
|-------------------------------------|---|
| Project No. :- | Plot Use - Residential |
| Region: HAWKHAND URBAN LOCAL BODIES | Plot Sub-Use: Single/Dwelling / Non Apartment |
| District: BOKARO | Land Use Zone: NA |
| Application Type: General Proposal | Abutting Road Width :- |
| Project Type: Building Permission | Plot No. :- |
| Name of Development: New | Revenue Survey No/Survey No. :- |
| Location: 'Old Area | Thana No. :- |
| Sub Location: 'NA | Holding No. :- |
| Village/Moza Name :- | Khasra No. :- |
| Ward No. :- | North :- |
| Road/Street :- | South :- |
| | East :- |
| | West :- |

AREA DETAILS:

| | | | |
|--|----------------|------------|---------------|
| AREA OF PLOT (Minimum) | (A) | SQ.MT. | 162.87 |
| Net Area (Gross Plot Area - Deductions from Gross Plot Area) | (A-Deductions) | | 162.87 |
| Deductions for Balance Plot Area (from Gross Plot Area) | | | 38.77 |
| Total | | | 124.10 |
| Balance Plot Area (Net Plot Area - Recreational/Open Space) | (A-Deductions) | | 124.10 |
| Plot Area for Coverage (Net Plot Area) | (A-Deductions) | | 162.87 |
| Plot Area for FSI (Net Plot Area + Road/Widening Area) | (A-Deductions) | | 162.87 |
| Accessory Area | | | 10.97 |
| COVERAGE CHECK: | | | |
| Proposed Coverage Area (41.09 %) | | | 66.93 |
| Total Coverage Area (41.09 %) | | | 66.93 |
| FAR CHECK: | | | |
| Proposed Area of FAR | | | 133.86 |
| Total Area of FAR | | | 133.86 |
| SOIL TOP ROSE CHECK: | | | |
| Total Proposed Built-up Area | | | 133.86 |
| ARCHT ENGRG / SUPERVISOR (Regd) | | OWNER | |
| DEVELOPMENT AUTHORITY | | LOCAL BODY | |

COLOR INDEX

| | |
|-------------------------------|--|
| Plot Boundary | |
| Abutting Road | |
| Proposed Work (Coverage Area) | |
| Existing (To be retained) | |
| Existing (To be demolished) | |

MARGIN DETAIL:

| Building / Wing Name | Road Name | Rear Margin | Sid1 Margin | Sid2 Margin |
|----------------------|-------------|-------------|-------------|-------------|
| A-1 (SHEELA DEVI) | 5.48 M ROAD | 2.74 | 1.50 | 0.90 |

FAR & Tenement Details (Table 4c-1)

| Building | No. of Same Bldg | Total Built Up Area (Sq.m) | Proposed FAR Area (Sq.m) | Total FAR Area (Sq.m) | Trmt (No.) |
|--------------------|------------------|----------------------------|--------------------------|-----------------------|------------|
| A (SHEELA DEVI) | 1 | 133.86 | 133.86 | 133.86 | 01 |
| Grand Total | 1 | 133.86 | 133.86 | 133.86 | 01 |