

Proposal Basic Information

Proposal File No.	CMC/BP/0110/W07/2021
Owner Name	GULAB DEVI
Khata No	774
Plot No	3596,3599
Village Name	Chas
Use	Residential
SubUse	Bungalow/ Dwelling / Non Apartment

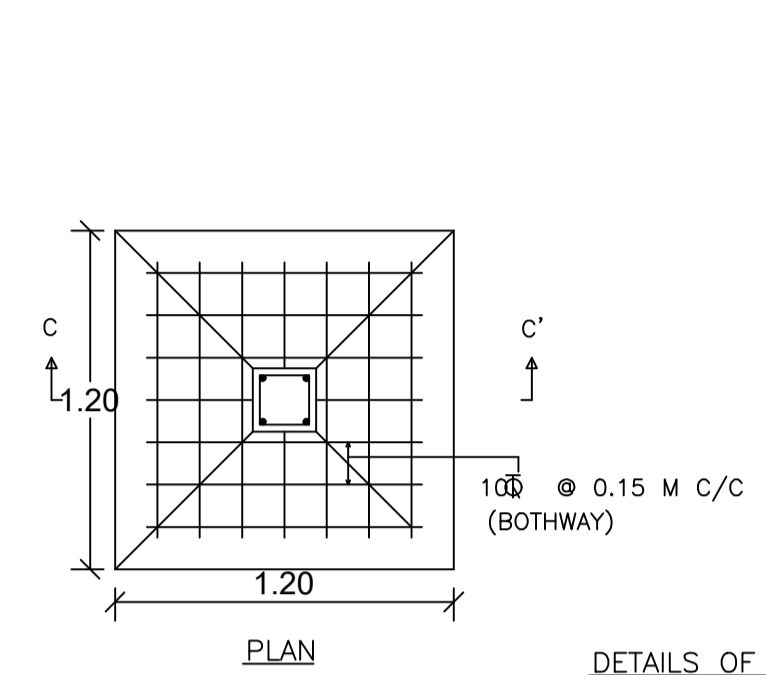

DETAILS OF FOUNDATION

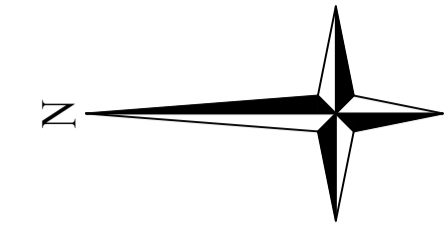
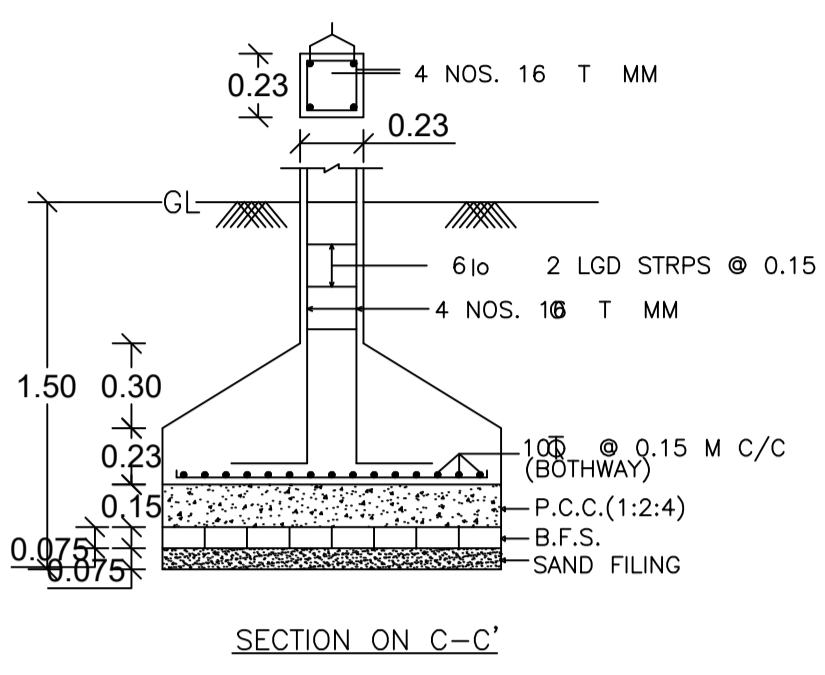

SECTION ON C-C'

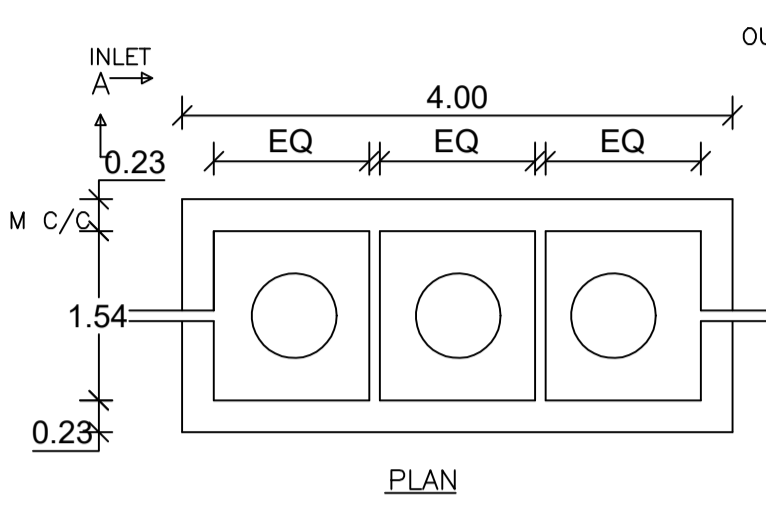

PLAN

DETAILS OF SEPTIC TANK

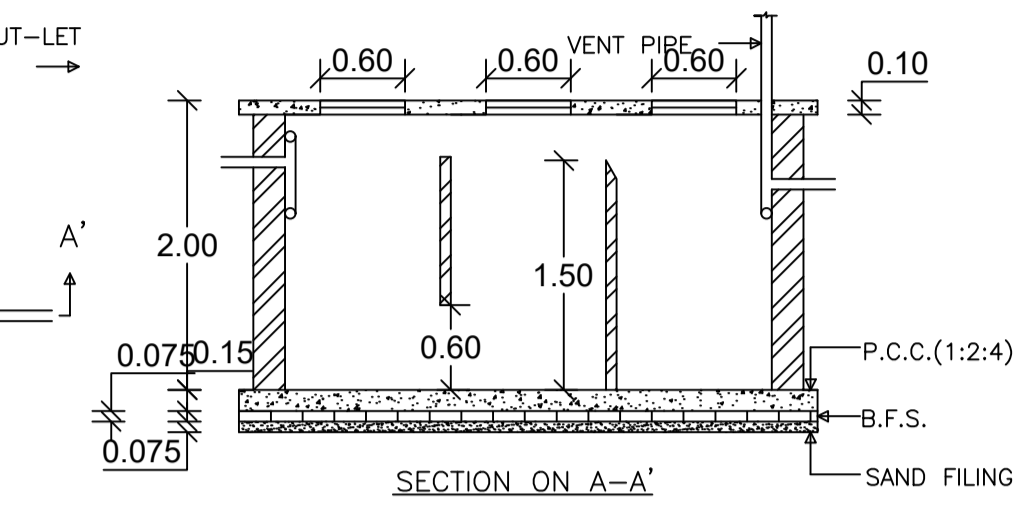

SECTION ON A-A'

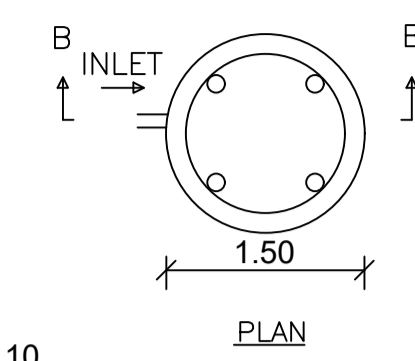

PLAN

DETAILS OF WATER HARVESTING

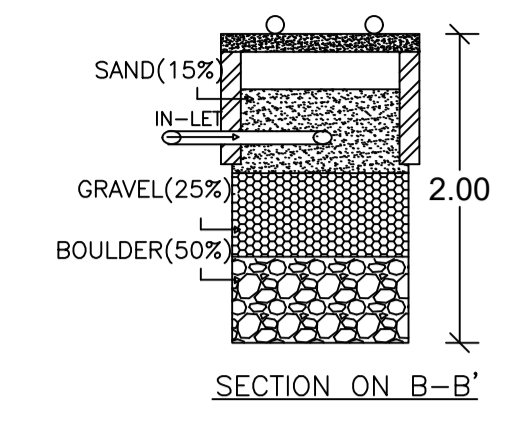

SECTION ON B-B'

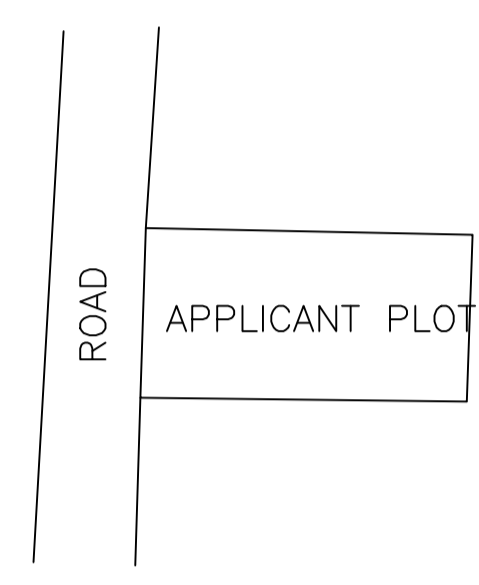

LOCATION PLAN

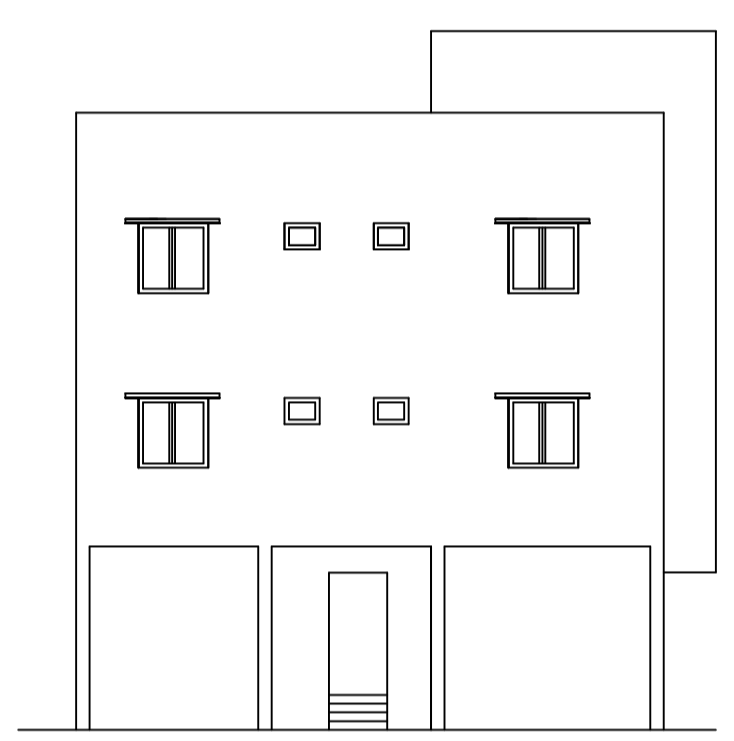

FRONT ELEVATION

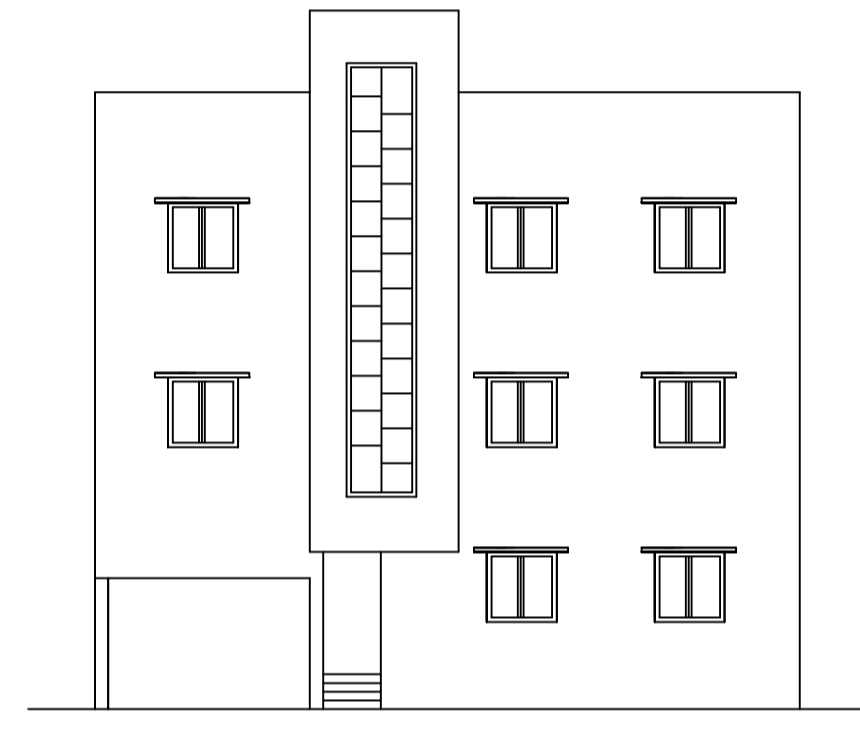

RIGHT SIDE ELEVATION

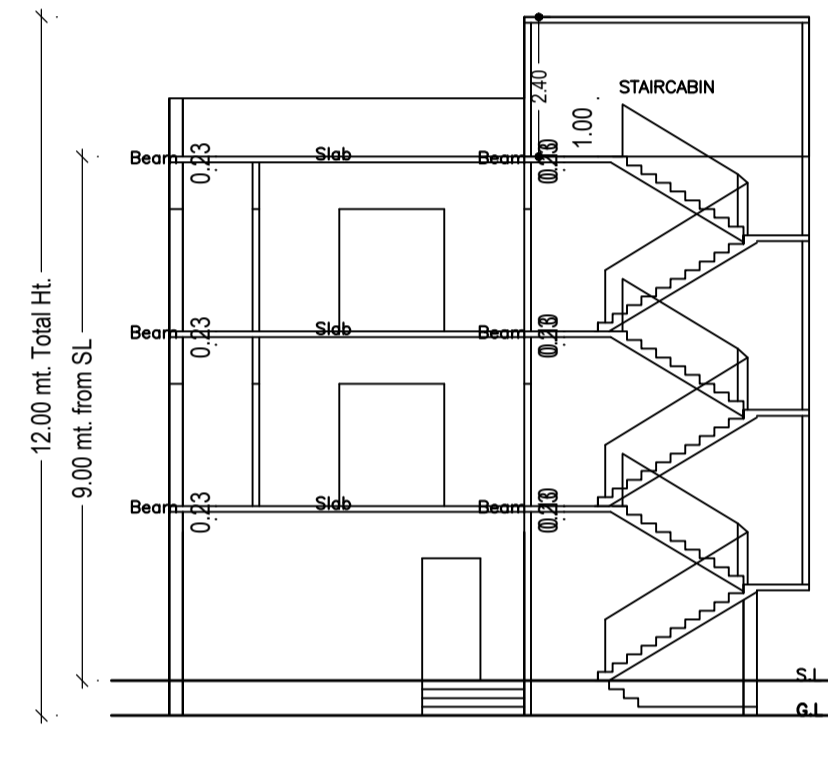

SECTION ON X-X

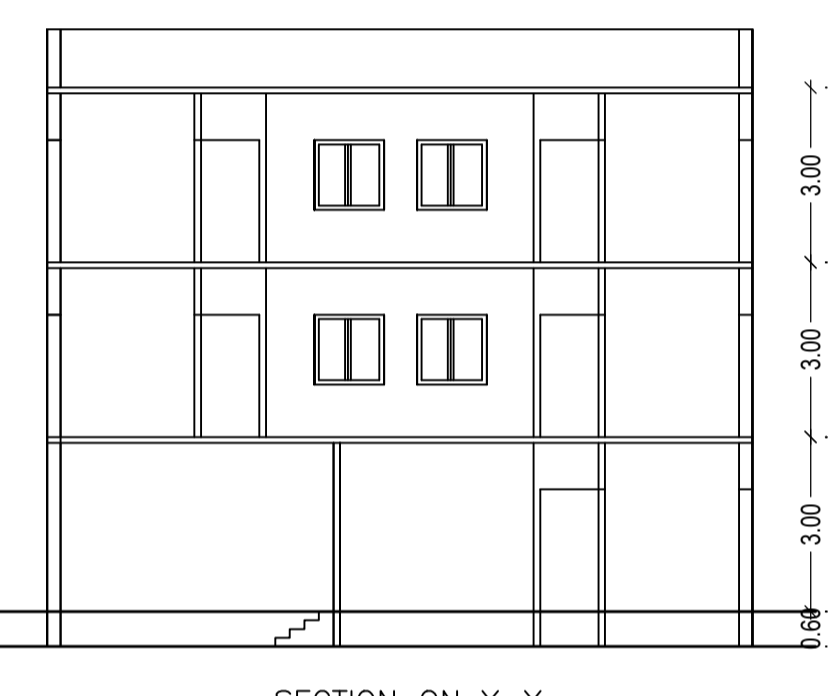

SECTION ON Y-Y

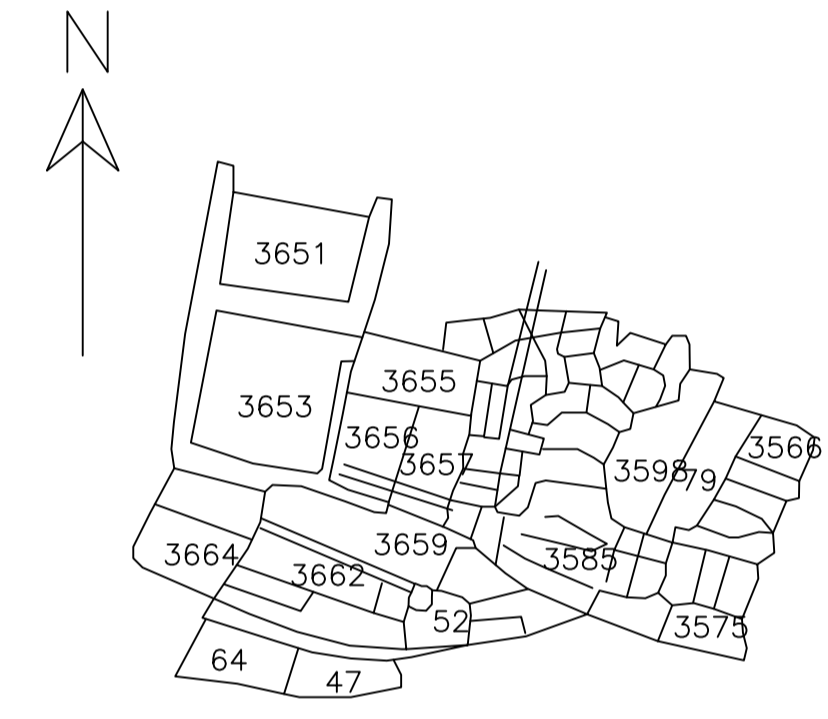

KEY PLAN

AREA STATEMENT CHAS MUNICIPAL CORPORATION	VERSION NO: 1.0.55	SQ. MT.
PROJECT DETAIL:	VERSION DATE: 16/10/2020	
Region: JHARKHAND URBAN LOCAL BODIES	Plot Use: Residential	
District: BOKARO	Plot SubUse: Bungalow/ Dwelling / Non Apartment	
Authority: CHAS MUNICIPAL CORPORATION	PlotNearby/ReligiousStructure: NA	
Inward No: CMC/BP/0110/W07/2021	PlotSubPlot No: 3596,3599	
Application Type: General Proposal	North: Plot No. - K/17 MARK PLOT	
Project Type: Building Permission	South: Plot No. - K/13 MARK PLOT	
Nature of Development: New	East: Plot No. - K/16 MARK PLOT	
Location of Development Area: Old Area	West: Road Width - 5.48 M ROAD	
AREA DETAILS:		
AREA OF PLOT (Minimum)	(A)	222.74
NET AREA OF PLOT(Gross Plot Area - Deduction from Gross Plot area)	(A-Deductions)	222.74
Deduction for Balance Plot Area(from Gross Plot Area)		
Common Plot		24.84
Total		24.84
BALANCE AREA OF PLOT(Net Plot Area - Recreational/Amenity space)	(A-Deductions)	197.89
PLOT AREA FOR COVERAGE(Net Plot Area)	(A-Deductions)	222.74
Plot Area for FAR (Net Plot Area + Road Widening Area)	(A-Deductions)	222.74
COVERAGE CHECK		
Permissible Coverage area (70.00 %)		155.92
Proposed Coverage Area (54.88 %)		122.24
Total Prop. Coverage Area (54.88 %)		122.24
Balance coverage area (15.12 %)		33.68
FAR CHECK		
Perm. FAR Area (1.80)		400.93
Total Perm. FAR area		400.93
Residential FAR		366.71
Proposed FAR Area		366.71
Total Proposed FAR Area		366.71
Consumed FAR (Factor)		1.65
Balance FAR Area		34.22
BUILT UP AREA CHECK		
Total Proposed BuiltUp Area		366.72
ARCHITECT (Regd)	Suresh Prasad Singh	
ENGINEER (Regd)		
SUPERVISOR (Regd)		
OWNER (Regd)	GULAB DEVI	
DEVELOPMENT AUTHORITY LOCAL BODY		

Buildingwise Floor FAR Details

Floor Name	Building Name A (GULAB DEVI)		Total	
	Proposed Built Up Area (Sq.mt.)	Proposed FAR Area (Sq.mt.)	Total Proposed Built Up Area (Sq.mt.)	Total FAR Area (Sq.mt.)
Ground Floor	122.24	122.24	122.24	122.24
First Floor	122.24	122.24	122.24	122.24
Second Floor	122.24	122.24	122.24	122.24
Terrace Floor	0.00	0.00	0.00	0.00
Total :	366.72	366.72	366.72	366.72

Building :A (GULAB DEVI)

Floor Name	Total Built Up Area (Sq.mt.)	Proposed FAR Area (Sq.mt.)	Total FAR Area (Sq.mt.)	Total Consumed Additional FAR Area (Sq.mt.)	Tnmt (No.)
Ground Floor	122.24	122.24	122.24	122.24	01
First Floor	122.24	122.24	122.24	122.24	00
Second Floor	122.24	122.24	122.24	122.24	00
Terrace Floor	0.00	0.00	0.00	0.00	00
Total :	366.72	366.72	366.72	366.72	01
Total Number of Same Buildings	1				
Total :	366.72	366.72	366.72	366.72	01

SCHEDULE OF DOOR:

BUILDING NAME	NAME	LENGTH	HEIGHT	NOS
A (GULAB DEVI)	D2	0.75	2.10	10
A (GULAB DEVI)	D1	0.90	2.10	03
A (GULAB DEVI)	D	1.00	2.10	14

SCHEDULE OF WINDOW/VENTILATION:

BUILDING NAME	NAME	LENGTH	HEIGHT	NOS
A (GULAB DEVI)	V	0.60	1.20	10
A (GULAB DEVI)	W	1.20	1.20	27

Building USE/SUBUSE Details

Building Name	Building Use	Building SubUse	Building Structure
A (GULAB DEVI)	Residential	Bungalow/ Dwelling / Non Apartment	Non-Highrise

UnitBUA Table for Building :A (GULAB DEVI)

FLOOR	Name	UnitBUA Type	UnitBUA Area	Carpet Area	No. of Rooms	No. of Tenement
GROUND FLOOR PLAN	SPLIT 1	FLAT	366.71	364.55	6	1
FIRST FLOOR PLAN	SPLIT 1	FLAT	0.00	0.00	10	0
SECOND FLOOR PLAN	SPLIT 1	FLAT	0.00	0.00	10	0
Total:	-	-	366.71	364.55	26	1

FAR & Tenement Details (Table 4c-1)

Building	No. of Same Bldg	Total Built Up Area (Sq.mt.)	Proposed FAR Area (Sq.mt.)	Total FAR Area (Sq.mt.)	Total Consumed Additional FAR Area (Sq.mt.)	Tnmt (No.)
A (GULAB DEVI)	1	366.72	366.72	366.72	366.72	01
Grand Total :	1	366.72	366.72	366.72	366.72	01

COLOR INDEX

PLOT BOUNDARY	Black
ABUTTING ROAD	Red
PROPOSED CONSTRUCTION	Green
COMMON PLOT	Blue
ROAD WIDENING AREA	Yellow
EXISTING (To be retained)	Orange
EXISTING (To be demolished)	Purple

LTP NAME AND SIGNATURE

Suresh Prasad Singh	STRUCTURAL ENG'S NAME AND SIGNATURE	BUILDER NAME AND SIGNATURE	DIGITAL SIGNATURE
CMC/ENG/0002/2017			