

Proposal Basic Information	
Proposal File No.	CMC/BP/0164/W07/2021
Owner Name	MAMTA VERMA
Khata No.	41
Plot No.	203,205
Village Name	Bhawanipur
Use	Residential
SubUse	Bungalow/ Dwelling / Non Apartment

AREA STATEMENT CHAS MUNICIPAL CORPORATION		VERSION NO. - 1.0.60
PROJECT DETAIL:		VERSION DATE: 16/10/2020
Region: JHARKHAND URBAN LOCAL BODIES	Plot Use: Residential	
District: BOKARO	Plot SubUse: Bungalow/ Dwelling / Non Apartment	
Authority: CHAS MUNICIPAL CORPORATION	PlotNearbyReligiousStructure: NA	
Inward No: CMC/BP/0164/W07/2021	PlotSubPlot No: 203,205	
Application Type: General Proposal	North: Plot No. - 208	
Project Type: Building Permission	South: Road Width - 3.96 M ROAD	
Nature of Development: New	East: Plot No. - PART OF PLOT	
Location of Development Area: Old Area	West: Plot No. - RUBI DEVI	
AREA DETAILS:		
AREA OF PLOT (Minimum)	(A)	SQ.MT. 121.40
NET AREA OF PLOT(Gross Plot Area - Deduction from Gross Plot area)	(A-Deductions)	121.40
Deduction for Balance Plot Area(from Gross Plot Area)		
Common Plot		10.98
Total		10.98
BALANCE AREA OF PLOT(Net Plot Area - Recreational/Amenity space)	(A-Deductions)	110.42
PLOT AREA FOR COVERAGE(Net Plot Area)	(A-Deductions)	121.40
Plot Area for FAR (Net Plot Area + Road/Widening Area)	(A-Deductions)	121.40
COVERAGE CHECK		
Permissible Coverage area (70.00 %)		84.98
Proposed Coverage Area (59.10 %)		71.75
Total Prop. Coverage Area (59.1 %)		71.75
Balance coverage area (10.90 %)		13.23
FAR CHECK		
Perm. FAR Area (1.50)		182.10
Total Perm. FAR area		182.10
Residential FAR		143.50
Proposed FAR Area		143.50
Total Proposed FAR Area		143.50
Consumed FAR (Factor)		1.18
Balance FAR Area		38.60
BUILT UP AREA CHECK		
Total Proposed BuiltUp Area		143.50
ARCHITECT (Regd)		RAVI KUMAR
ENGINEER (Regd)		
SUPERVISOR (Regd)		
OWNER (Regd)		MAMTA VERMA
DEVELOPMENT AUTHORITY		LOCAL BODY

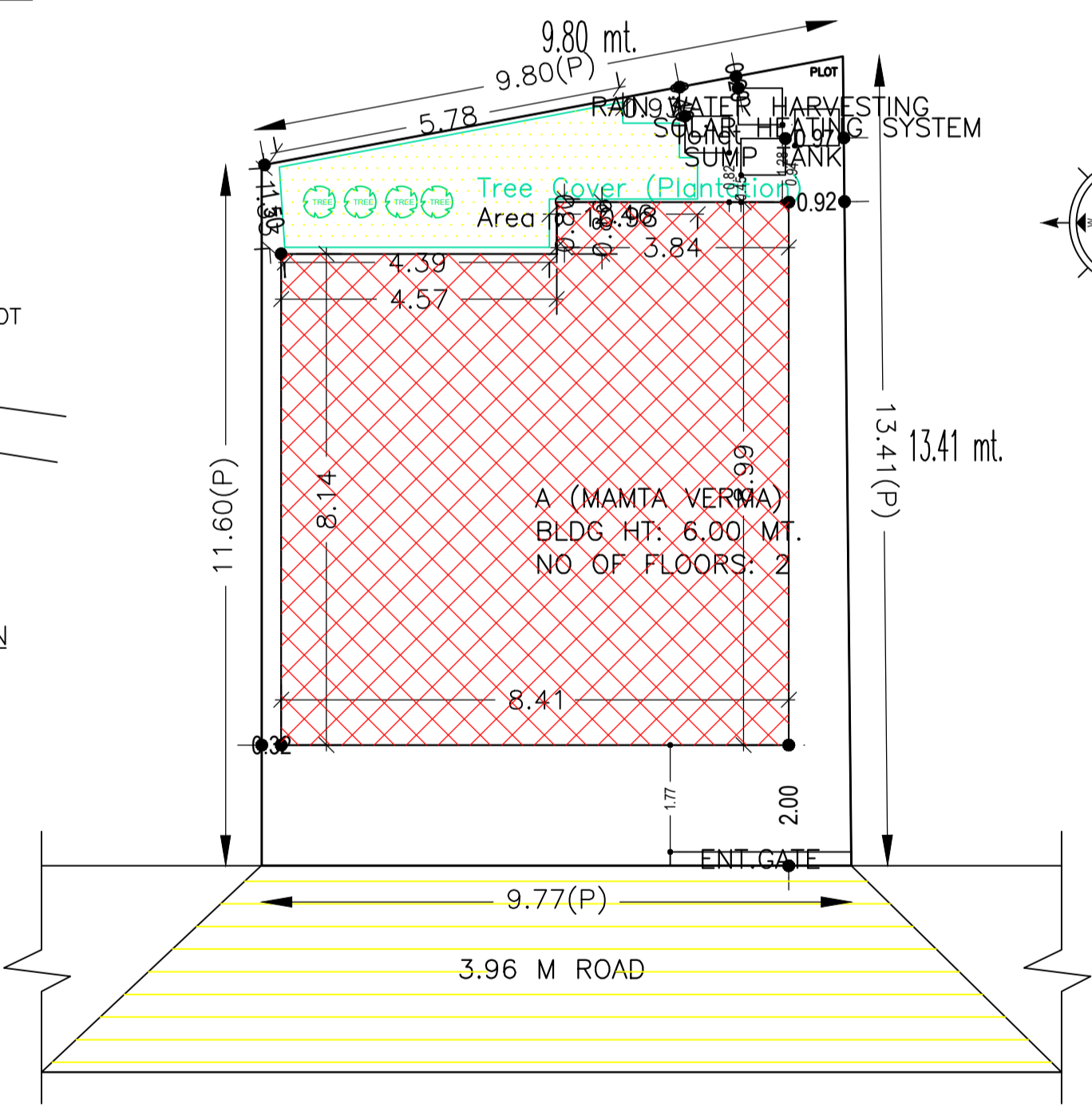
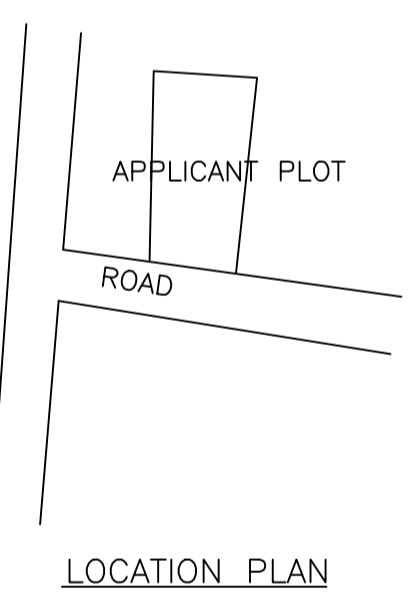
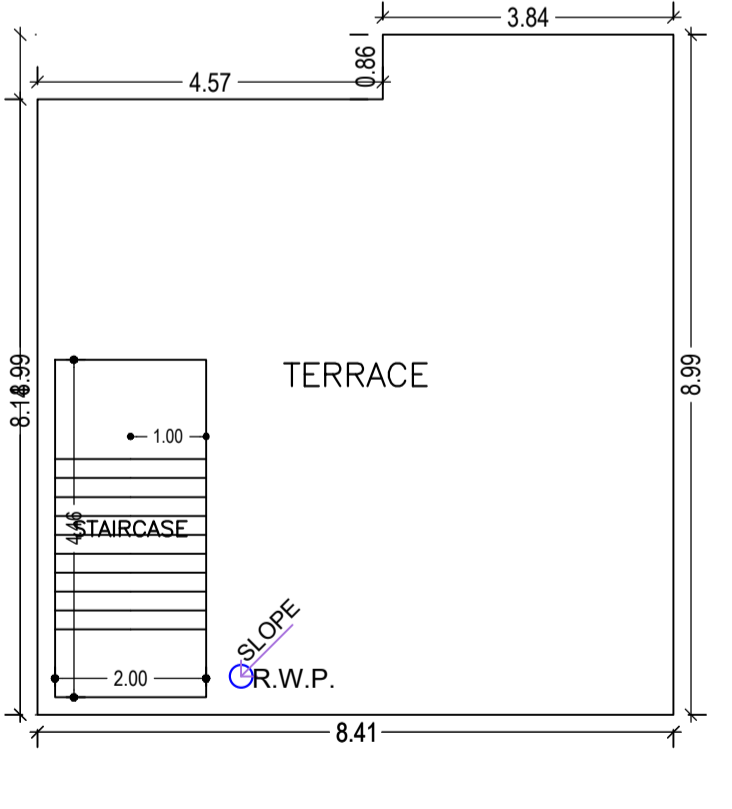
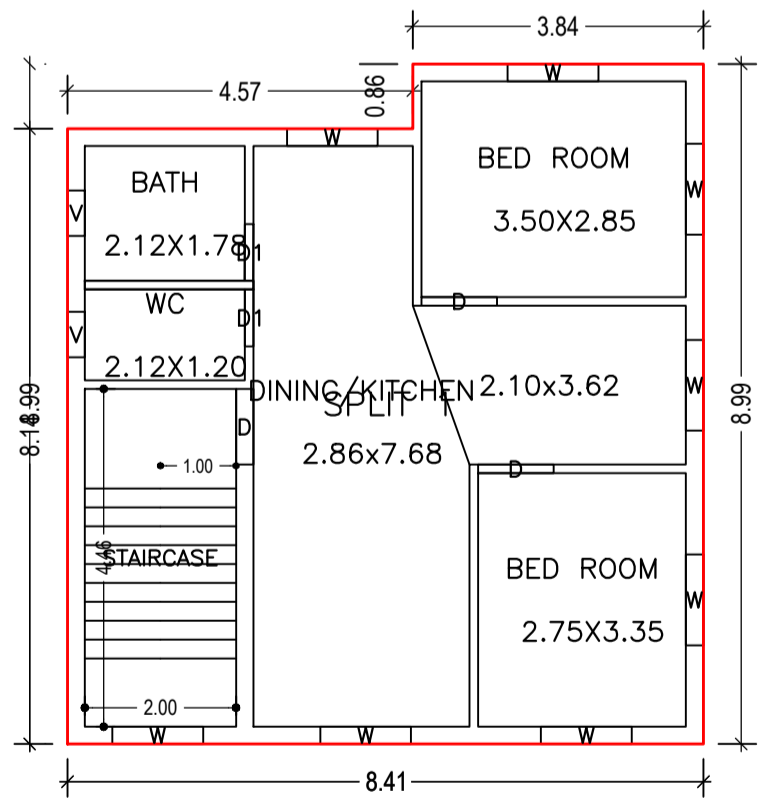
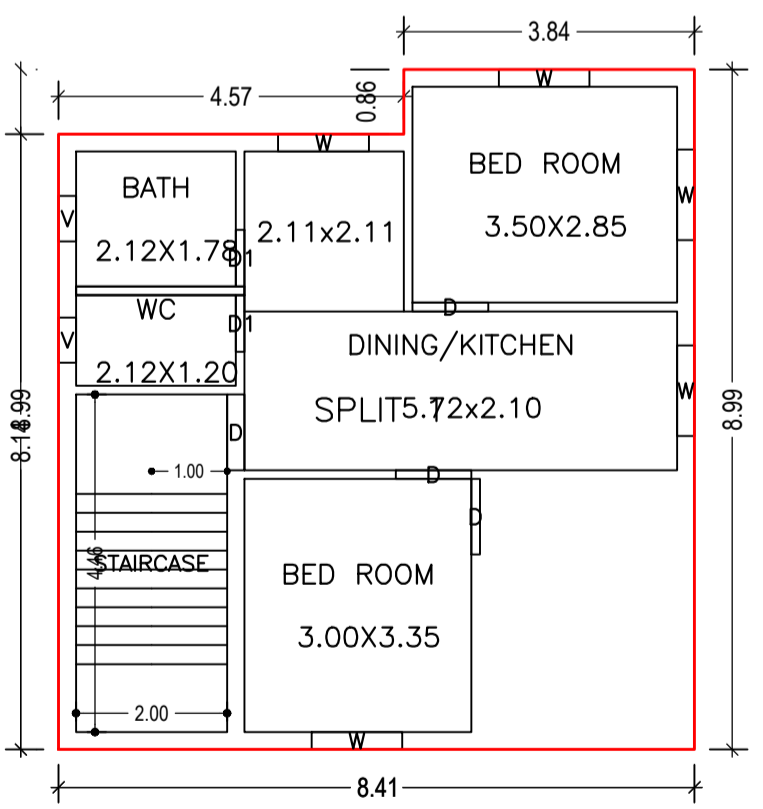
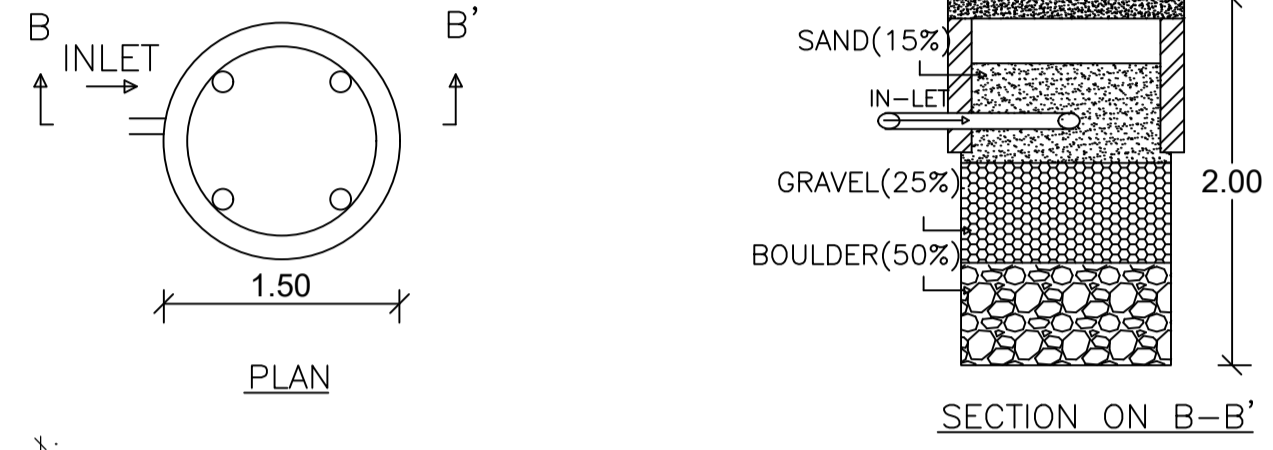
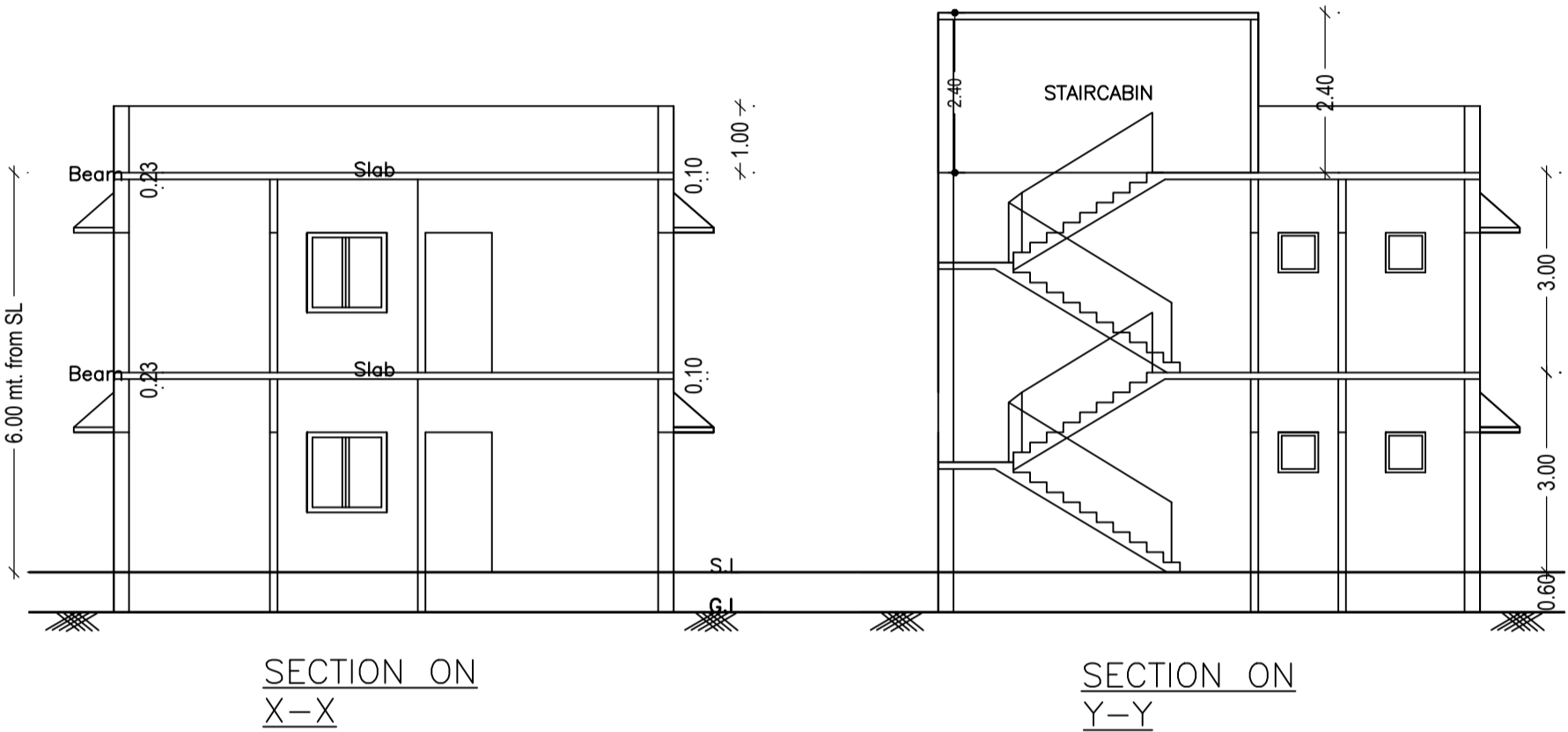

Building :A (MAMTA VERMA)					
Floor Name	Total Built Up Area (Sq.mt.)	Proposed FAR Area (Sq.mt.) Resi.	Total FAR Area (Sq.mt.)	Total Consumed Additional FAR Area (Sq.mt.)	Trmt (No.)
Ground Floor	71.75	71.75	71.75	71.75	01
First Floor	71.75	71.75	71.75	71.75	00
Terrace Floor	0.00	0.00	0.00	0.00	00
Total :	143.50	143.50	143.50	143.50	01
Total Number of Same Buildings	1				
Total :	143.50	143.50	143.50	143.50	01

SCHEDULE OF DOOR:					
BUILDING NAME	NAME	LENGTH	HEIGHT	NOS	
A (MAMTA VERMA)	D1	0.75	2.10	04	
A (MAMTA VERMA)	D	1.00	2.10	07	

SCHEDULE OF WINDOW/VENTILATION:					
BUILDING NAME	NAME	LENGTH	HEIGHT	NOS	
A (MAMTA VERMA)	V	0.60	1.20	04	
A (MAMTA VERMA)	W	1.20	1.20	13	

UnitBUA Table for Building :A (MAMTA VERMA)						
FLOOR	Name	UnitBUA Type	UnitBUA Area	Carpet Area	No. of Rooms	No. of Tenement
GROUND FLOOR PLAN	SPLIT 1	FLAT	143.50	142.98	5	1
FIRST FLOOR PLAN	SPLIT 1	FLAT	0.00	0.00	5	0
Total:	-	-	143.50	142.98	10	1

FAR & Tenement Details (Table 4c-1)						
Building	No. of Same Bldg	Total Built Up Area (Sq.mt.)	Proposed FAR Area (Sq.mt.) Resi.	Total FAR Area (Sq.mt.)	Total Consumed Additional FAR Area (Sq.mt.)	Trmt (No.)
A (MAMTA VERMA)	1	143.50	143.50	143.50	143.50	01
Grand Total :	1	143.50	143.50	143.50	143.50	01

Buildingwise Floor FAR Details				
Floor Name	Building Name A (MAMTA VERMA)		Total	
	Proposed Built Up Area (Sq.mt.)	Proposed FAR Area (Sq.mt.)	Total Proposed Built Up Area (Sq.mt.)	Total FAR Area (Sq.mt.)
Ground Floor	71.75	71.75	71.75	71.75
First Floor	71.75	71.75	71.75	71.75
Terrace Floor	0.00	0.00	0.00	0.00
Total :	143.50	143.50	143.50	143.50

Building USE/SUBUSE Details			
Building Name	Building Use	Building SubUse	Building Structure
A (MAMTA VERMA)	Residential	Bungalow/ Dwelling / Non Apartment	Non-Highrise

COLOR INDEX	
PLOT BOUNDARY	Black
ABUTTING ROAD	Red
PROPOSED CONSTRUCTION	Green
COMMON PLOT	Blue
ROAD WIDENING AREA	Yellow
EXISTING (To be retained)	White
EXISTING (To be demolished)	Grey

LTP NAME AND SIGNATURE	STRUCTURAL ENG'S NAME AND SIGNATURE	BUILDER NAME AND SIGNATURE	DIGITAL SIGNATURE
RAVI KUMAR CMC/DFTMN/0024/2017			