

Proposal Basic Information

Proposal File No.	CMC/BP/0053/W07/2021
Owner Name	Purushottam sharmaGautam kumar sharma
Khata No	656
Plot No	2468
Village Name	Chas
Use	Residential
SubUse	Bungalow/ Dwelling / Non Apartment

AREA STATEMENT CHAS MUNICIPAL CORPORATION	VERSION NO.: 1.0.54	
	VERSION DATE: 16/10/2020	
PROJECT DETAIL:		
Region : JHARKHAND URBAN LOCAL BODIES	Plot Use: Residential	
District: BOKARO	Plot SubUse: Bungalow/ Dwelling / Non Apartment	
Authority: CHAS MUNICIPAL CORPORATION	Plot/Nearby/Religious/Structure: NA	
Inward No: CMC/BP/0053/W07/2021	Plot/SubPlot No: 2468	
Application Type: General Proposal	North: Plot No. - nitu pandey	
Project Type: Building Permission	South: Plot No. - niwaran mahatha	
Nature of Development: New	East: Road Width - 4.57	
Location of Development Area: Old Area	West: Plot No. - jaynarayan mahatha	
AREA DETAILS:		
AREA OF PLOT (Minimum)	(A)	SQ.MT.
NET AREA OF PLOT(Gross Plot Area - Deduction from Gross Plot area)	(A-Deductions)	140.22
Deduction for Balance Plot Area(from Gross Plot Area)		
Common Plot		22.02
Total		22.02
BALANCE AREA OF PLOT(Net Plot Area - Recreational/Amenity space)	(A-Deductions)	118.19
PLOT AREA FOR COVERAGE(Net Plot Area)	(A-Deductions)	140.22
Plot Area for FAR (Net Plot Area + Road/Widening Area)	(A-Deductions)	140.22
COVERAGE CHECK		
Permissible Coverage area (70.00 %)		98.15
Proposed Coverage Area (66.09 %)		92.67
Total Prop. Coverage Area (66.09 %)		92.67
Balance coverage area (3.91 %)		5.48
FAR CHECK		
Perm. FAR Area (1.50)		210.33
Total Perm. FAR area		210.33
Residential FAR		185.35
Proposed FAR Area		185.35
Total Proposed FAR Area		185.35
Consumed FAR (Factor)		1.32
Balance FAR Area		24.98
BUILT UP AREA CHECK		
Total Proposed BuiltUp Area		185.34
ARCHITECT (Regd)	Trilochan Kumar Trivedi	
ENGINEER (Regd)		
SUPERVISOR (Regd)		
OWNER (Regd)	Purushottam sharmaGautam kumar sharma	
DEVELOPMENT AUTHORITY LOCAL BODY		

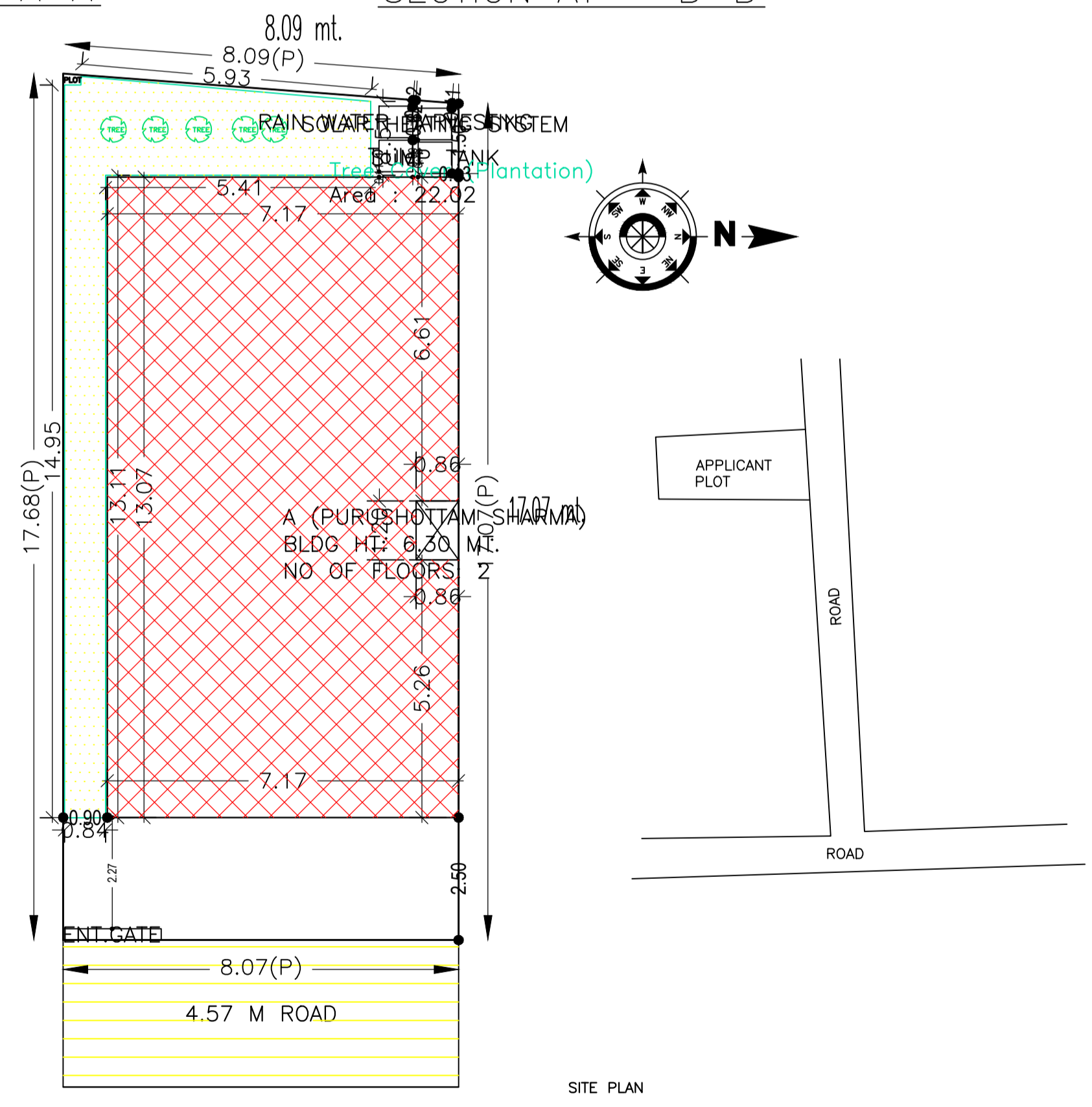
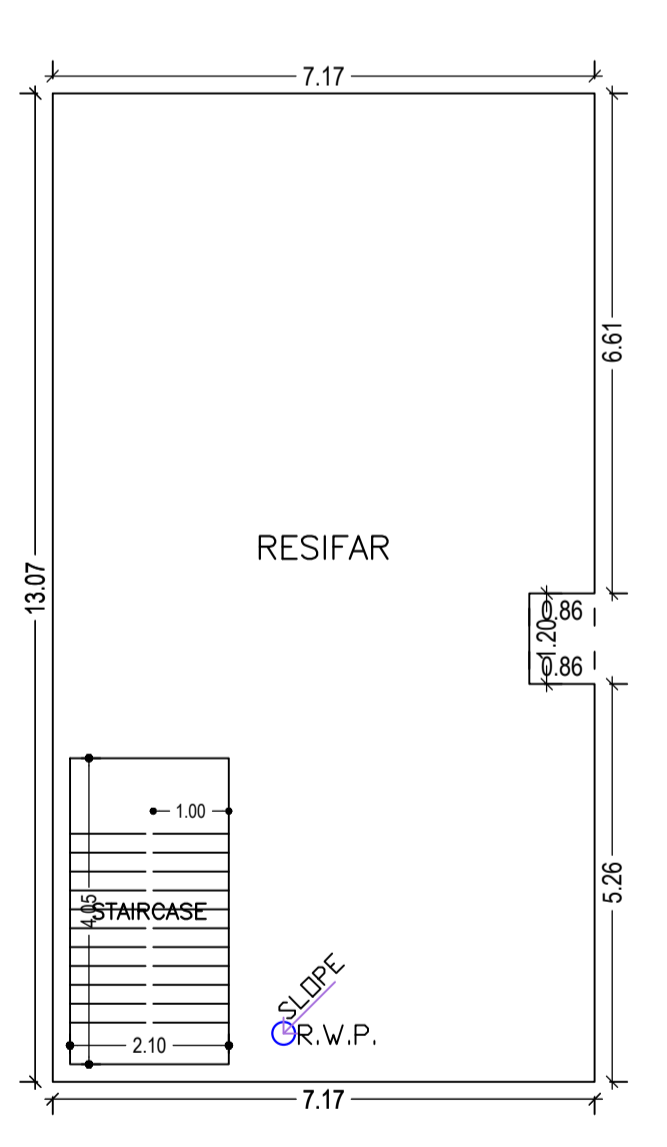
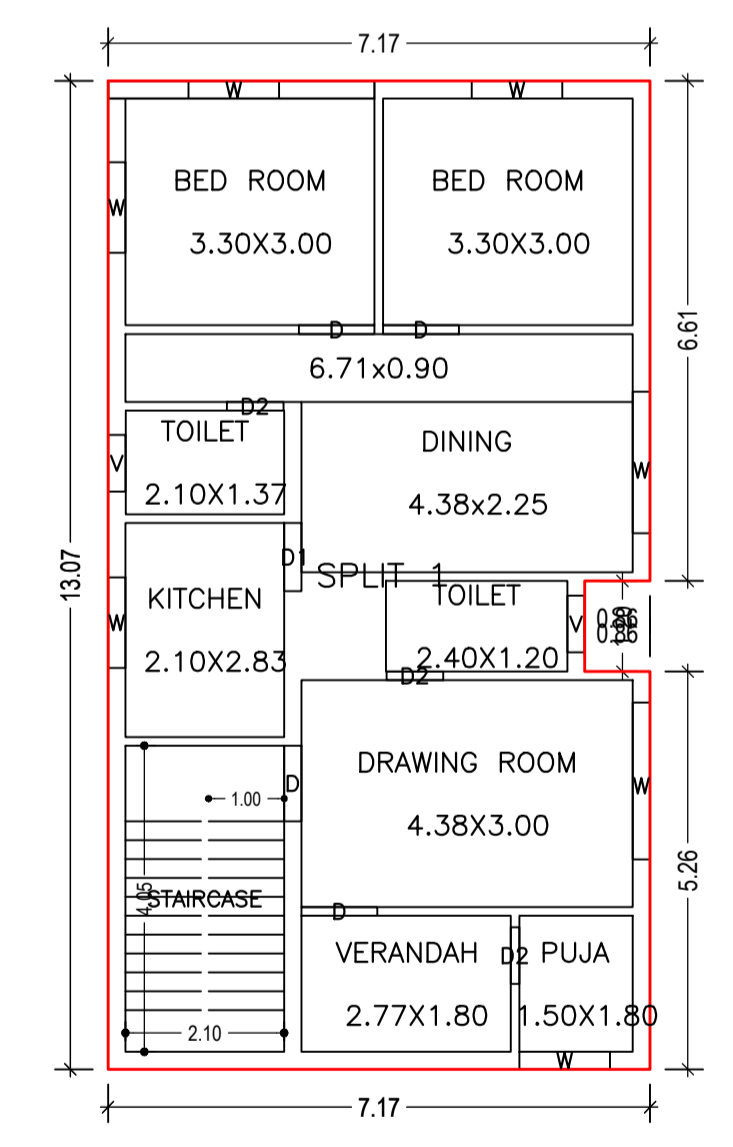
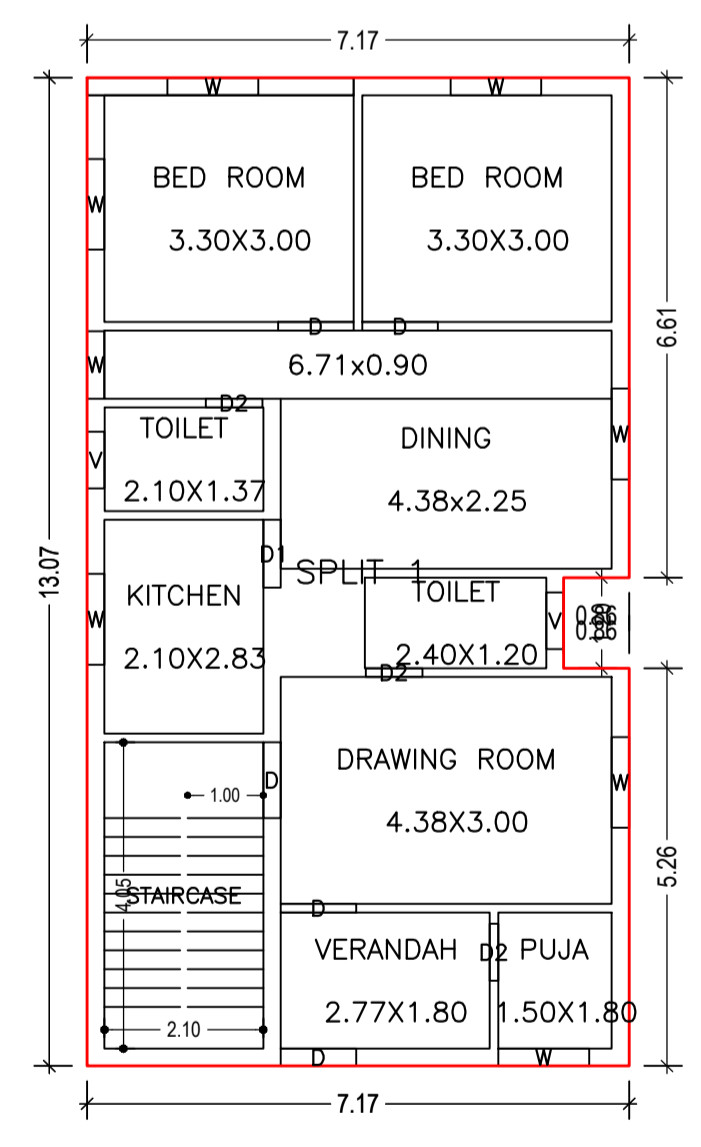
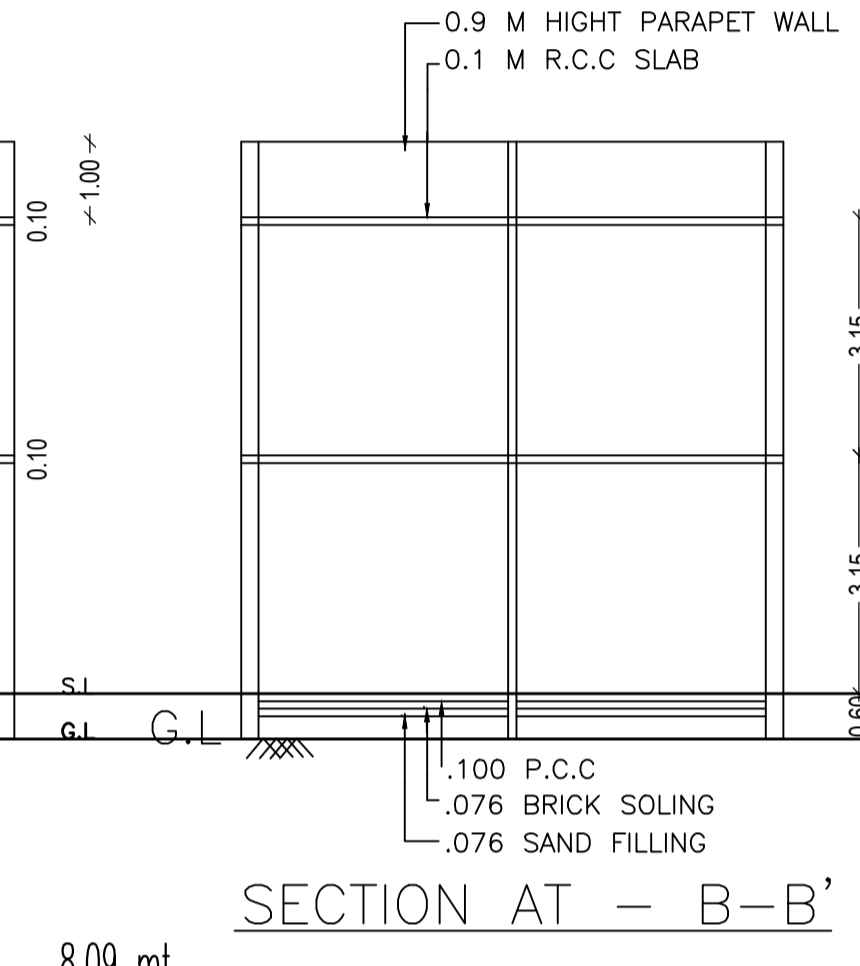
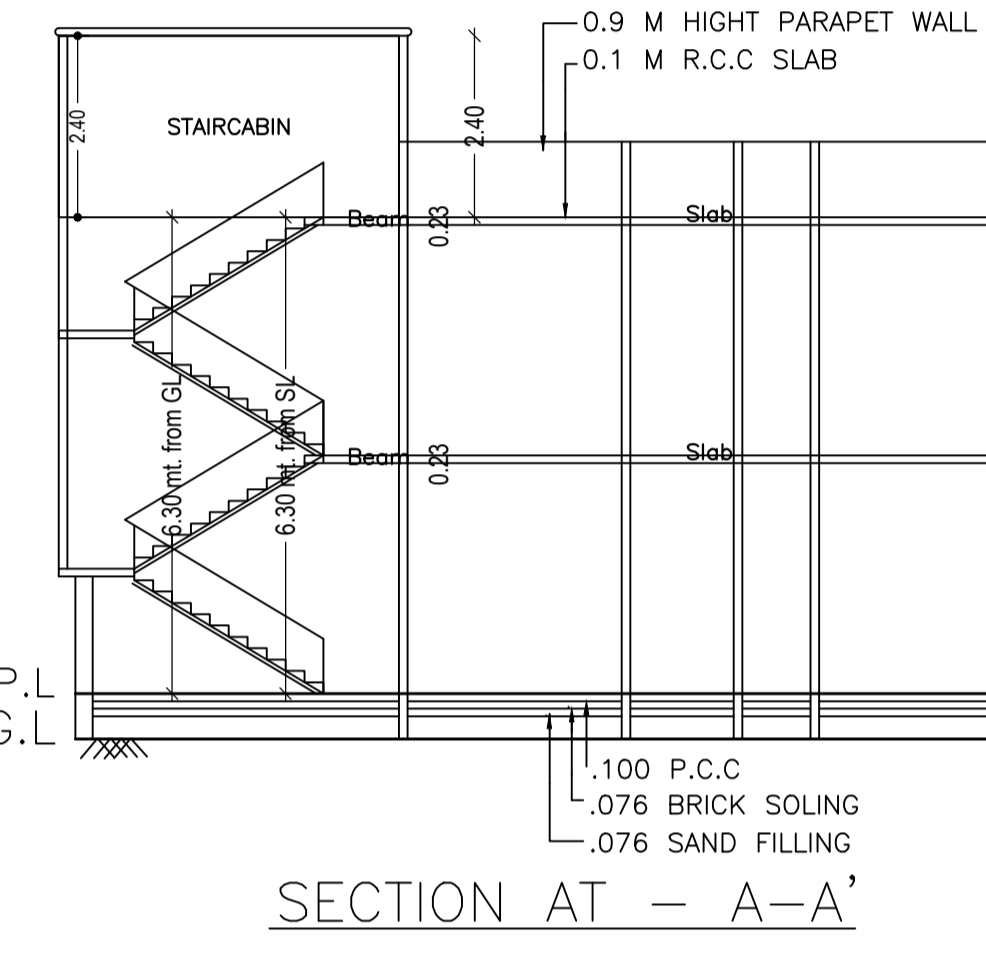
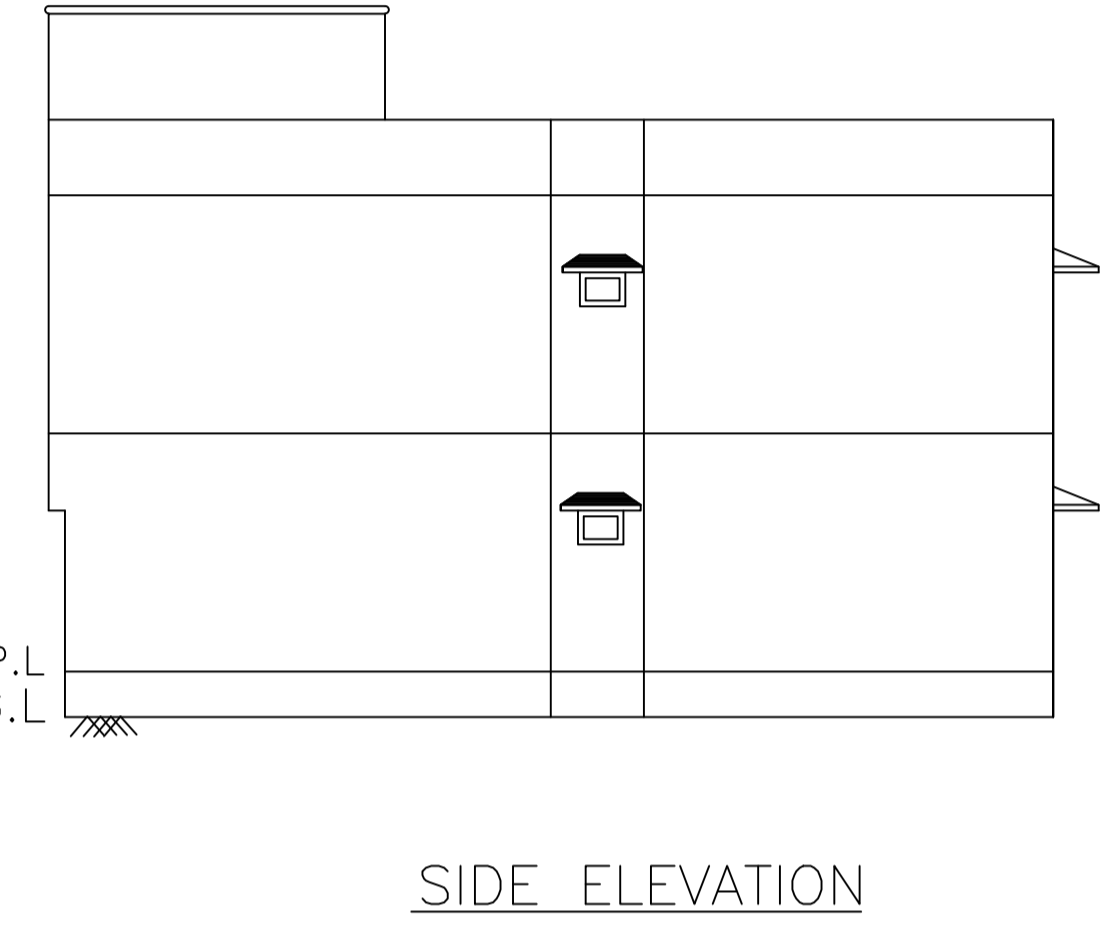
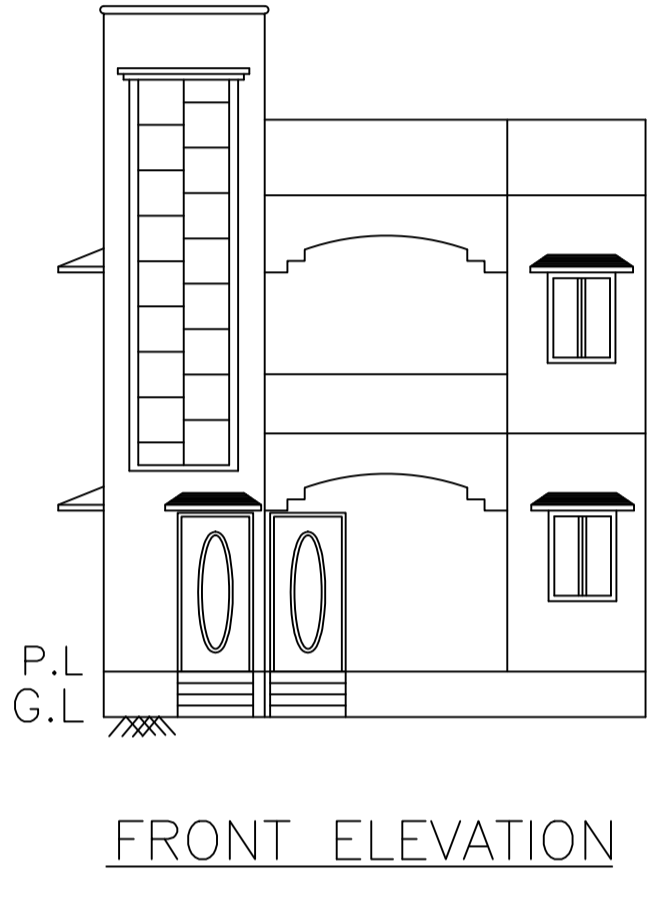

Buildingwise Floor FAR Details

Floor Name	Building Name		Total	
	A (PURUSHOTTAM SHARMA)	Proposed FAR Area (Sq.mt.)	Total Proposed Built Up Area (Sq.mt.)	Total FAR Area (Sq.mt.)
Ground Floor	92.67	92.67	92.67	92.67
First Floor	92.67	92.67	92.67	92.67
Terrace Floor	0.00	0.00	0.00	0.00
Total :	185.34	185.34	185.34	185.34

FAR & Tenement Details (Table 4c-1)

Building	No. of Same Bldg	Total Built Up Area (Sq.mt.)	Proposed FAR Area (Sq.mt.) Resi.	Total FAR Area (Sq.mt.)	Total Consumed Additional FAR Area (Sq.mt.)	Tnmt (No.)
A (PURUSHOTTAM SHARMA)	1	185.34	185.34	185.34	185.34	01
Grand Total :	1	185.34	185.34	185.34	185.34	01

SCHEDULE OF DOOR:

BUILDING NAME	NAME	LENGTH	HEIGHT	NOS
A (PURUSHOTTAM SHARMA)	D2	0.75	2.10	06
A (PURUSHOTTAM SHARMA)	D1	0.90	2.10	02
A (PURUSHOTTAM SHARMA)	D	1.00	2.10	09

SCHEDULE OF WINDOW/VENTILATION:

BUILDING NAME	NAME	LENGTH	HEIGHT	NOS
A (PURUSHOTTAM SHARMA)	V	0.75	1.20	04
A (PURUSHOTTAM SHARMA)	W	0.89	1.20	01
A (PURUSHOTTAM SHARMA)	W	1.20	1.20	12
A (PURUSHOTTAM SHARMA)	W	1.87	1.20	01
A (PURUSHOTTAM SHARMA)	W	2.07	1.20	01

Building :A (PURUSHOTTAM SHARMA)

Floor Name	Total Built Up Area (Sq.mt.)	Proposed FAR Area (Sq.mt.) Resi.	Total FAR Area (Sq.mt.)	Total Consumed Additional FAR Area (Sq.mt.)	Tnmt (No.)
Ground Floor	92.67	92.67	92.67	92.67	01
First Floor	92.67	92.67	92.67	92.67	00
Terrace Floor	0.00	0.00	0.00	0.00	00
Total :	185.34	185.34	185.34	185.34	01

UnitBUA Table for Building :A (PURUSHOTTAM SHARMA)

FLOOR	Name	UnitBUA Type	UnitBUA Area	Carpel Area	No. of Rooms	No. of Tenement
GROUND FLOOR PLAN	SPLIT 1	FLAT	185.35	183.73	9	1
FIRST FLOOR PLAN	SPLIT 1	FLAT	0.00	0.00	9	0
Total:	-	-	185.35	183.73	18	1

Building USE/SUBUSE Details

Building Name	Building Use	Building SubUse	Building Structure
A (PURUSHOTTAM SHARMA)	Residential	Bungalow/ Dwelling / Non Apartment	Non-Highrise

COLOR INDEX

PLOT BOUNDARY	Black
ABUTTING ROAD	Red
PROPOSED CONSTRUCTION	Green
COMMON PLOT	Yellow
ROAD WIDENING AREA	Blue
EXISTING (To be retained)	Orange
EXISTING (To be demolished)	Purple

LTP NAME AND SIGNATURE	STRUCTURAL ENG'S NAME AND SIGNATURE	BUILDER NAME AND SIGNATURE	DIGITAL SIGNATURE
Trilochan Kumar Trivedi CMC/SUP/0003/2017			