

Proposal Basic Information	
Proposal File No.	CMC/BP/0079/W04/2021
Owner Name	NAVEEN KUMAR SAKUJA
Khata No	01
Plot No	1712
Village Name	Chas
Use	Residential
SubUse	Bungalow/ Dwelling / Non Apartment

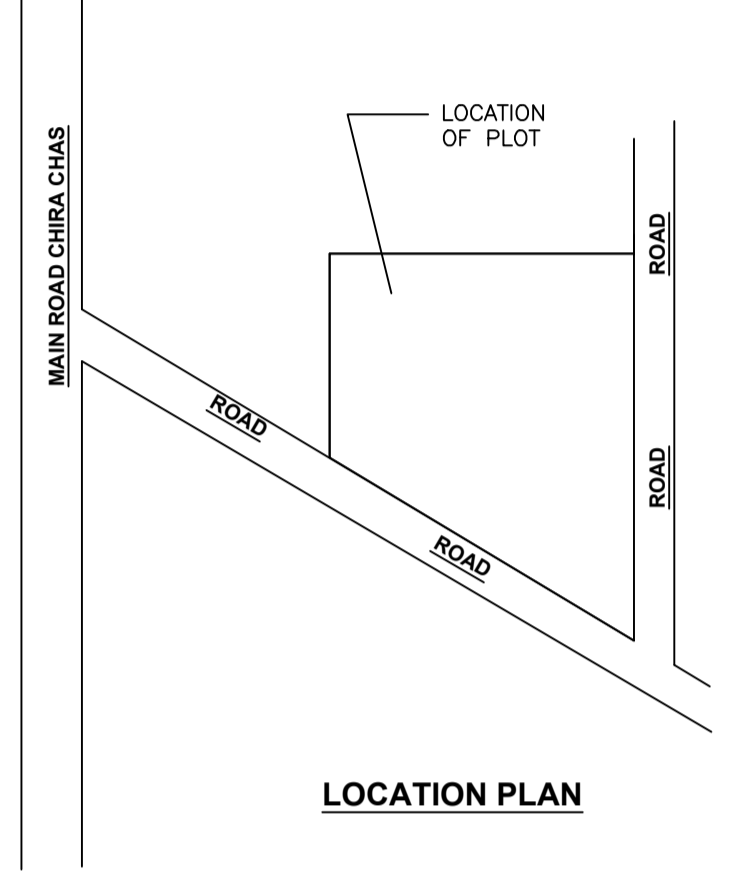

AREA STATEMENT CHAS MUNICIPAL CORPORATION		VERSION NO. : 1.0.55	VERSION DATE: 16/10/2020
PROJECT DETAIL:			
Region: JHARKHAND URBAN LOCAL BODIES	Plot Use: Residential		
District: BOKARO	Plot SubUse: Bungalow/ Dwelling / Non Apartment		
Authority: CHAS MUNICIPAL CORPORATION	PlotNearby/ReligiousStructure: NA		
Inward No: CMC/BP/0079/W04/2021	Plot/SubPlot No: 1712		
Application Type: General Proposal	North: Road Width - 6		
Project Type: Building Permission	South: CTS No. - PLOT NO.-1712		
Nature of Development: New	East: CTS No. - PLOT NO.-1712		
Location of Development Area: New Area	West: Road Width - 3		
AREA DETAILS:			
AREA OF PLOT (Minimum)	(A)		SQ.MT. 414.90
Deduction for NetPlot Area			
Surrender Free of Cost		20.65	
Total		20.65	
NET AREA OF PLOT(Gross Plot Area - Deduction from Gross Plot area)	(A-Deductions)		394.25
Deduction for Balance Plot Area(from Gross Plot Area)			
Surrender Free of Cost		20.65	
Common Plot		157.83	
Total		178.48	
BALANCE AREA OF PLOT(Net Plot Area - Recreational/Amenity space)	(A-Deductions)		236.42
PLOT AREA FOR COVERAGE(Net Plot Area)	(A-Deductions)		394.25
Plot Area for FAR (Net Plot Area + RoadWidening Area)	(A-Deductions)		414.90
COVERAGE CHECK			
Permissible Coverage area (60.00 %)			236.55
Proposed Coverage Area (22.06 %)			86.96
Total Prop. Coverage Area (22.06 %)			86.96
Balance coverage area (37.94 %)			149.59
FAR CHECK			
Perm. FAR Area (1.50)			622.35
Total Perm. FAR area			622.35
Residential FAR			260.88
Proposed FAR Area			260.88
Total Proposed FAR Area			260.88
Consumed FAR (Factor)			0.63
Balance FAR Area			361.47
BUILT UP AREA CHECK			
Total Proposed BuiltUp Area			260.88
ARCHITECT (Regd)		MANOJ KUMAR	
ENGINEER (Regd)			
SUPERVISOR (Regd)			
OWNER (Regd)		NAVEEN KUMAR SAKUJA	
DEVELOPMENT AUTHORITY		LOCAL BODY	

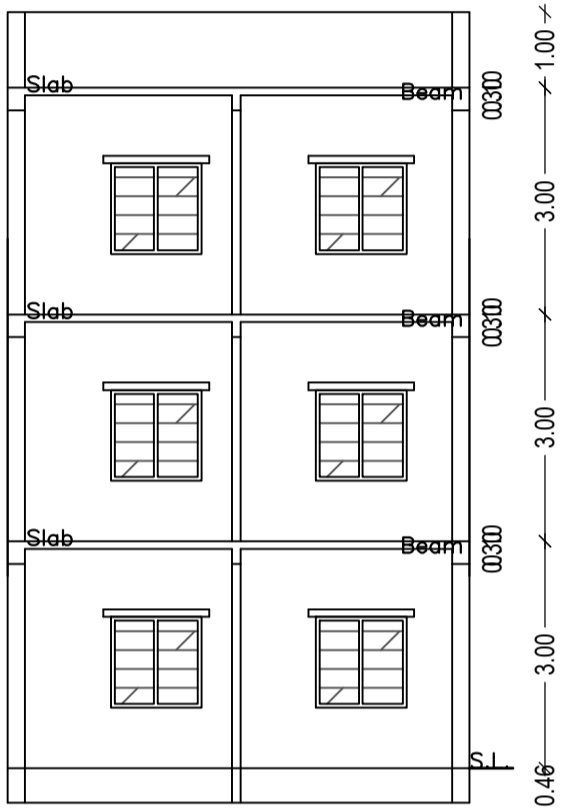
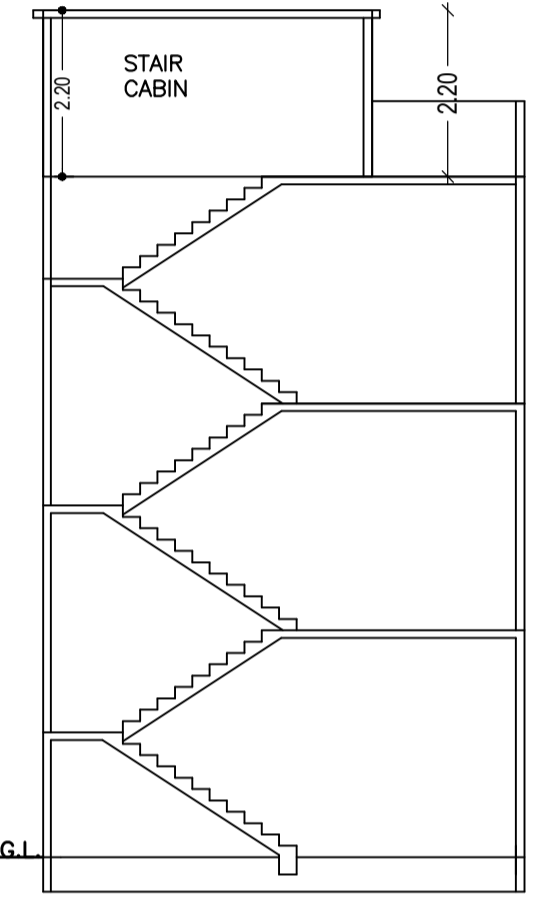
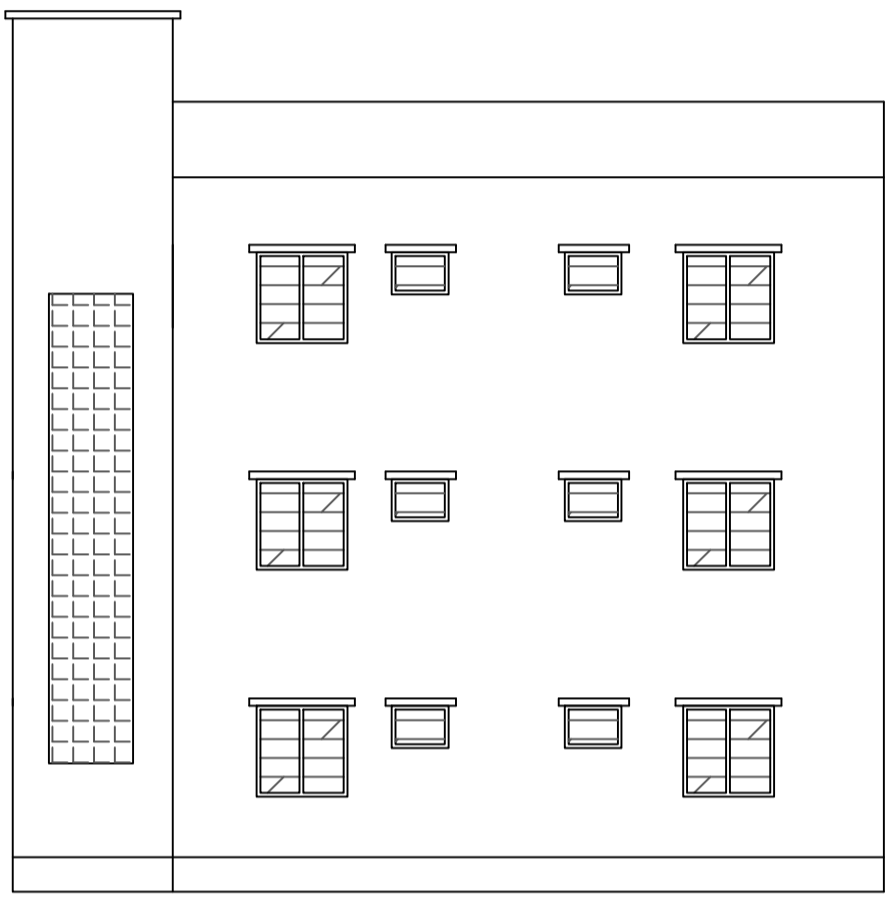
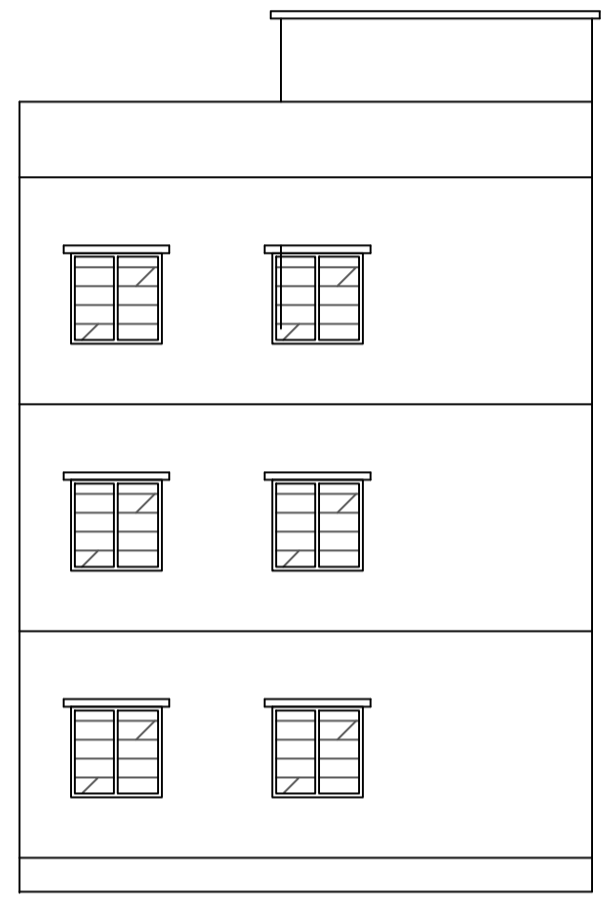
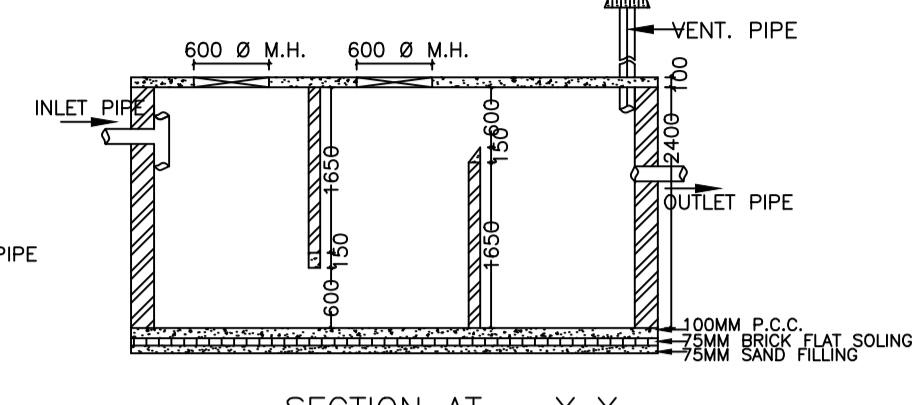
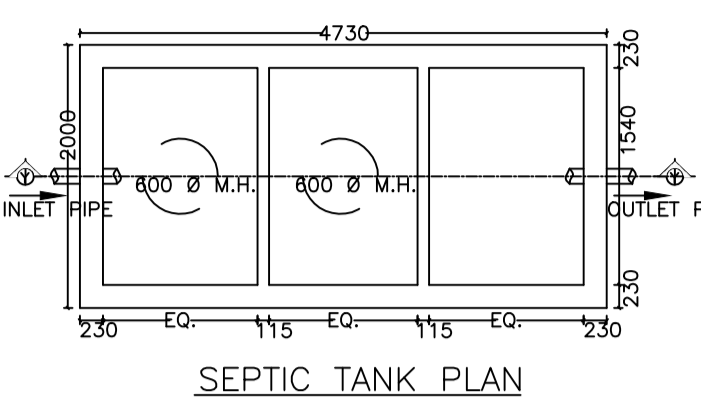
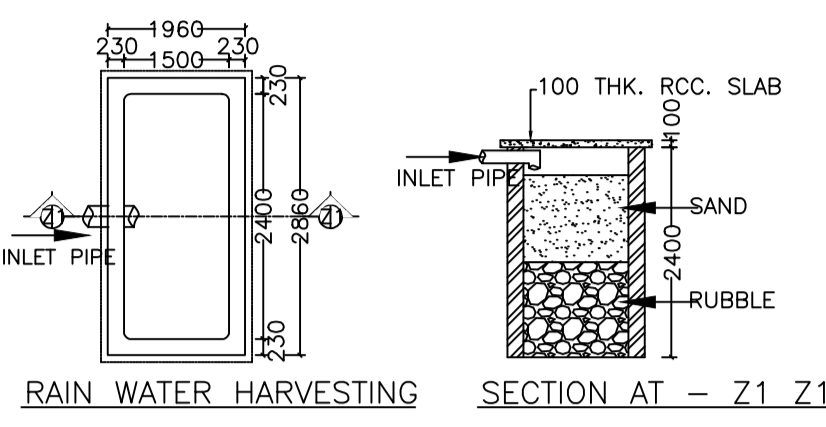
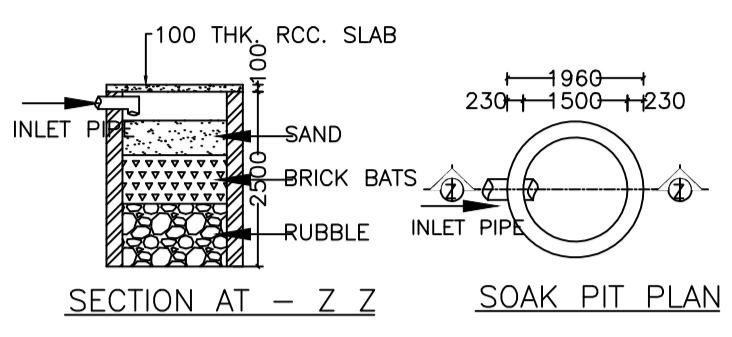
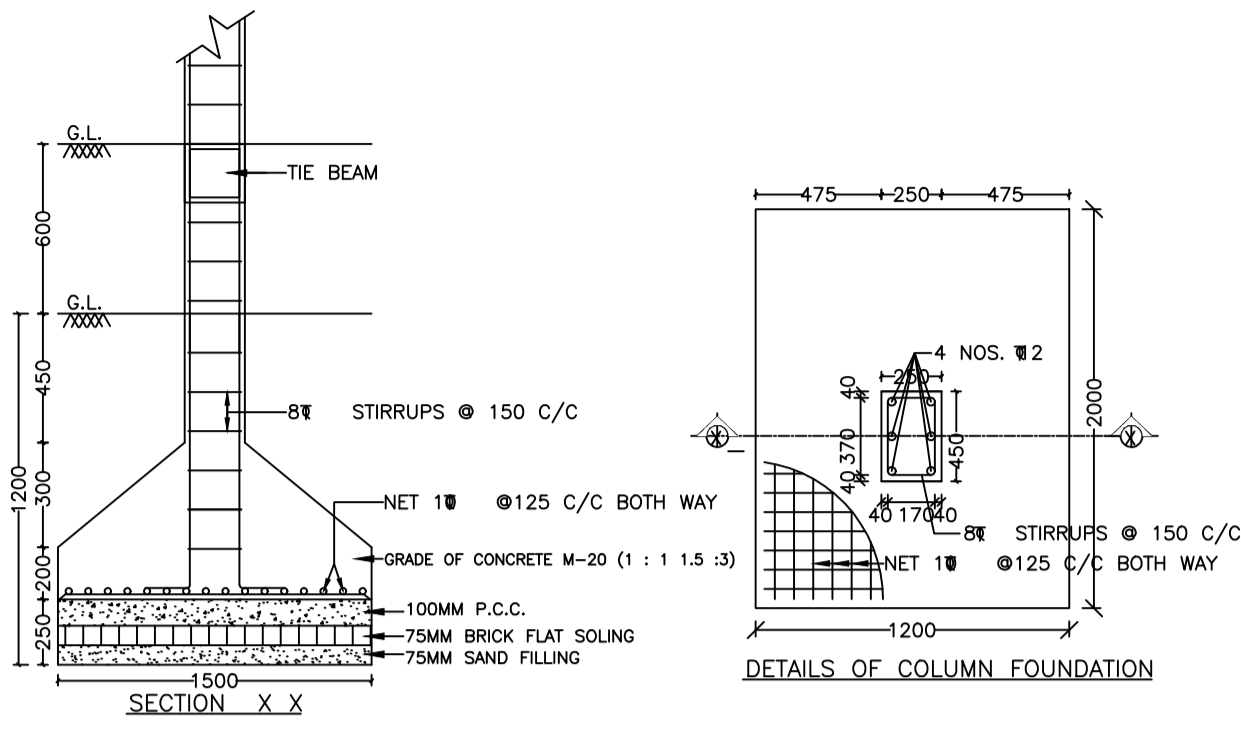
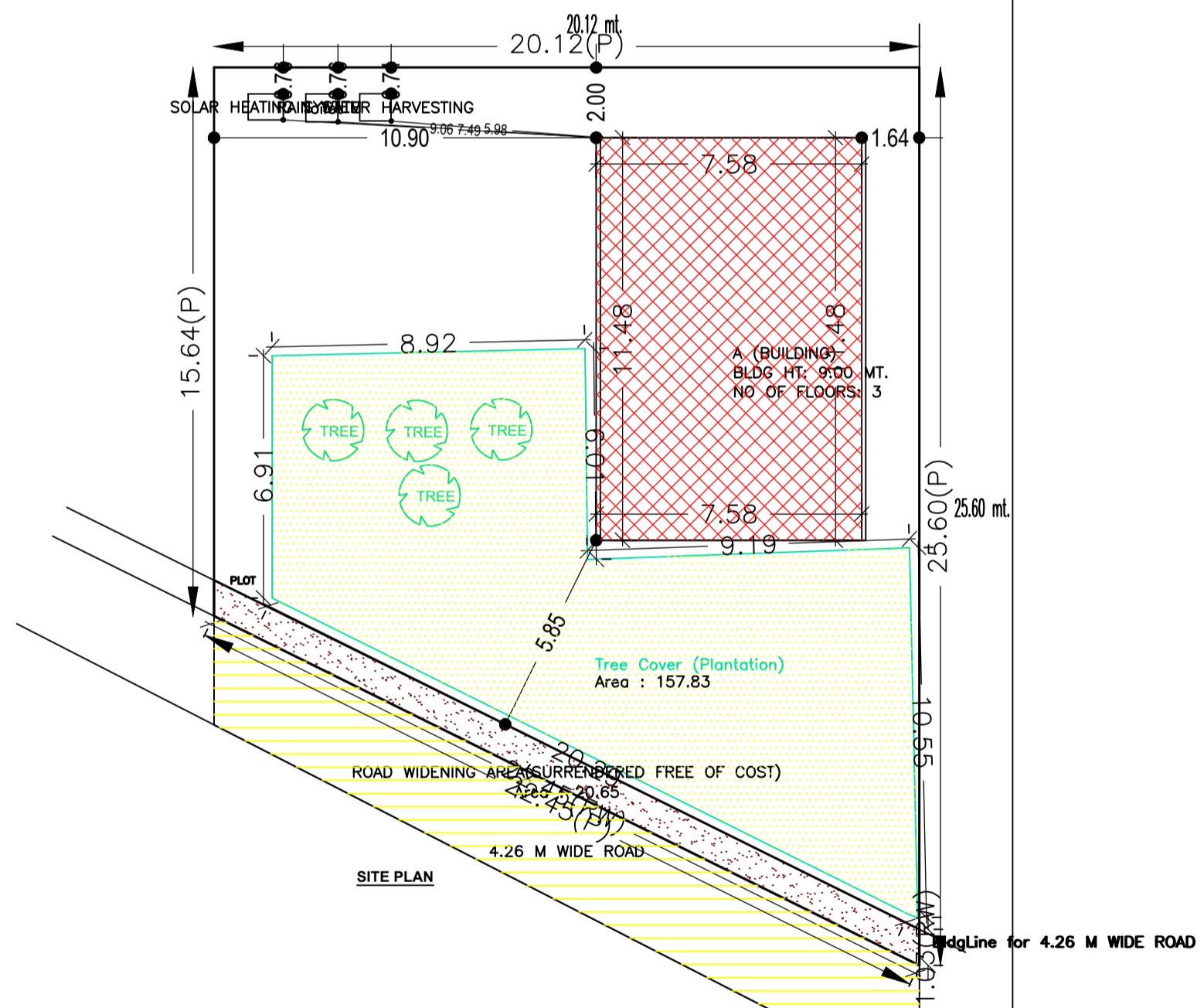
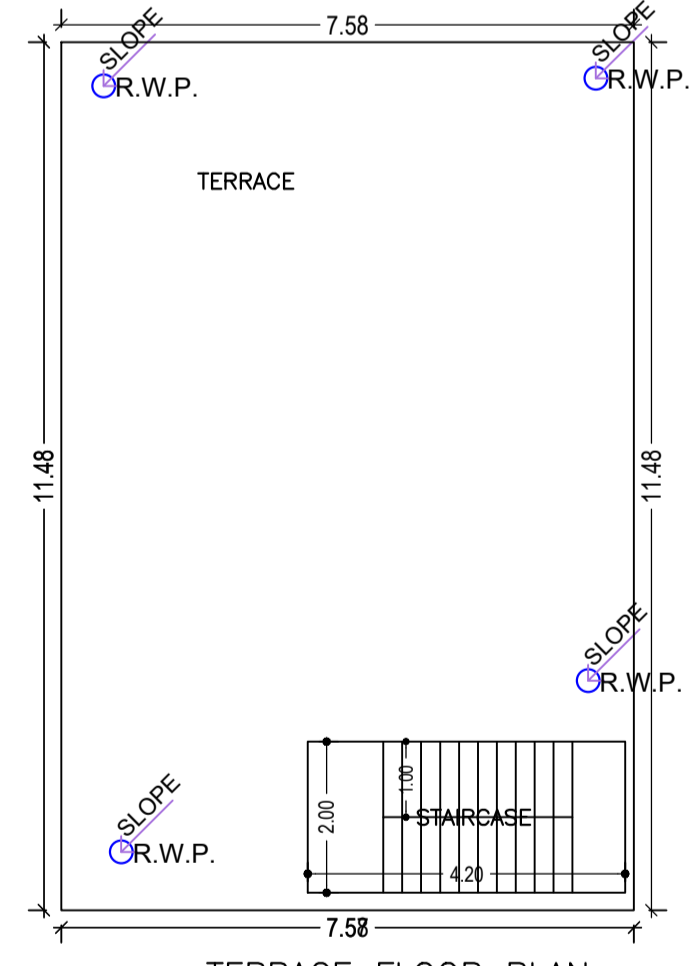
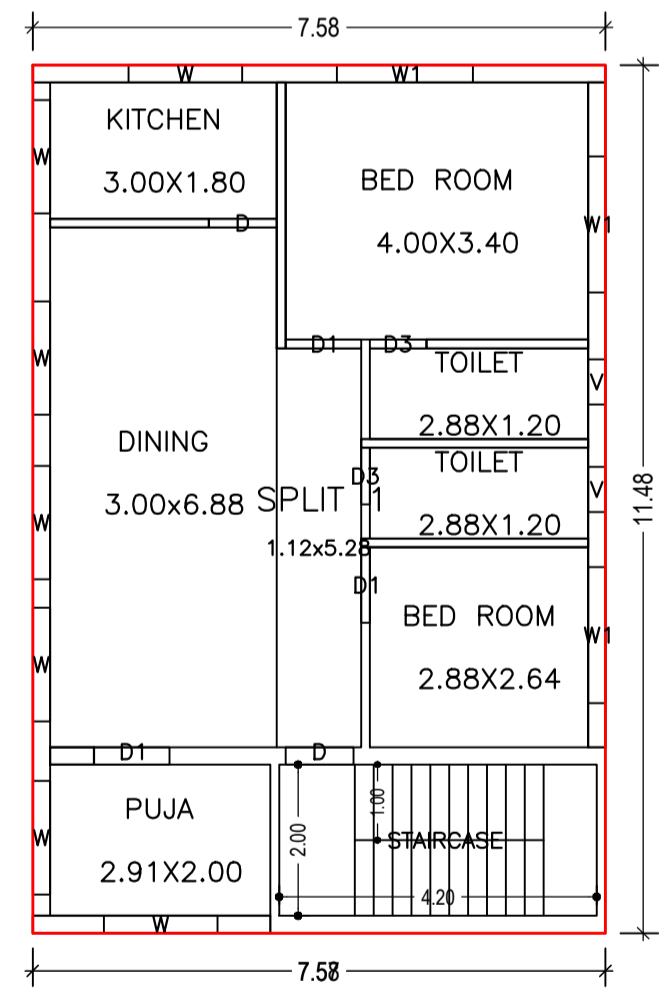
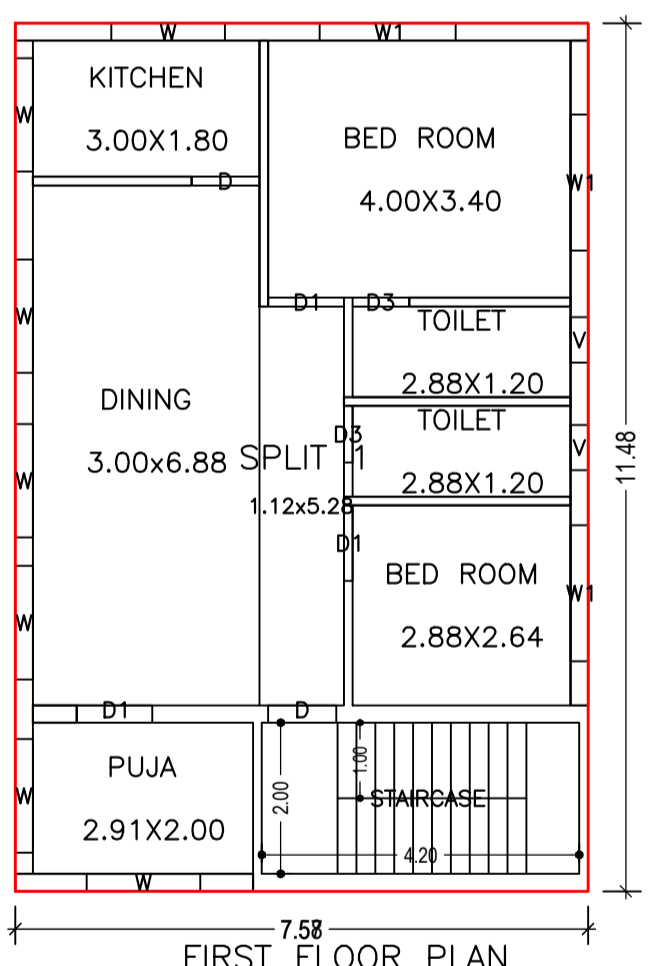
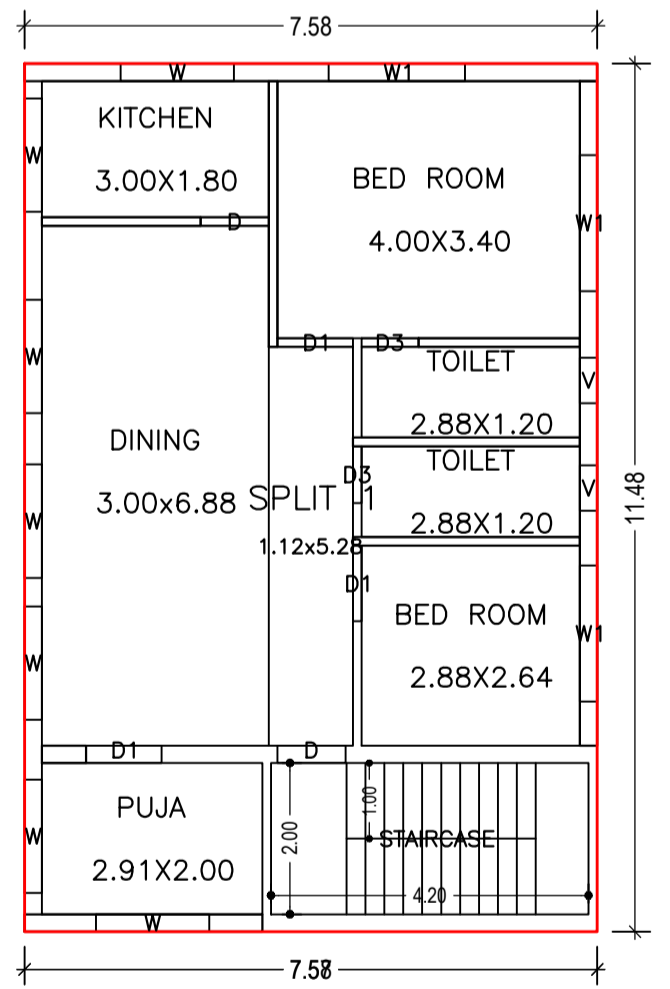

UnitBUA Table for Building :A (BUILDING)

FLOOR	Name	UnitBUA Type	UnitBUA Area	Carpet Area	No. of Rooms	No. of Tenement
GROUND FLOOR PLAN	SPLIT 1	FLAT	207.12	201.98	7	1
FIRST FLOOR PLAN	SPLIT 1	FLAT	0.00	0.00	7	0
SECOND FLOOR PLAN	SPLIT 1	FLAT	0.00	0.00	7	0
Total:	-	-	207.12	201.98	21	1

COLOR INDEX

PLOT BOUNDARY	ABUTTING ROAD	PROPOSED CONSTRUCTION	COMMON PLOT	ROAD WIDENING AREA	EXISTING (To be retained)	EXISTING (To be demolished)

Building USE/SUBUSE Details

Building Name	Building Use	Building SubUse	Building Structure
A (BUILDING)	Residential	Residential Bldg/Apartment	Non-Highrise

SCHEDULE OF DOOR:

BUILDING NAME	NAME	LENGTH	HEIGHT	NOS
A (BUILDING)	D3	0.75	2.10	06
A (BUILDING)	D	0.90	2.10	06
A (BUILDING)	D1	1.00	2.10	09

SCHEDULE OF WINDOW/VENTILATION:

BUILDING NAME	NAME	LENGTH	HEIGHT	NOS
A (BUILDING)	V	0.60	1.20	06
A (BUILDING)	W	1.50	1.20	21
A (BUILDING)	W1	1.80	1.20	09

LTP NAME AND SIGNATURE	STRUCTURAL ENG'S NAME AND SIGNATURE	BUILDER NAME AND SIGNATURE	DIGITAL SIGNATURE
MANOJ KUMAR CMC/SUP/0016/2018			