

Proposal Basic Information	
Proposal File No.	CMC/BP/0096/W06/2021
Owner Name	KAPUR SHARMA RAJARAM SHARMA
Khata No	25
Plot No	367,368
Village Name	Bhawanipur
Use	Residential
SubUse	Bungalow/ Dwelling / Non Apartment

AREA STATEMENT CHAS MUNICIPAL CORPORATION		VERSION NO.: 1.0.55
PROJECT DETAIL:		VERSION DATE: 16/10/2020
Region: JHARKHAND URBAN LOCAL BODIES	Plot Use: Residential	
District: BOKARO	Plot SubUse: Bungalow/ Dwelling / Non Apartment	
Authority: CHAS MUNICIPAL CORPORATION	PlotNearbyReligiousStructure: NA	
Inward No: CMC/BP/0096/W06/2021	PlotNo: 367,368	
Application Type: General Proposal	North: Plot No. - PLOT NO-369	
Project Type: Building Permission	South: Road Width - 6.0	
Nature of Development: New	East: Plot No. - PLOT NO-367	
Location of Development Area: Old Area	West: Road Width - 6.0	
AREA DETAILS:		SQ.MT.
AREA OF PLOT (Minimum)	(A)	365.37
NET AREA OF PLOT (Gross Plot Area - Deduction for Gross Plot area)	(A-Deductions)	365.37
Deduction for Balance Plot Area (from Gross Plot Area)		
Common Plot		44.49
Total		44.49
BALANCE AREA OF PLOT (Net Plot Area - Recreational/Amenity space)	(A-Deductions)	320.89
PLOT AREA FOR COVERAGE (Net Plot Area)	(A-Deductions)	365.37
Plot Area for FAR (Net Plot Area + Road Widening Area)	(A-Deductions)	365.37
COVERAGE CHECK		
Permissible Coverage area (60.00 %)		219.22
Proposed Coverage Area (59.97 %)		219.13
Total Prop. Coverage Area (59.97 %)		219.13
Balance coverage area (0.02 %)		0.09
FAR CHECK		
Perm. FAR Area (1.80)		657.67
Total Perm. FAR area		657.67
Residential FAR		438.27
Proposed FAR Area		438.27
Total Proposed FAR Area		438.27
Consumed FAR (Factor)		1.20
Balance FAR Area		219.40
BUILT UP AREA CHECK		
Total Proposed BuiltUp Area		438.26
ARCHITECT (Regd)	Trilochan Kumar Trivedi	
ENGINEER (Regd)		
SUPERVISOR (Regd)		
OWNER (Regd)	KAPUR SHARMA RAJARAM SHARMA	
DEVELOPMENT AUTHORITY		LOCAL BODY

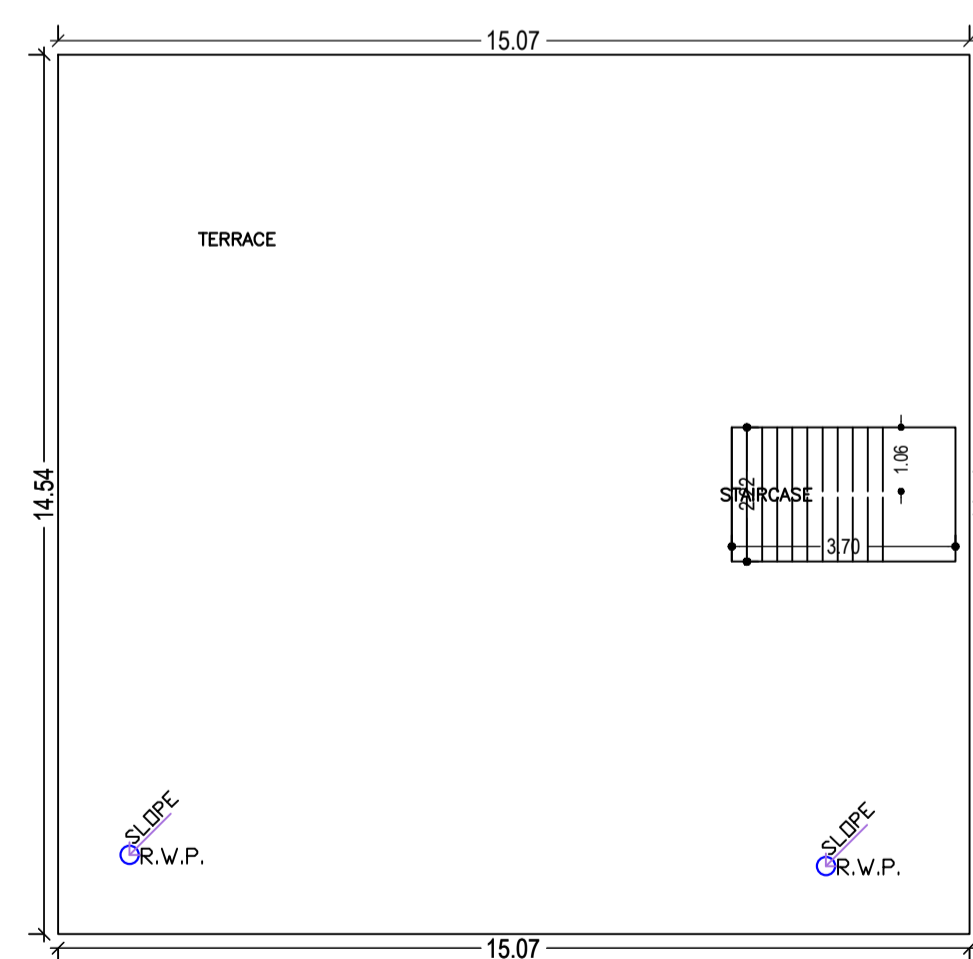
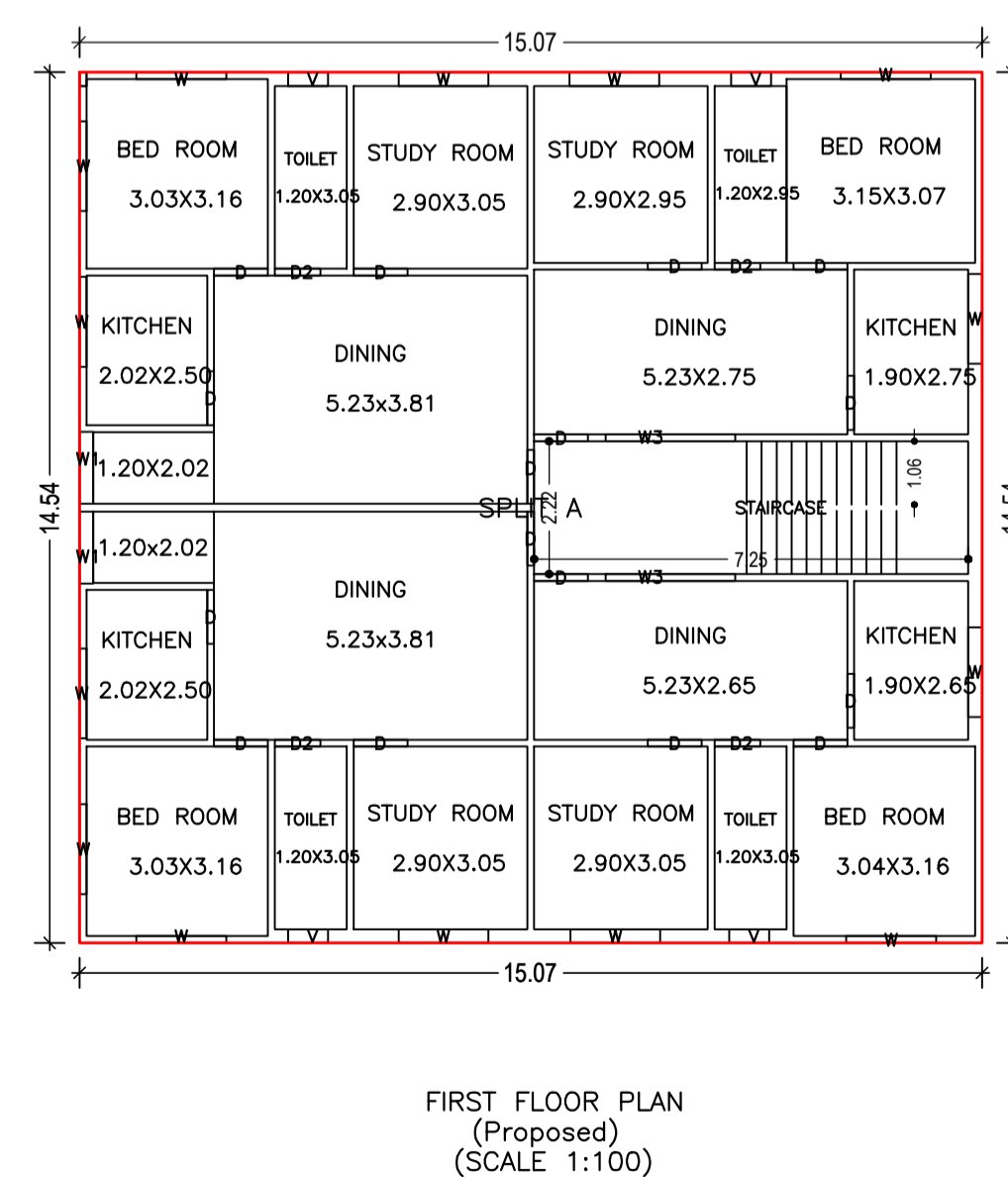
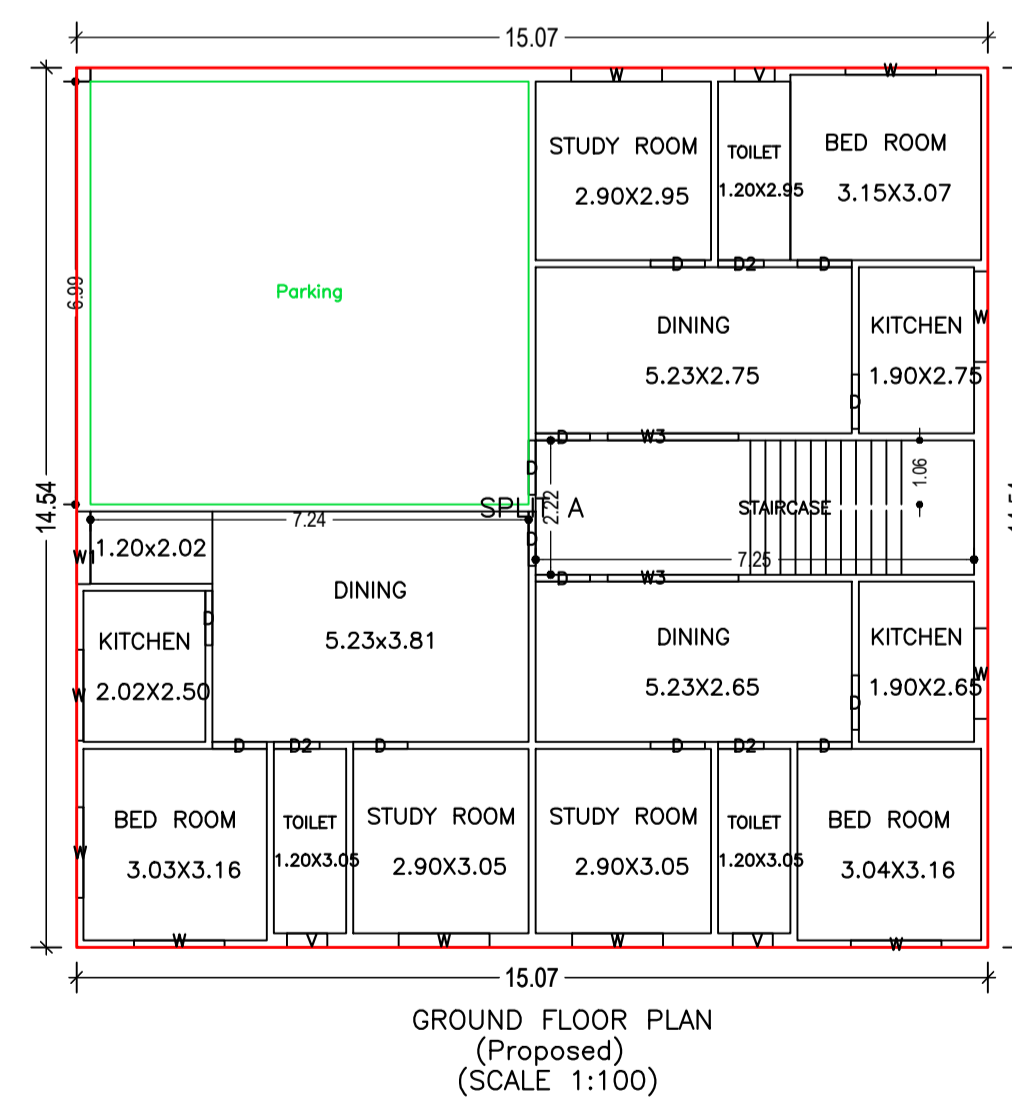
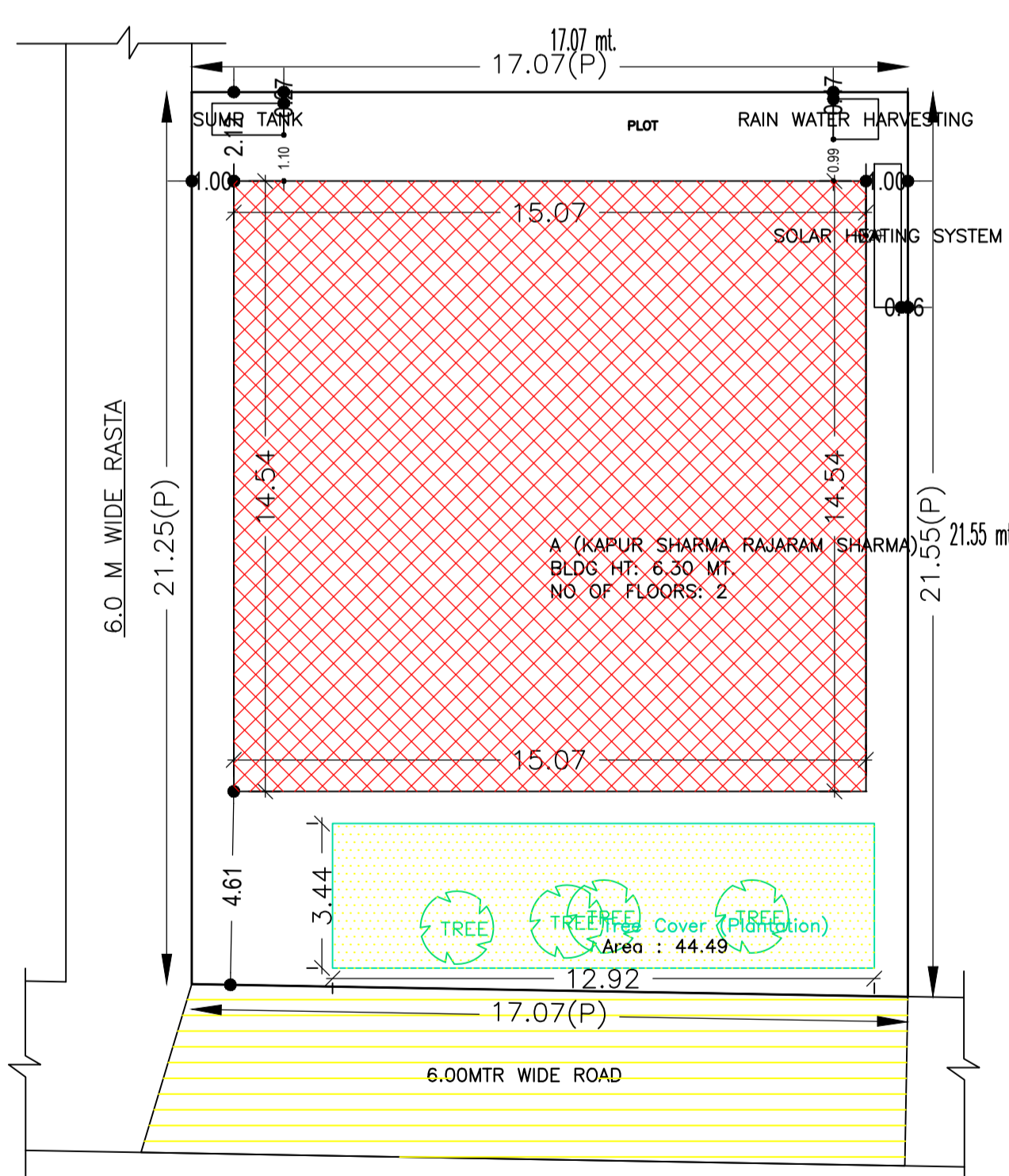
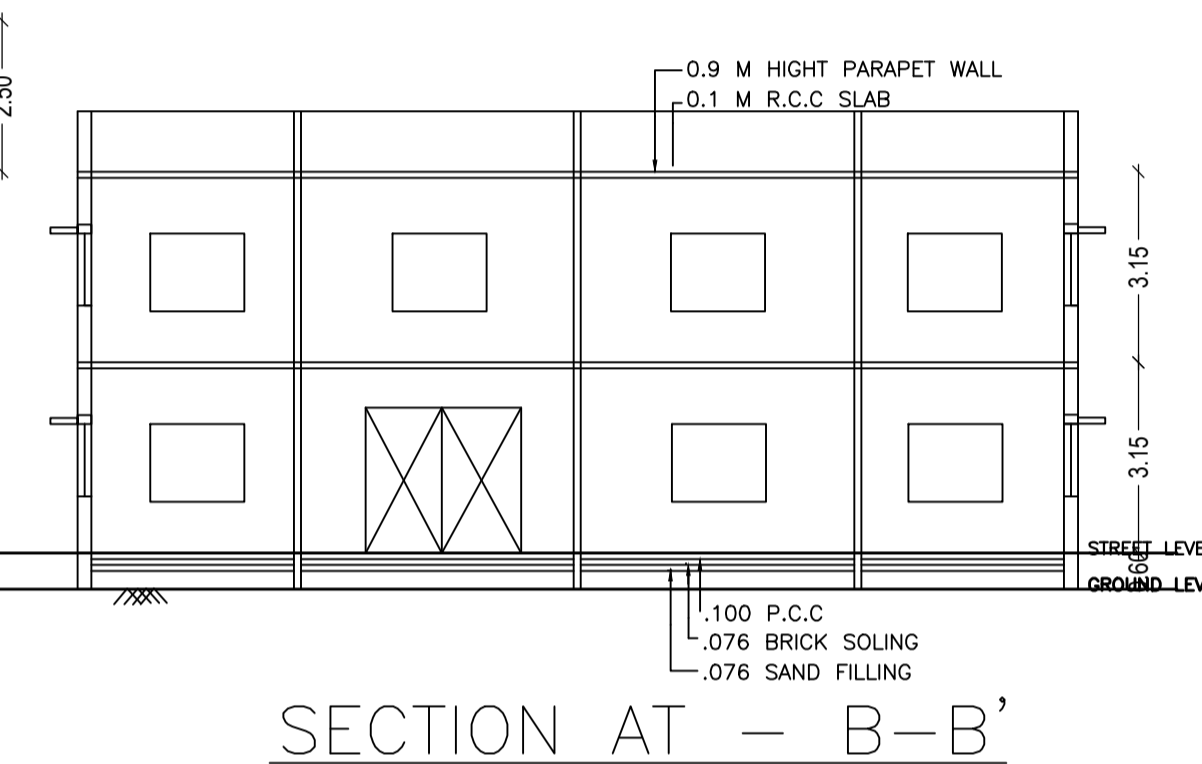
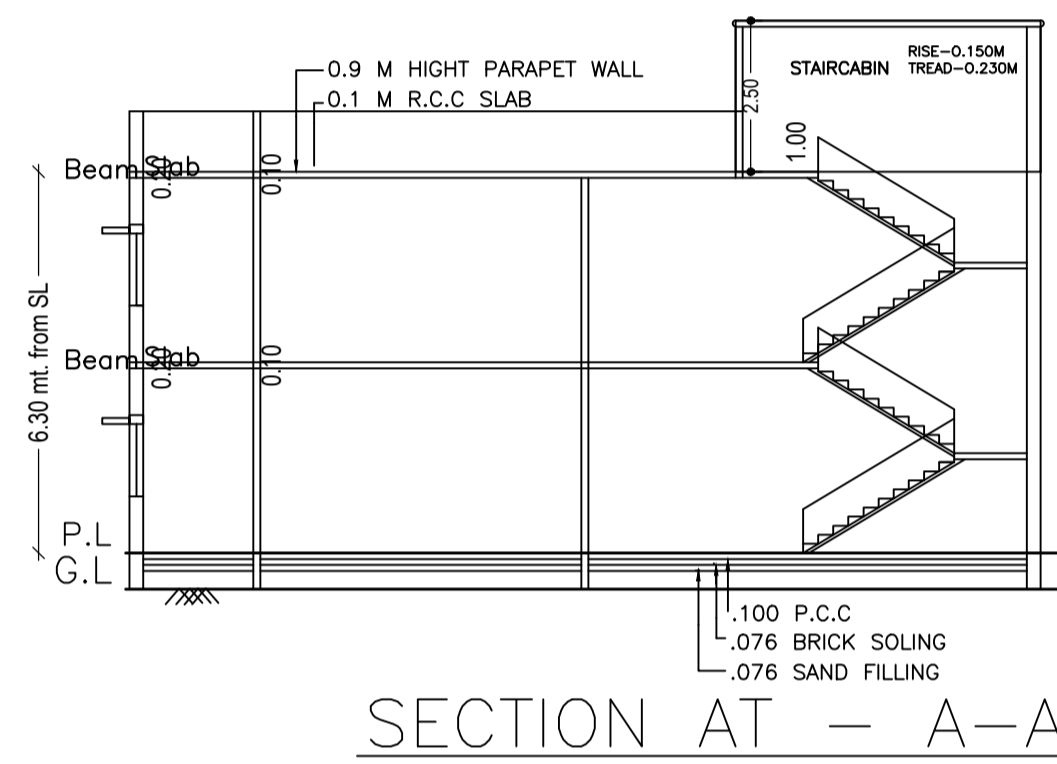
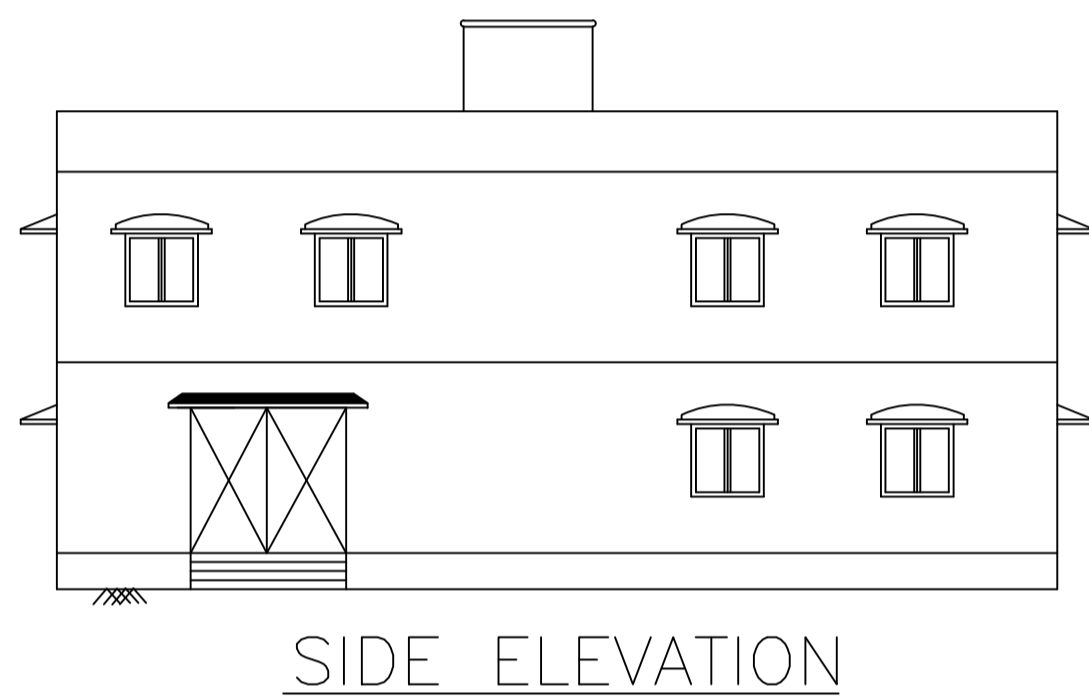
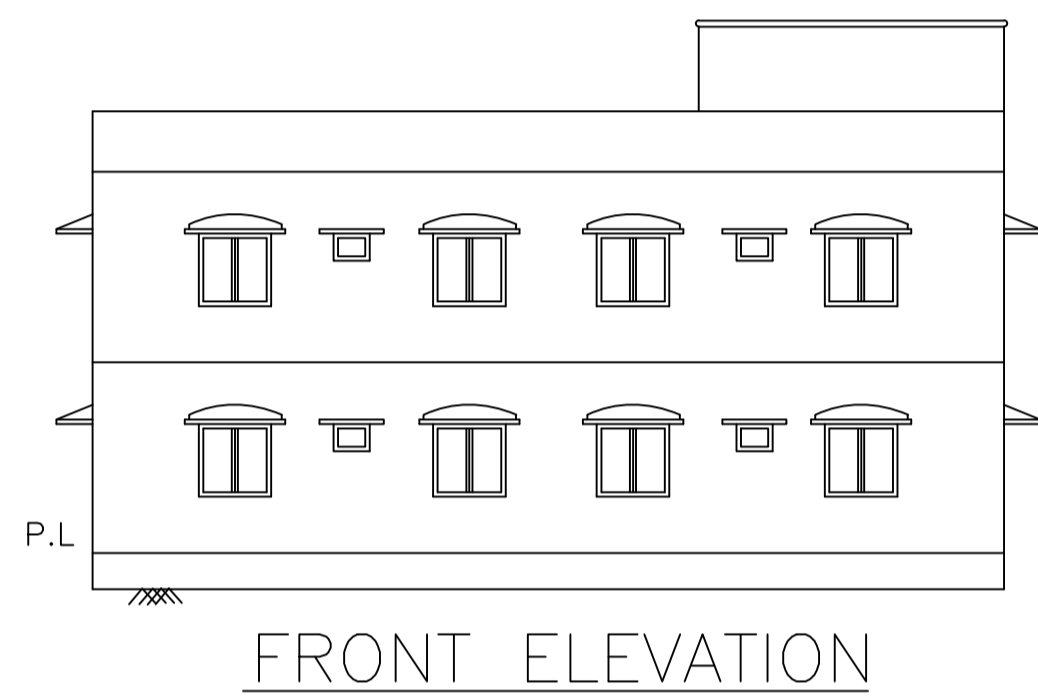

SCHEDULE OF DOOR:

BUILDING NAME	NAME	LENGTH	HEIGHT	NOS
A (KAPUR SHARMA RAJARAM SHARMA)	D2	0.76	2.10	07
A (KAPUR SHARMA RAJARAM SHARMA)	D	0.90	2.10	28

SCHEDULE OF WINDOW/VENTILATION:

BUILDING NAME	NAME	LENGTH	HEIGHT	NOS
A (KAPUR SHARMA RAJARAM SHARMA)	V	0.66	1.20	07
A (KAPUR SHARMA RAJARAM SHARMA)	W1	1.20	1.20	03
A (KAPUR SHARMA RAJARAM SHARMA)	W	1.50	1.20	24
A (KAPUR SHARMA RAJARAM SHARMA)	W3	2.16	1.20	04

Building :A (KAPUR SHARMA RAJARAM SHARMA)

Floor Name	Total Built Up Area (Sq.mt.)	Proposed FAR Area (Sq.mt.) Resi.	Total FAR Area (Sq.mt.)	Total Consumed Additional FAR Area (Sq.mt.)	Trmt (No.)
Ground Floor	219.13	219.13	219.13	219.13	01
First Floor	219.13	219.13	219.13	219.13	00
Terrace Floor	0.00	0.00	0.00	0.00	00
Total:	438.26	438.26	438.26	438.26	01
Total Number of Same Buildings :	1				
Total :	438.26	438.26	438.26	438.26	01

Building USE/SUBUSE Details

Building Name	Building Use	Building SubUse	Building Structure
A (KAPUR SHARMA RAJARAM SHARMA)	Residential	Bungalow/ Dwelling / Non Apartment	Non-Highrise

FAR & Tenement Details (Table 4c-1)

Building	No. of Same Bldg	Total Built Up Area (Sq.mt.)	Proposed FAR Area (Sq.mt.) Resi.	Total FAR Area (Sq.mt.)	Total Consumed Additional FAR Area (Sq.mt.)	Trmt (No.)
A (KAPUR SHARMA RAJARAM SHARMA)	1	438.26	438.26	438.26	438.26	01
Grand Total:	1	438.26	438.26	438.26	438.26	01

Buildingwise Floor FAR Details

Floor Name	Building Name		Total	
	Proposed Built Up Area (Sq.mt.)	Proposed FAR Area (Sq.mt.)	Total Proposed Built Up Area (Sq.mt.)	Total FAR Area (Sq.mt.)
Ground Floor	219.13	219.13	219.13	219.13
First Floor	219.13	219.13	219.13	219.13
Terrace Floor	0.00	0.00	0.00	0.00
Total :	438.26	438.26	438.26	438.26

UnitBUA Table for Building :A (KAPUR SHARMA RAJARAM SHARMA)

FLOOR	Name	UnitBUA Type	UnitBUA Area	Carpel Area	No. of Rooms	No. of Tenement
GROUND FLOOR PLAN	SPLIT A	FLAT	438.27	438.19	15	1
FIRST FLOOR PLAN	SPLIT A	FLAT	0.00	0.00	20	0
Total:	-	-	438.27	438.19	35	1

COLOR INDEX

PLOT BOUNDARY	[Red Line]
ABUTTING ROAD	[Green Line]
PROPOSED CONSTRUCTION	[Yellow Line]
COMMON PLOT	[Blue Line]
ROAD WIDENING AREA	[Orange Line]
EXISTING (To be retained)	[Grey Line]
EXISTING (To be demolished)	[Black Line]

LTP NAME AND SIGNATURE	STRUCTURAL ENG'S NAME AND SIGNATURE	BUILDER NAME AND SIGNATURE	DIGITAL SIGNATURE
Trilochan Kumar Trivedi CMC/SUP/0003/2017			