

Project Title - SMT RITA DEVI

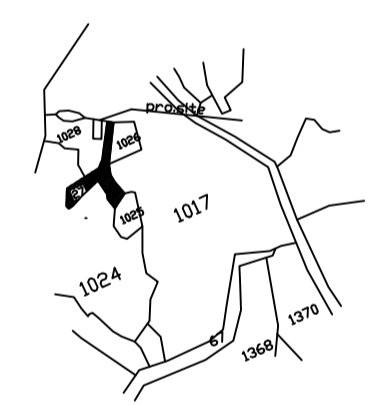
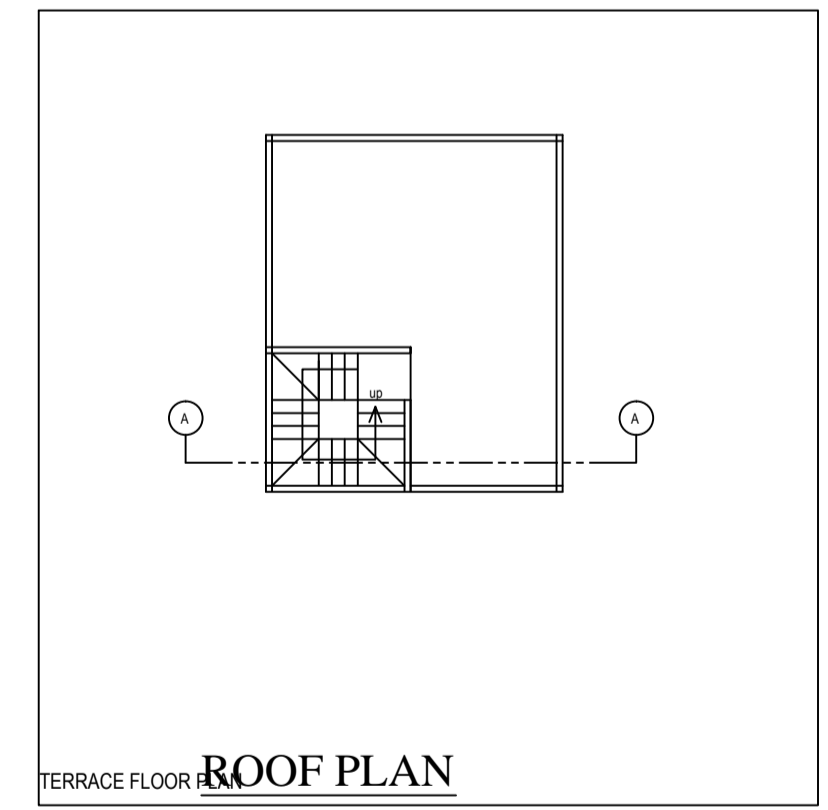
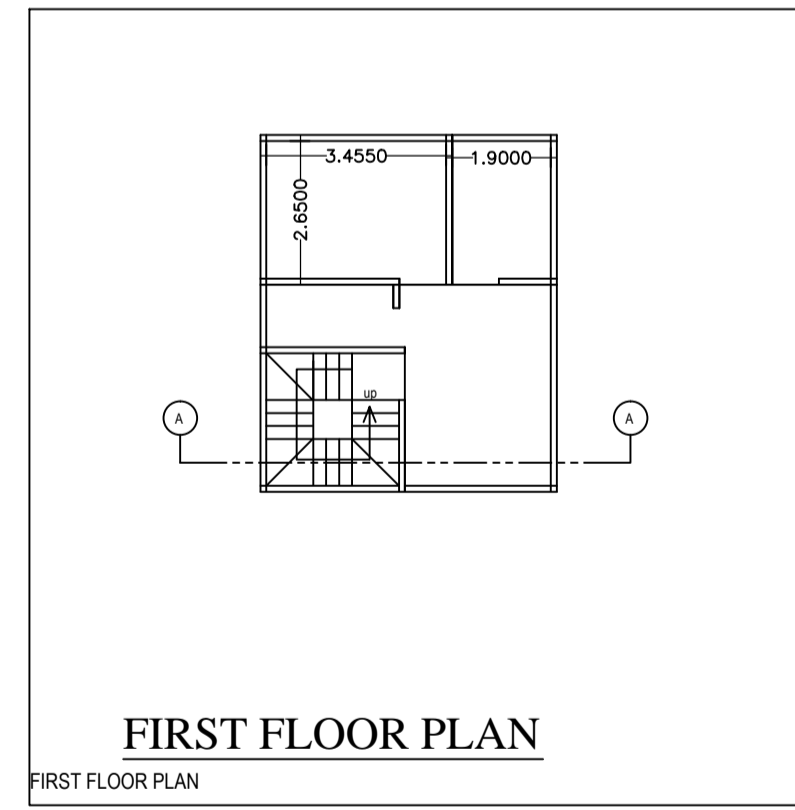
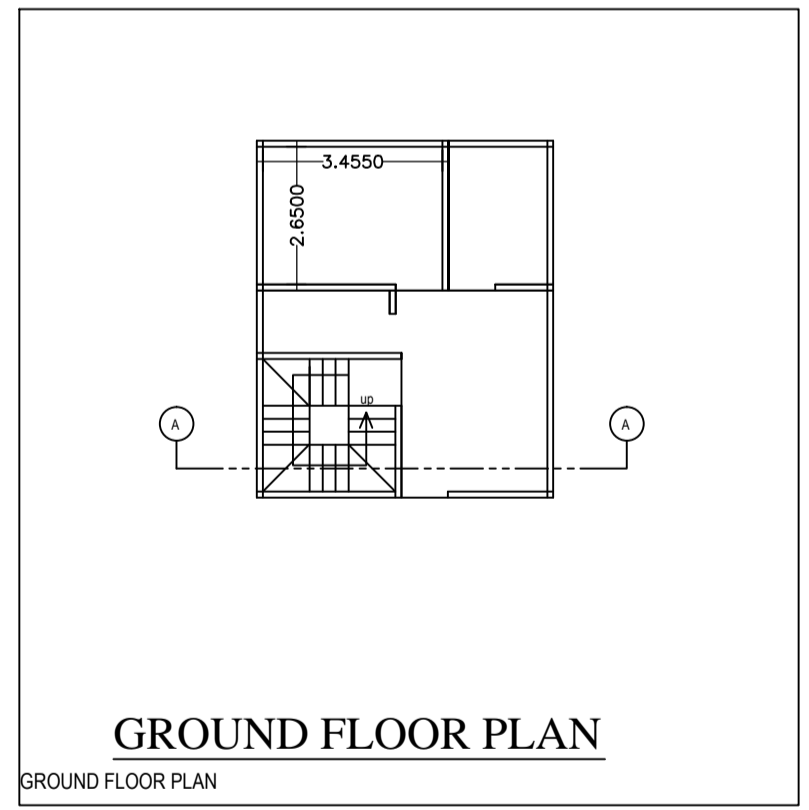
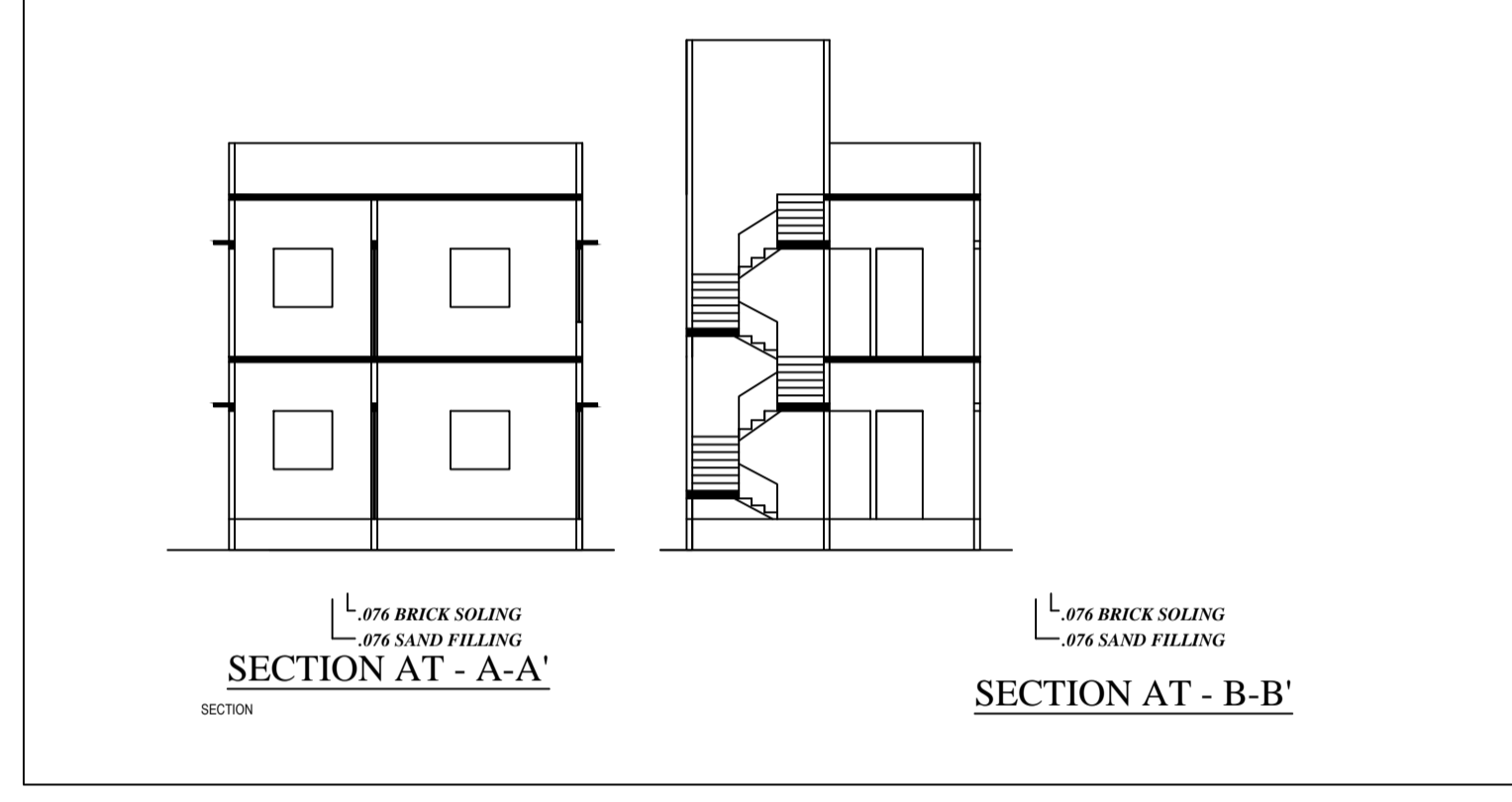
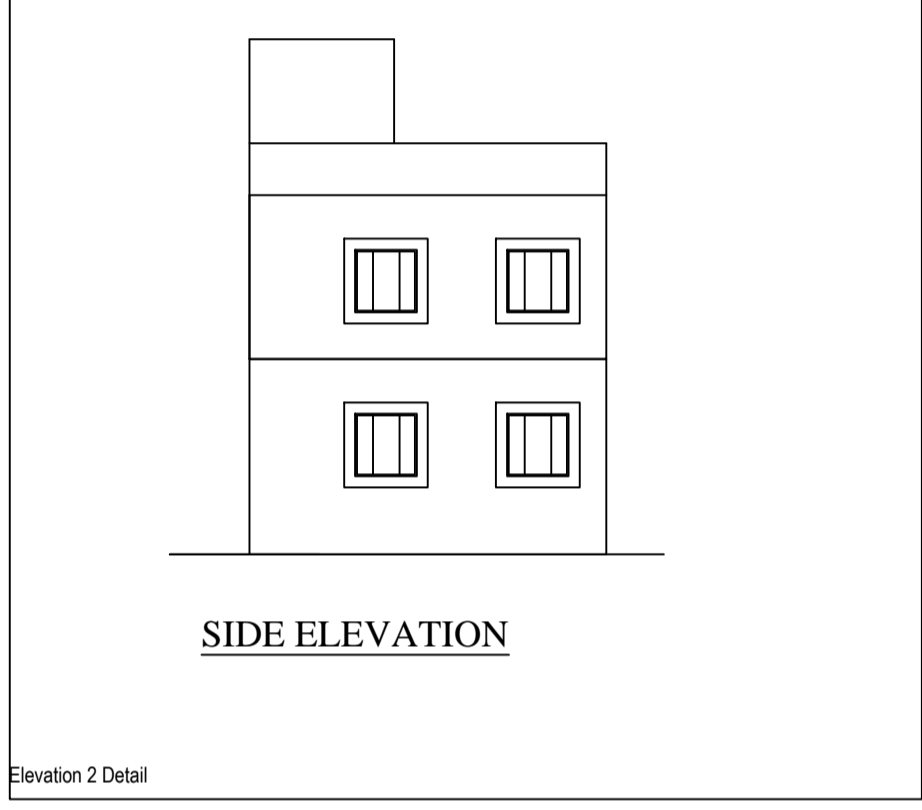
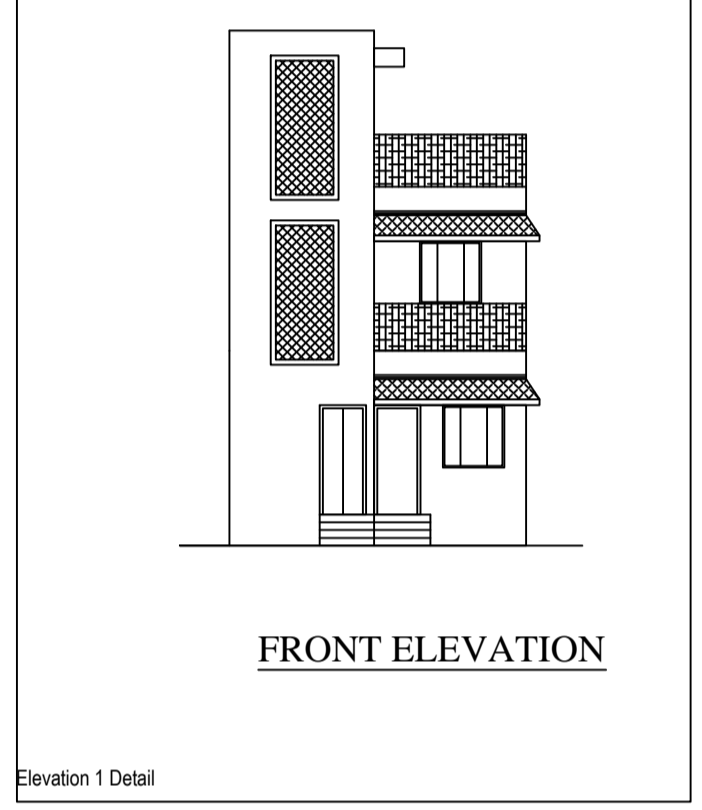
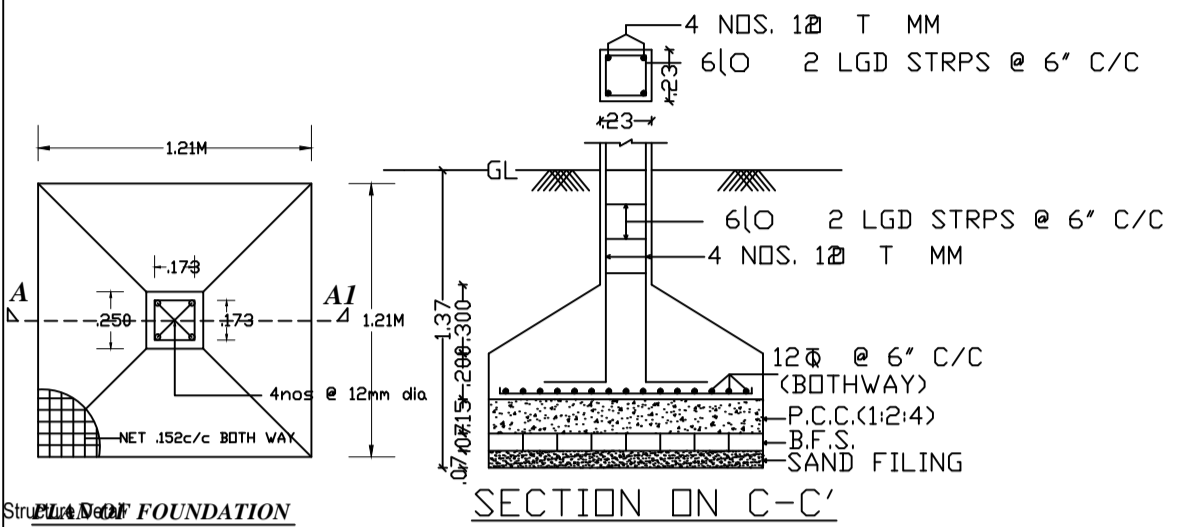
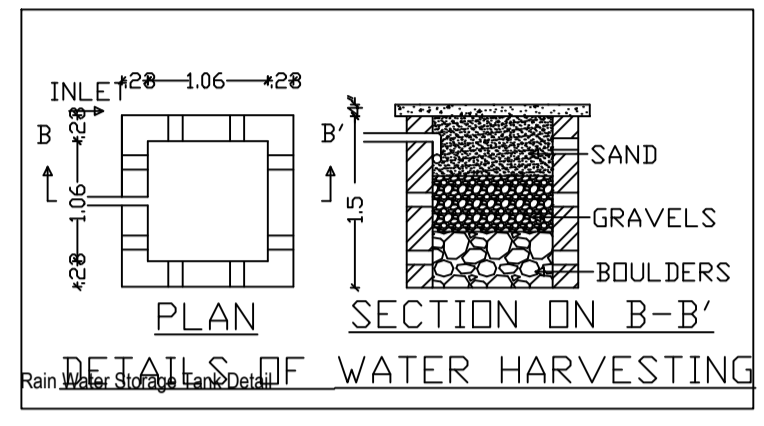
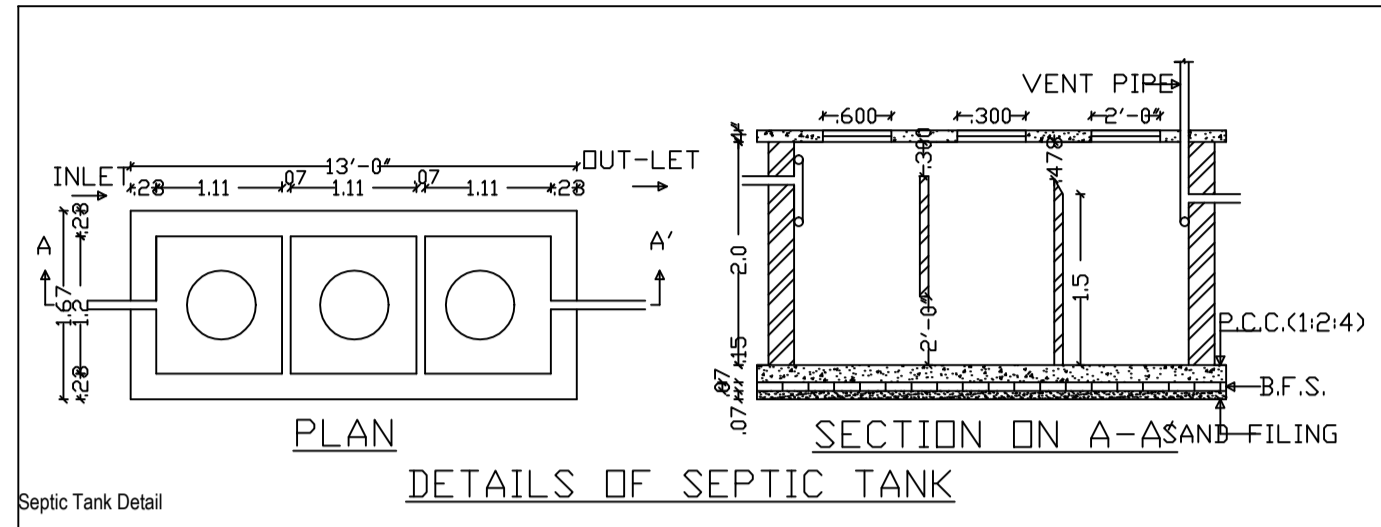

BRIEF SPECIFICATION

FOUNDATION-----CEMENT CONCRETE
 BRICK WORK IN FOUNDATION & SUPERSTRUCTURE
 FIRST CLASS BRICK WORK IN CEMENT MOR.(1:6)
 D.P.C.---1" D.P.C. IN CEMENT CDN. (1:2:4)
 FLOOR-----1" I.P.S. OVER 3" P.C.C.
 ROOF-----4"THK. R.C.C. ROOF (1:1.5:3)
 LINTEL-----6"THK. R.C.C. LINTEL (1:1.5:3)
 STAIRS-----RISE---7", TREAD--- 10"
 DOORS---D-3'3"x7'0" D1-3'0"x7'0",D2-2'6"x7'0"
 WINDOWS-----W-4'0"x4'0",W1-3'0"x4'0"
 VENTS-----V-2'0"x2'0"

0.9000

| STATEMENT OF AREA | |
|-----------------------------|------------------------|
| TOTAL PLOT AREA-222.95 SQM | BOUNDARIES |
| GROUND FLOOR AR-137.49 SQM | N. K/488 MARKED PLOT |
| FIRST FLOOR AREA-137.49 SQM | S. K/488 MARKED PLOT |
| TOTAL COV. AREA-274.99SQM | E- 4.5 M WIDE ROAD |
| % OF COV ----- 61.66% | W- SURVEY PLOT NO-3632 |
| FAR ----- 1.23 | |

DRG NO----- DRAWN BY-----

SIGNATURE OF OWNERS SIGNATURE OF ENGINEERS

