

FRONT ELEVATION

SIDE ELEVATION

SECTION AT-A-A

SECTION AT-B-B

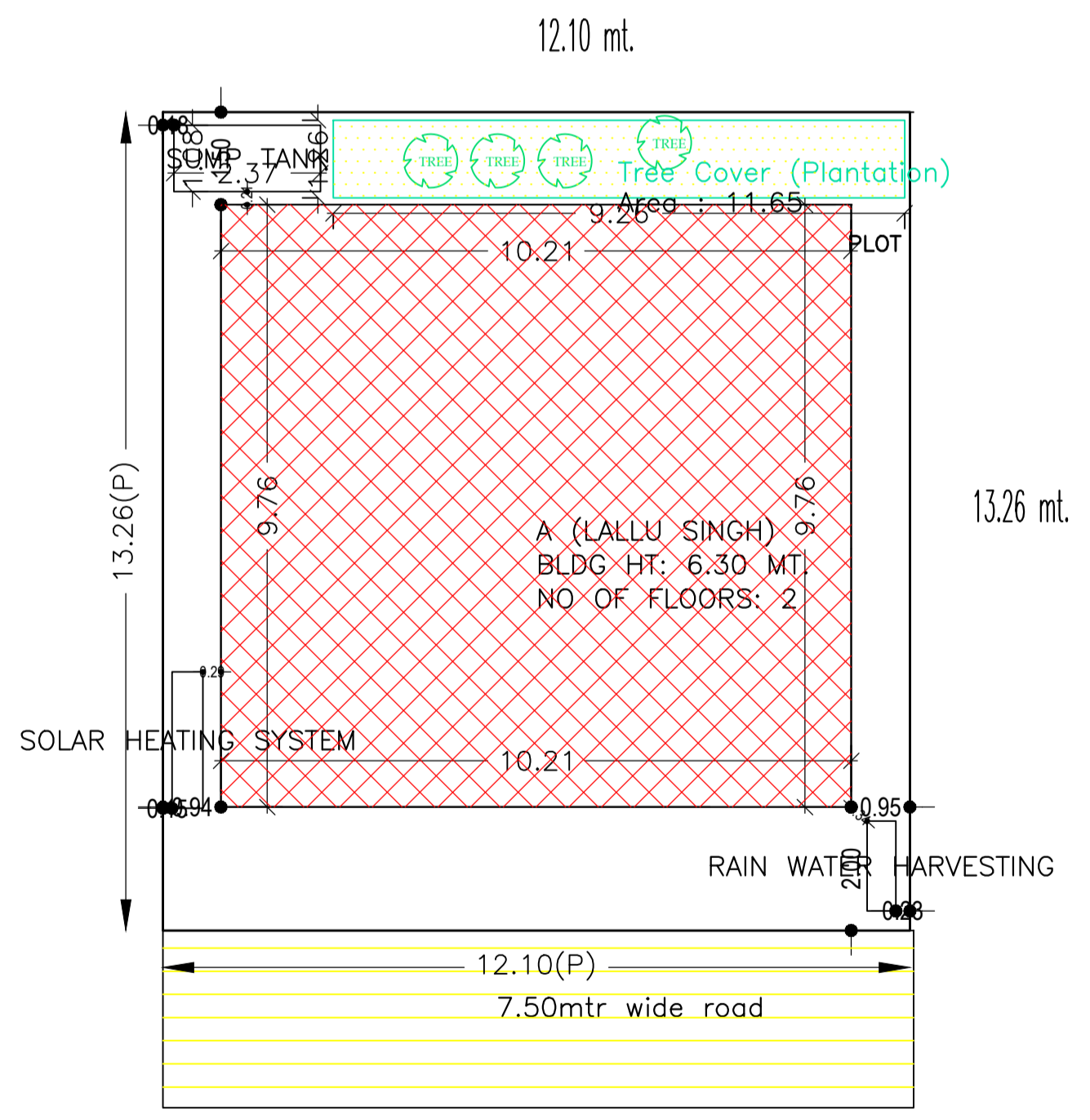
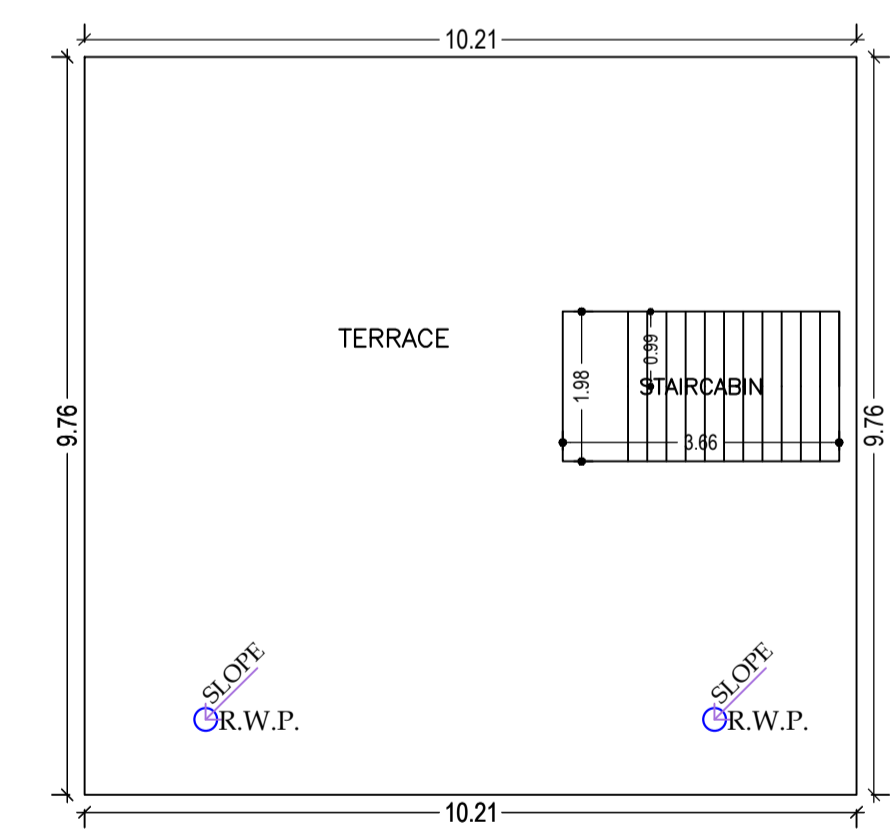
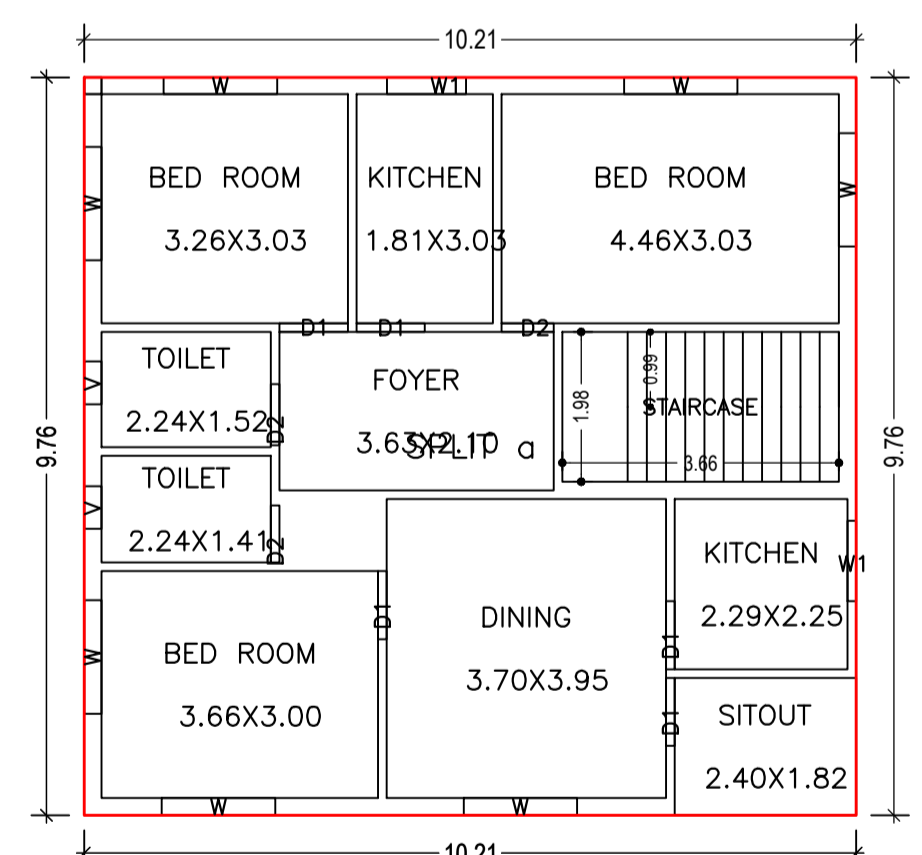
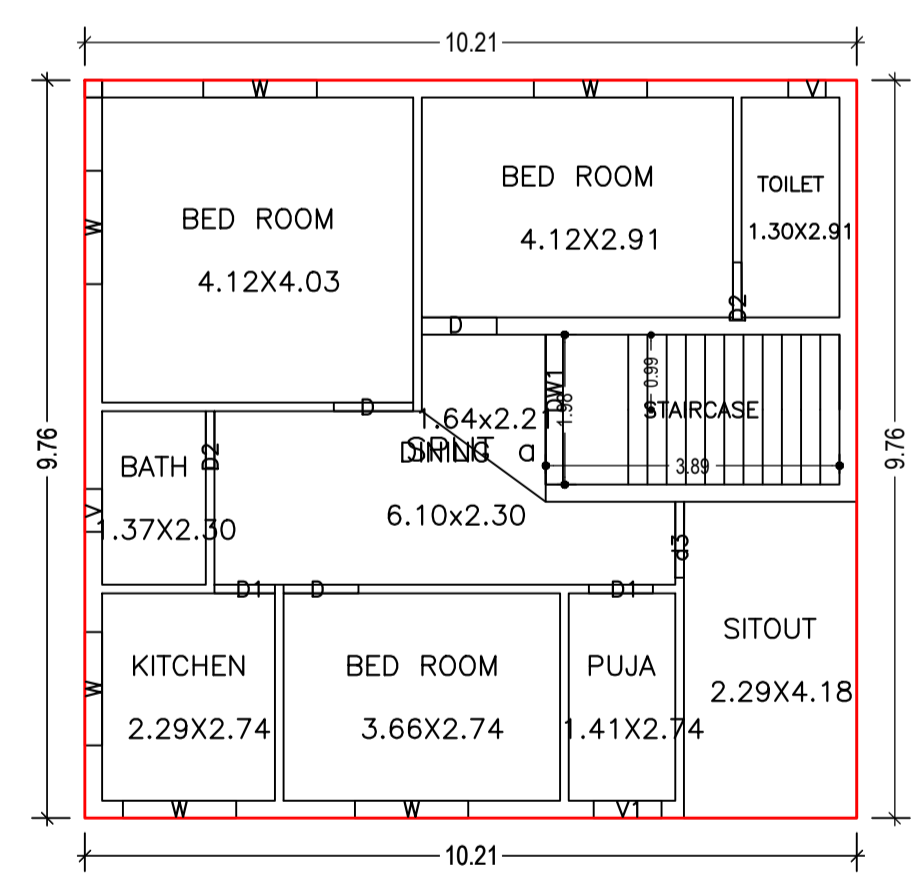

GROUND FLOOR PLAN (Proposed) (SCALE 1:100)

FIRST FLOOR PLAN (Proposed) (SCALE 1:100)

TERRACE FLOOR PLAN (SCALE 1:100)

SITE PLAN

Building :A (LALLU SINGH)

Floor Name	Total Built Up Area (Sq.mt.)	Proposed FAR Area (Sq.mt.)	Total FAR Area (Sq.mt.)	Total Consumed Additional FAR Area (Sq.mt.)	Tnmt (No.)
Ground Floor	99.66	99.66	99.66	99.66	01
First Floor	99.66	99.66	99.66	99.66	00
Terrace Floor	0.00	0.00	0.00	0.00	00
Total :	199.32	199.32	199.32	199.32	01
Total Number of Same Buildings :	1				
Total :	199.32	199.32	199.32	199.32	01

Buildingwise Floor FAR Details

Floor Name	Building Name A (LALLU SINGH)		Total	
	Proposed Built Up Area (Sq.mt.)	Proposed FAR Area (Sq.mt.)	Total Proposed Built Up Area (Sq.mt.)	Total FAR Area (Sq.mt.)
Ground Floor	99.66	99.66	99.66	99.66
First Floor	99.66	99.66	99.66	99.66
Terrace Floor	0.00	0.00	0.00	0.00
Total :	199.32	199.32	199.32	199.32

**COLOR INDEX**

- PLOT BOUNDARY: Black
- ABUTTING ROAD: Red
- PROPOSED CONSTRUCTION: Green
- COMMON PLOT: Yellow
- ROAD WIDENING AREA: Blue
- EXISTING (To be retained): Orange
- EXISTING (To be demolished): Grey

UnitBUA Table for Building :A (LALLU SINGH)

FLOOR	Name	UnitBUA Type	UnitBUA Area	Carpet Area	No. of Rooms	No. of Tenement
GROUND FLOOR PLAN	SPLIT a	FLAT	199.32	199.22	9	1
FIRST FLOOR PLAN	SPLIT a	FLAT	0.00	0.00	10	0
Total:	-	-	199.32	199.22	19	1

AREA STATEMENT CHAS MUNICIPAL CORPORATION		VERSION NO.: 1.0.55
		VERSION DATE: 16/10/2020
<b>PROJECT DETAIL:</b>		
Region: JHARKHAND URBAN	Plot Use: Residential	
Local Bodies	Plot SubUse: Bungalow/ Dwelling / Non Apartment	
District: BOKARO	Plot Neaby/ReligiousStructure: NA	
Authority: CHAS MUNICIPAL CORPORATION		
Inward_No: CMC/BP/0092/W30/2021	Plot/SubPlot No: 16 OLD.11 NEW	
Application Type: General Proposal	North: Plot No. - PLOT NO.- 15 N.H.B	
Project Type: Building Permission	South: CTS No. - CO-OPERATIVE LAND	
Nature of Development: New	East: Road Width - 7.50 MTR WIDE ROAD	
Location of Development Area: Old Area	West: Plot No. - PLOT NO.- 14 NH B	
<b>AREA DETAILS:</b>		
AREA OF PLOT (Minimum)	(A)	SQ.MT. 160.46
NET AREA OF PLOT(Gross Plot Area - Deduction from Gross Plot area)	(A-Deductions)	160.46
Deduction for Balance Plot Area(from Gross Plot Area)		
Common Plot		11.65
Total		11.65
BALANCE AREA OF PLOT(Net Plot Area - Recreational/Amenity space)	(A-Deductions)	148.82
PLOT AREA FOR COVERAGE(Net Plot Area)	(A-Deductions)	160.46
Plot Area for FAR (Net Plot Area + RoadWidening Area)	(A-Deductions)	160.46
<b>COVERAGE CHECK</b>		
Permissible Coverage area ( 70.00 % )		112.32
Proposed Coverage Area ( 62.11 % )		99.66
Total Prop. Coverage Area ( 62.11 % )		99.66
Balance coverage area ( 7.89 % )		12.66
<b>FAR CHECK</b>		
Perm. FAR Area ( 2.50 )		401.15
Total Perm. FAR area		401.15
Residential FAR		199.32
Proposed FAR Area		199.32
Total Proposed FAR Area		199.32
Consumed FAR (Factor)		1.24
Balance FAR Area		201.83
<b>BUILT UP AREA CHECK</b>		
Total Proposed BuiltUp Area		199.32
ARCHITECT (Regd)	AMRIT KUMAR MAHATO	
ENGINEER (Regd)		
SUPERVISOR (Regd)		
OWNER (Regd)	LALLU SINGH	
DEVELOPMENT AUTHORITY	LOCAL BODY	

SCHEDULE OF DOOR:

BUILDING NAME	NAME	LENGTH	HEIGHT	NOS
A (LALLU SINGH)	D2	0.69	2.10	01
A (LALLU SINGH)	D2	0.75	2.10	03
A (LALLU SINGH)	D1	0.80	2.10	01
A (LALLU SINGH)	D2	0.81	2.10	01
A (LALLU SINGH)	D1	0.85	2.10	01
A (LALLU SINGH)	D1	0.90	2.10	03
A (LALLU SINGH)	D1	0.91	2.10	02
A (LALLU SINGH)	D	0.99	2.10	02
A (LALLU SINGH)	d3	1.00	2.10	01
A (LALLU SINGH)	D	1.05	2.10	01

SCHEDULE OF WINDOW/VENTILATION:

BUILDING NAME	NAME	LENGTH	HEIGHT	NOS
A (LALLU SINGH)	V	0.49	1.20	01
A (LALLU SINGH)	V	0.57	1.20	03
A (LALLU SINGH)	V1	0.90	1.20	01
A (LALLU SINGH)	W1	1.05	1.20	01
A (LALLU SINGH)	W1	1.07	1.20	01
A (LALLU SINGH)	W	1.50	1.20	13
A (LALLU SINGH)	DW1	1.98	1.20	01

FAR & Tenement Details (Table 4c-1)

Building	No. of Same Bldg	Total Built Up Area (Sq.mt.)	Proposed FAR Area (Sq.mt.)	Total FAR Area (Sq.mt.)	Total Consumed Additional FAR Area (Sq.mt.)	Tnmt (No.)
A (LALLU SINGH)	1	199.32	199.32	199.32	199.32	01
Grand Total :	1	199.32	199.32	199.32	199.32	01

Building USE/SUBUSE Details

Building Name	Building Use	Building SubUse	Building Structure
A (LALLU SINGH)	Residential	Bungalow/ Dwelling / Non Apartment	Non-Highrise

LTP NAME AND SIGNATURE	STRUCTURAL ENG'S NAME AND SIGNATURE	BUILDER NAME AND SIGNATURE	DIGITAL SIGNATURE
AMRIT KUMAR MAHATO CMC/DFTM/0004/2019			