

Proposal Basic Information	
Proposal File No.	CMC/BP/0131/W07/2021
Owner Name	ANITA DEVI
Khata No	267, 806
Plot No	3815, 3816
Village Name	Chas
Use	Residential
SubUse	Bungalow/ Dwelling / Non Apartment

AREA STATEMENT CHAS MUNICIPAL CORPORATION		VERSION NO. 1.0.60
PROJECT DETAIL:		VERSION DATE: 16/10/2020
Region: JHARKHAND URBAN LOCAL BODIES	Plot Use: Residential	
District: BOKARO	Plot SubUse: Bungalow/ Dwelling / Non Apartment	
Authority: CHAS MUNICIPAL CORPORATION	PlotNearbyReligiousStructure: NA	
Inward No: CMC/BP/0131/W07/2021	PlotSubPlot No: 3815, 3816	
Application Type: General Proposal	North: CTS No. - PART OF PLOT NO.-3815	
Project Type: Building Permission	South: Road Width - 4.5	
Nature of Development: New	East: CTS No. - LILAWATI DEVI	
Location of Development Area: New Area	West: Plot No. - PART OF PLOT 3815, 3816	
AREA DETAILS:		
AREA OF PLOT (Minimum)	(A)	SQ. MT. 195.00
Deduction for NetPlot Area		
Surrender Free of Cost		10.40
Total		10.40
NET AREA OF PLOT(Gross Plot Area - Deduction from Gross Plot area)	(A-Deductions)	184.60
Deduction for Balance Plot Area(from Gross Plot Area)		
Surrender Free of Cost		10.40
Common Plot		35.08
Total		45.48
BALANCE AREA OF PLOT(Net Plot Area - Recreational/Amenity space)	(A-Deductions)	149.52
PLOT AREA FOR COVERAGE(Net Plot Area)	(A-Deductions)	184.60
Plot Area for FAR (Net Plot Area + Road/Widening Area)	(A-Deductions)	195.00
COVERAGE CHECK		
Permissible Coverage area (70.00 %)		129.22
Proposed Coverage Area (55.70 %)		102.82
Total Prop. Coverage Area (55.7 %)		102.82
Balance coverage area (14.30 %)		26.40
FAR CHECK		
Perm. FAR Area (1.50)		292.50
Total Perm. FAR area		292.50
Residential FAR		205.64
Proposed FAR Area		205.64
Total Proposed FAR Area		205.64
Consumed FAR (Factor)		1.05
Balance FAR Area		86.86
BUILT UP AREA CHECK		
Total Proposed BuiltUp Area		205.64
ARCHITECT (Regd)	MANOJ KUMAR	
ENGINEER (Regd)		
SUPERVISOR (Regd)		
OWNER (Regd)	ANITA DEVI	
DEVELOPMENT AUTHORITY		LOCAL BODY

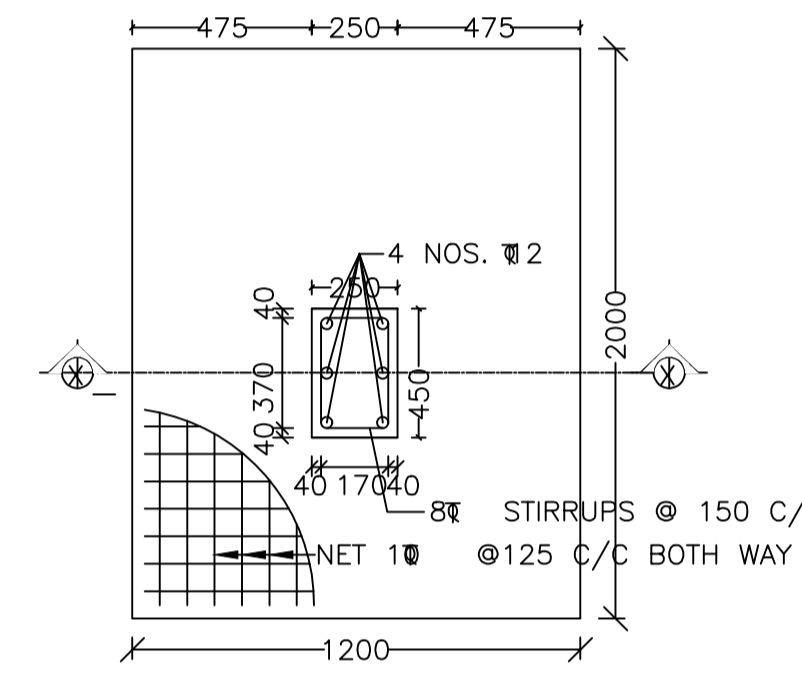
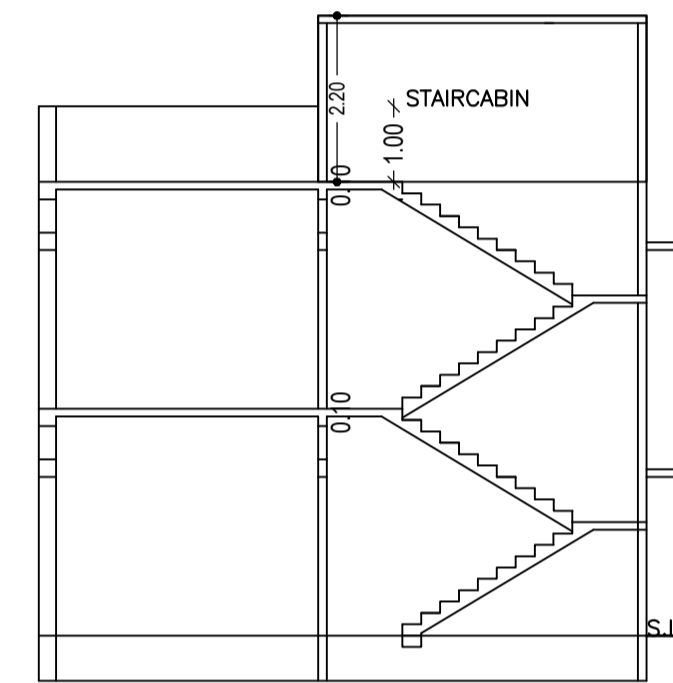
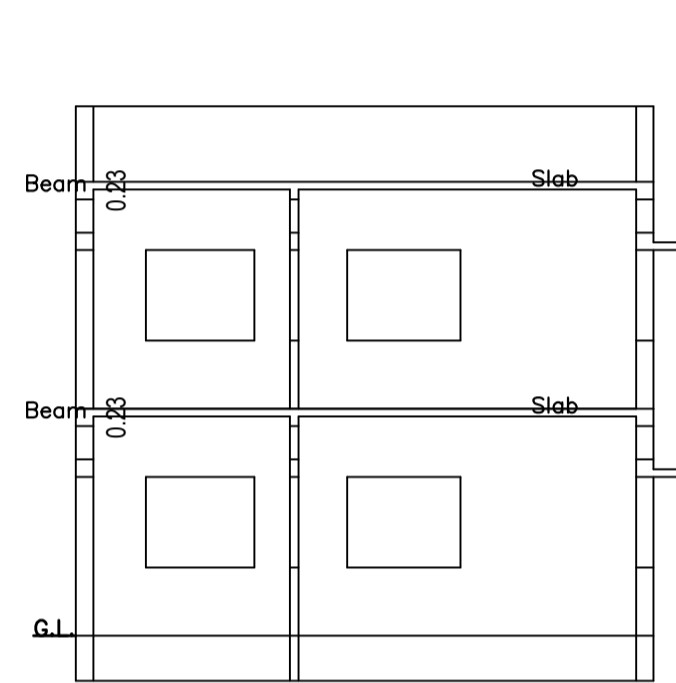
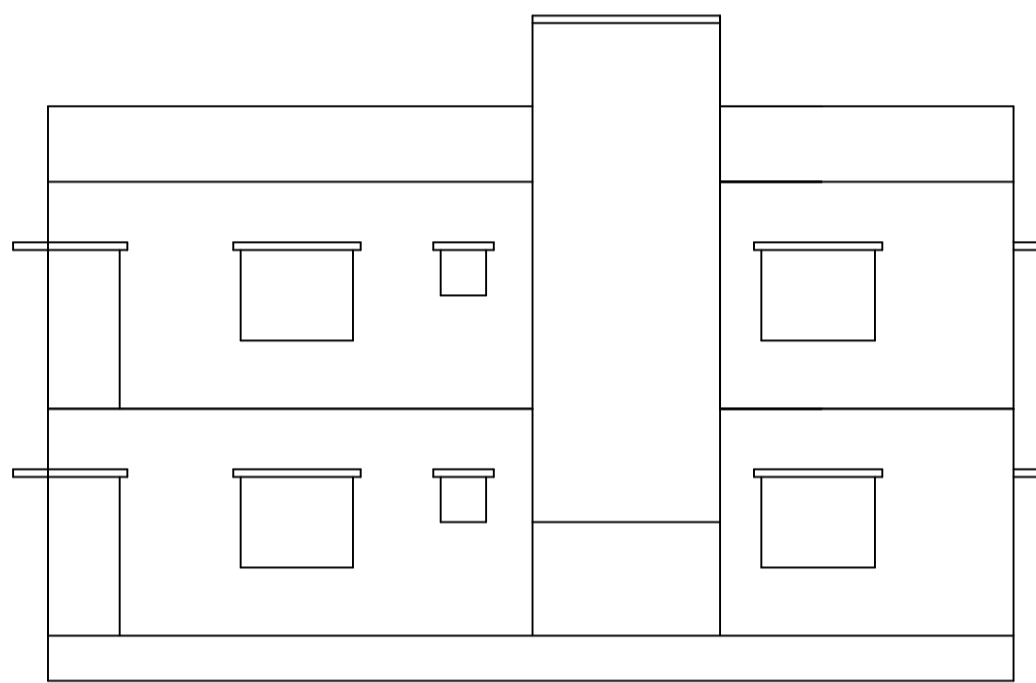
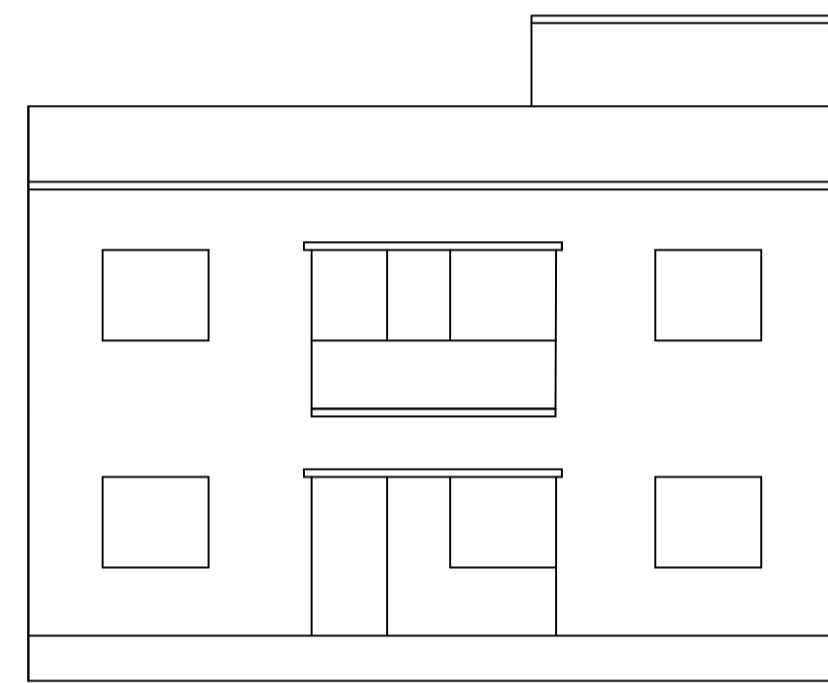

FRONT ELEVATION

SIDE ELEVATION

SECTION AT-AA

SECTION AT-BB

13.00 mt.

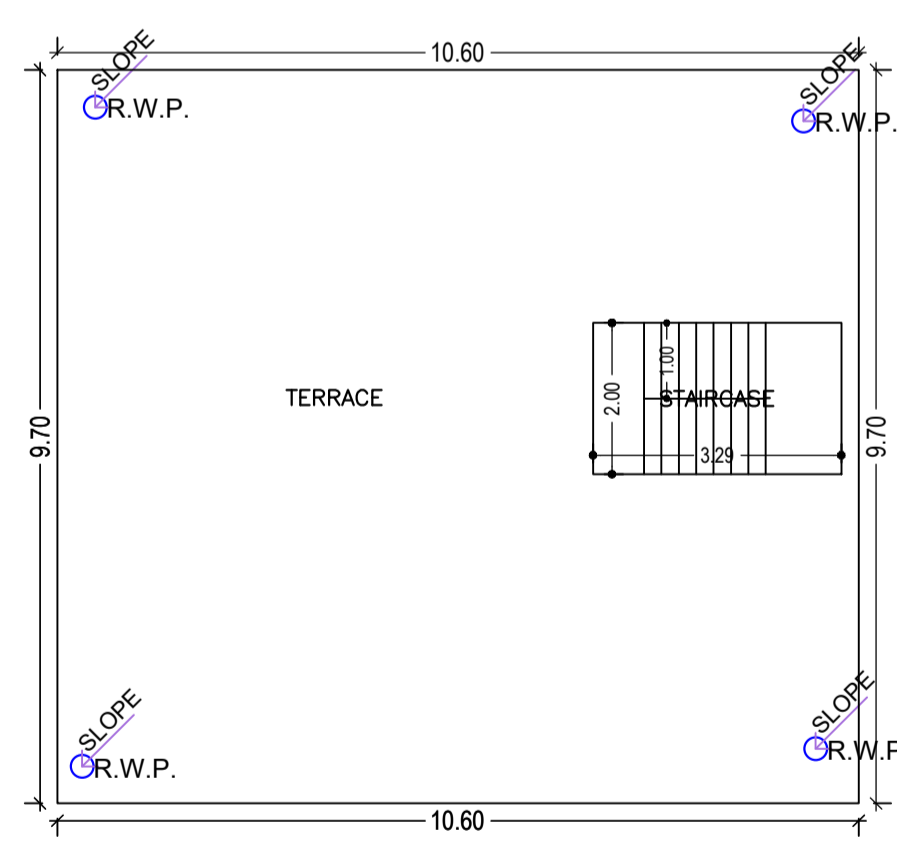
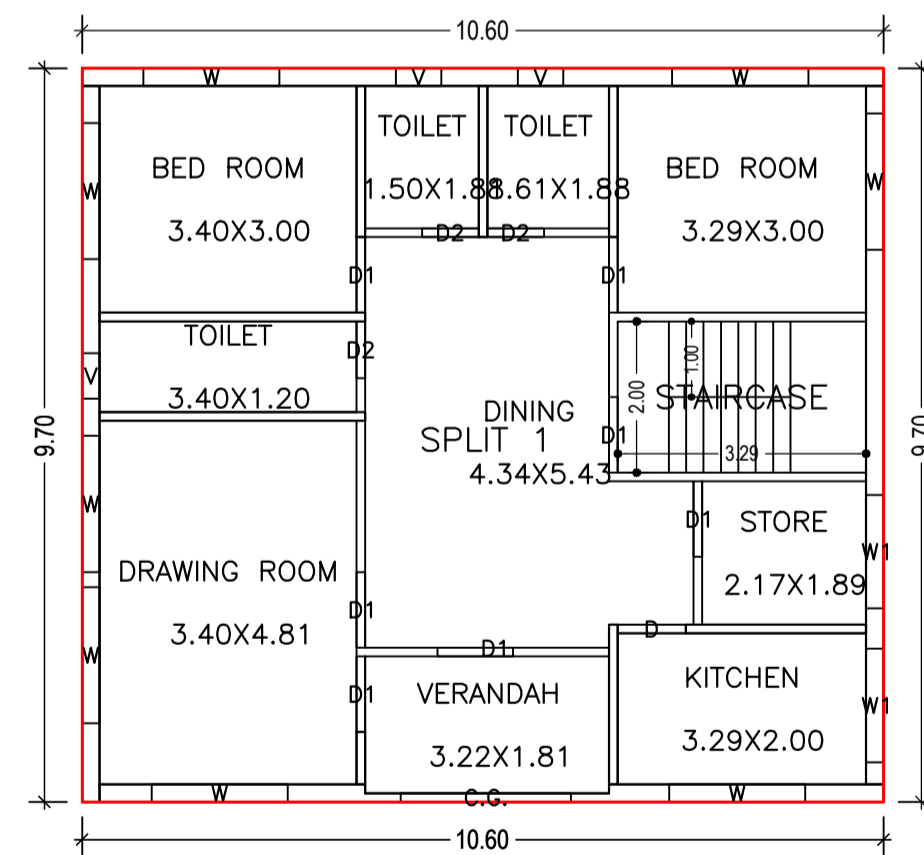
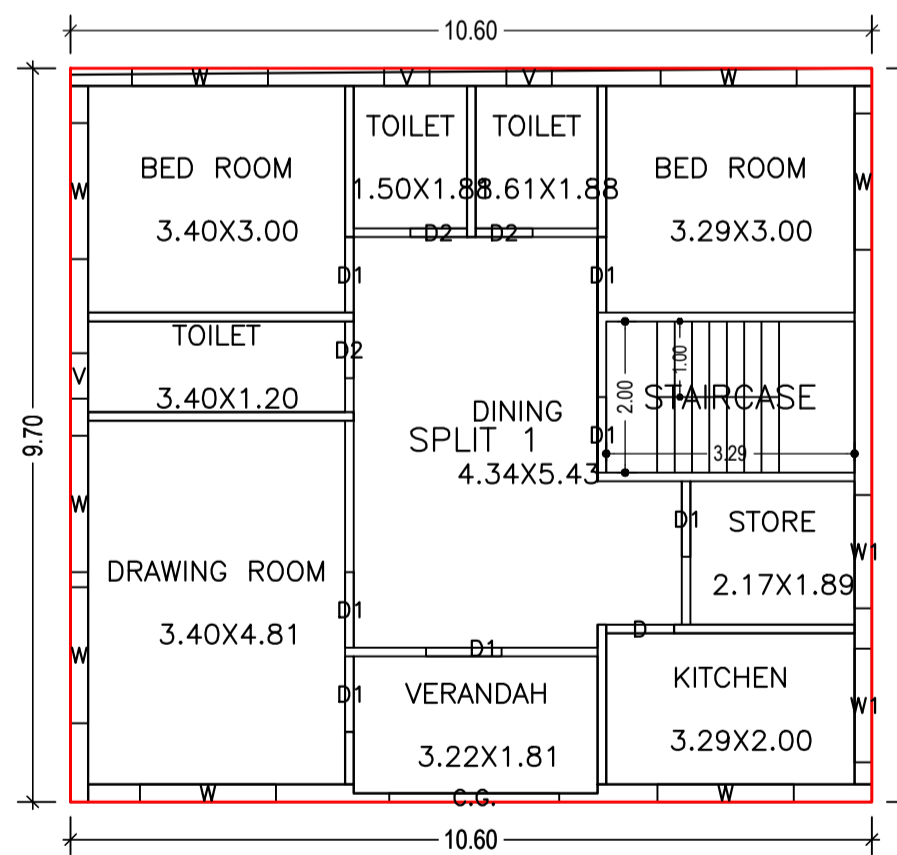

GROUND FLOOR PLAN (Proposed) (SCALE 1:100)

FIRST FLOOR PLAN (Proposed) (SCALE 1:100)

TERRACE FLOOR PLAN (SCALE 1:100)

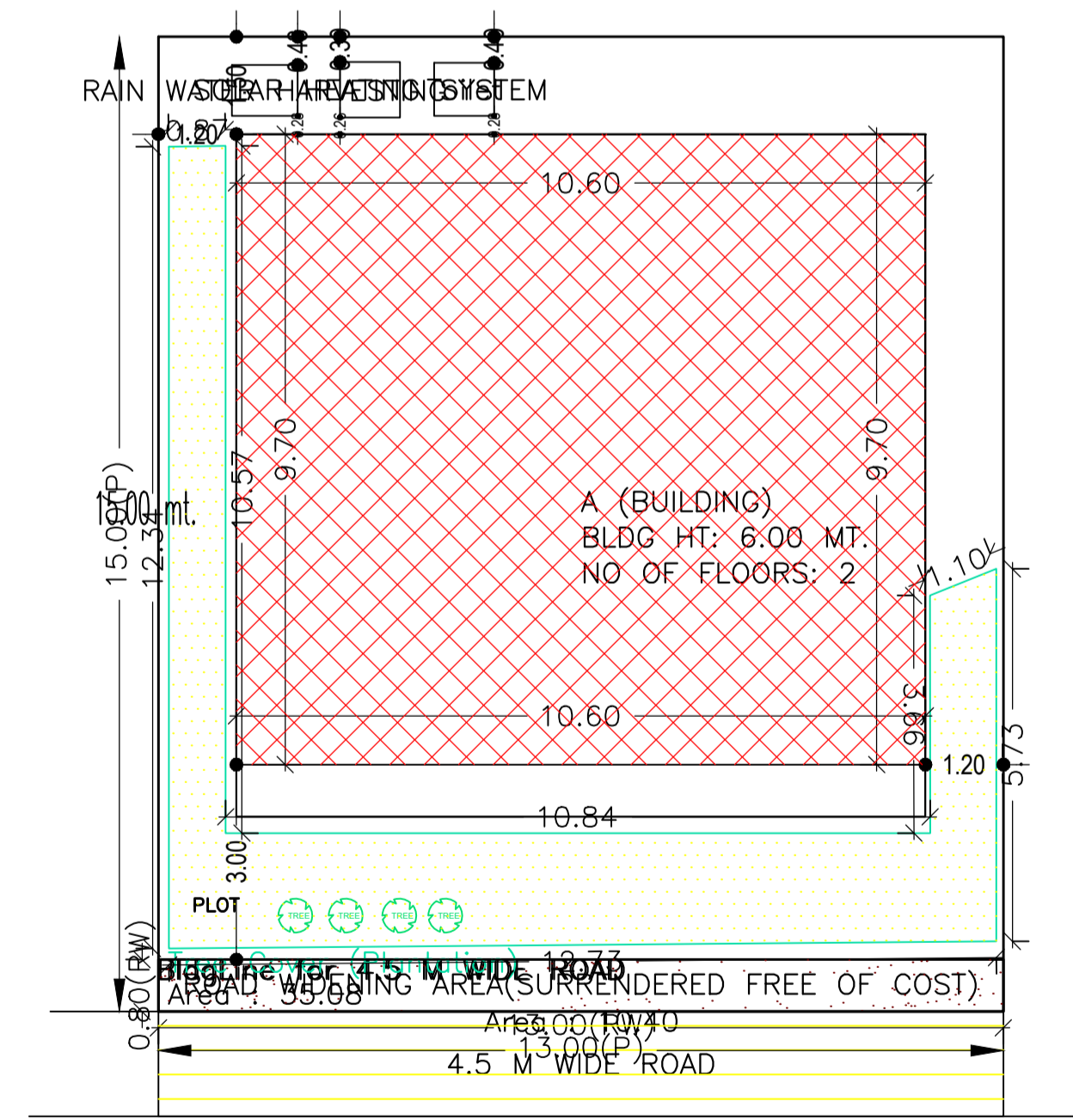

SITE PLAN

SITE PLAN

SCHEDULE OF DOOR:

BUILDING NAME	NAME	LENGTH	HEIGHT	NOS
A (BUILDING)	D2	0.75	2.10	06
A (BUILDING)	D	0.90	2.10	02
A (BUILDING)	D1	1.00	2.10	14
A (BUILDING)	C.G.	2.25	2.10	02

SCHEDULE OF WINDOW/VENTILATION:

BUILDING NAME	NAME	LENGTH	HEIGHT	NOS
A (BUILDING)	V	0.60	1.20	06
A (BUILDING)	W1	1.50	1.20	04
A (BUILDING)	W	1.80	1.20	16

Building :A (BUILDING)

Floor Name	Total Built Up Area (Sq.mt.)	Proposed FAR Area (Sq.mt.)	Total FAR Area (Sq.mt.)	Total Consumed Additional FAR Area (Sq.mt.)	Tnmt (No.)
Ground Floor	102.82	102.82	102.82	102.82	01
First Floor	102.82	102.82	102.82	102.82	00
Terrace Floor	0.00	0.00	0.00	0.00	00
Total :	205.64	205.64	205.64	205.64	01
Total Number of Same Buildings :	1				
Total :	205.64	205.64	205.64	205.64	01

Buildingwise Floor FAR Details

Floor Name	Building Name A (BUILDING)		Total	
	Proposed Built Up Area (Sq.mt.)	Proposed FAR Area (Sq.mt.)	Total Proposed Built Up Area (Sq.mt.)	Total FAR Area (Sq.mt.)
Ground Floor	102.82	102.82	102.82	102.82
First Floor	102.82	102.82	102.82	102.82
Terrace Floor	0.00	0.00	0.00	0.00
Total :	205.64	205.64	205.64	205.64

FAR & Tenement Details (Table 4c-1)

Building	No. of Same Bldg	Total Built Up Area (Sq.mt.)	Proposed FAR Area (Sq.mt.)	Total FAR Area (Sq.mt.)	Total Consumed Additional FAR Area (Sq.mt.)	Tnmt (No.)
A (BUILDING)	1	205.64	205.64	205.64	205.64	01
Grand Total :	1	205.64	205.64	205.64	205.64	01

UnitBUA Table for Building :A (BUILDING)

FLOOR	Name	UnitBUA Type	UnitBUA Area	Carpet Area	No. of Rooms	No. of Tenement
GROUND FLOOR PLAN	SPLIT 1	FLAT	172.96	168.77	10	1
FIRST FLOOR PLAN	SPLIT 1	FLAT	0.00	0.00	10	0
Total:	-	-	172.96	168.77	20	1

COLOR INDEX

PLOT BOUNDARY	Black
ABUTTING ROAD	Green
PROPOSED CONSTRUCTION	Red
COMMON PLOT	Yellow
ROAD WIDENING AREA	Blue
EXISTING (To be retained)	Light Blue
EXISTING (To be demolished)	Dark Blue

LTP NAME AND SIGNATURE

MANOJ KUMAR
CMC/SUP/0016/2018

STRUCTURAL ENG'S NAME AND SIGNATURE

BUILDER NAME AND SIGNATURE

DIGITAL SIGNATURE

Building USE/SUBUSE Details

Building Name	Building Use	Building SubUse	Building Structure
A (BUILDING)	Residential	Residential Bldg/Apartment	Non-Highrise