

Proposal Basic Information

Proposal File No.	CMC/BP/0325/W07/2021
Owner Name	DEEPAK NANDI
Khata No	724
Plot No	3464
Village Name	Chas
Use	Residential
SubUse	Bungalow/ Dwelling / Non Apartment

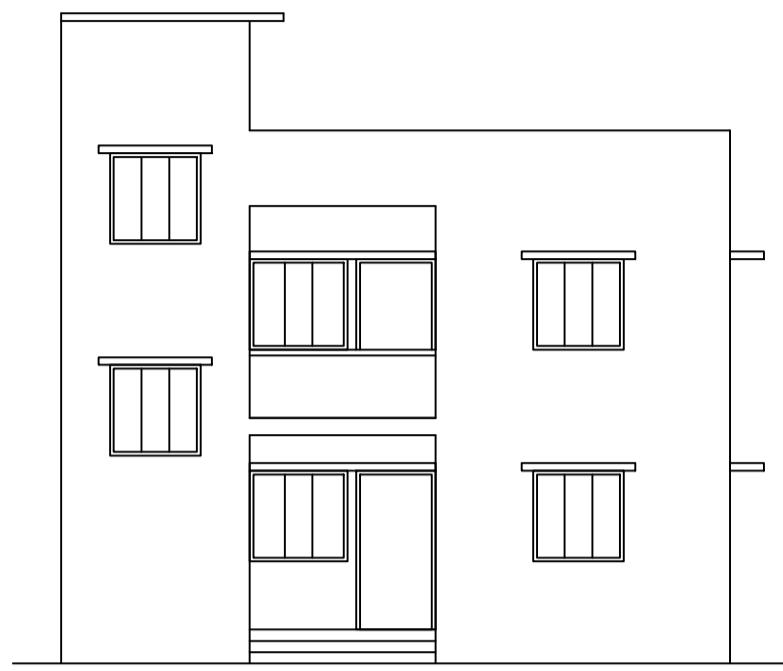

FRONT ELEVATION

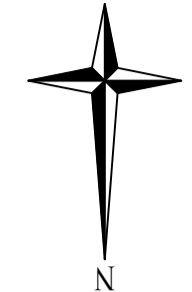
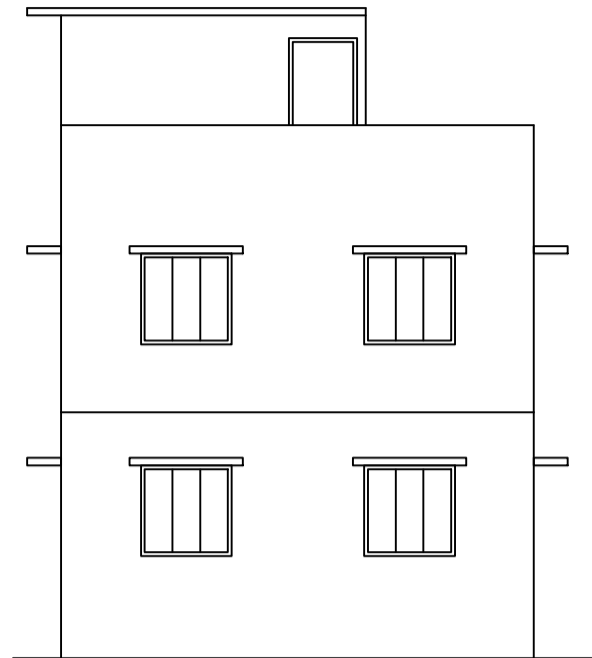

SIDE ELEVATION

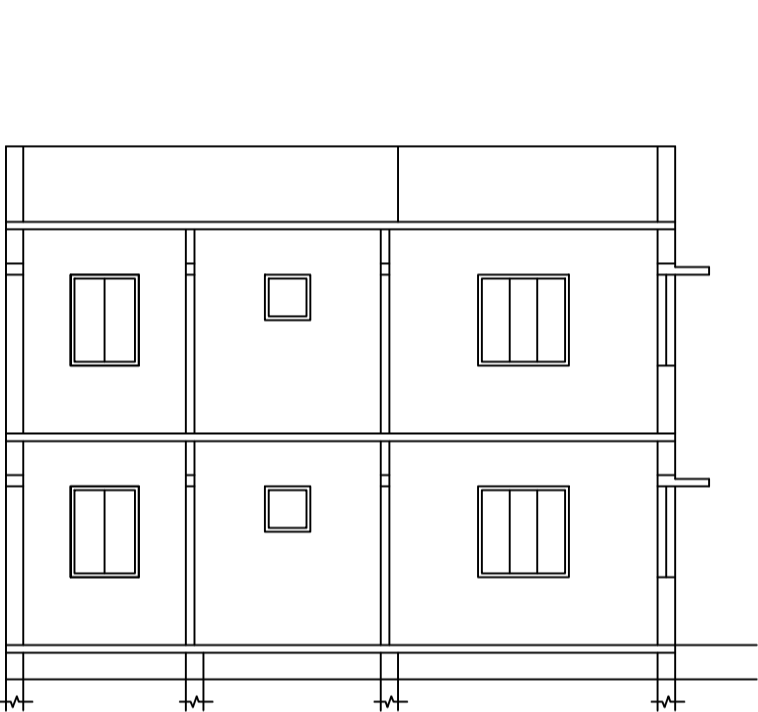
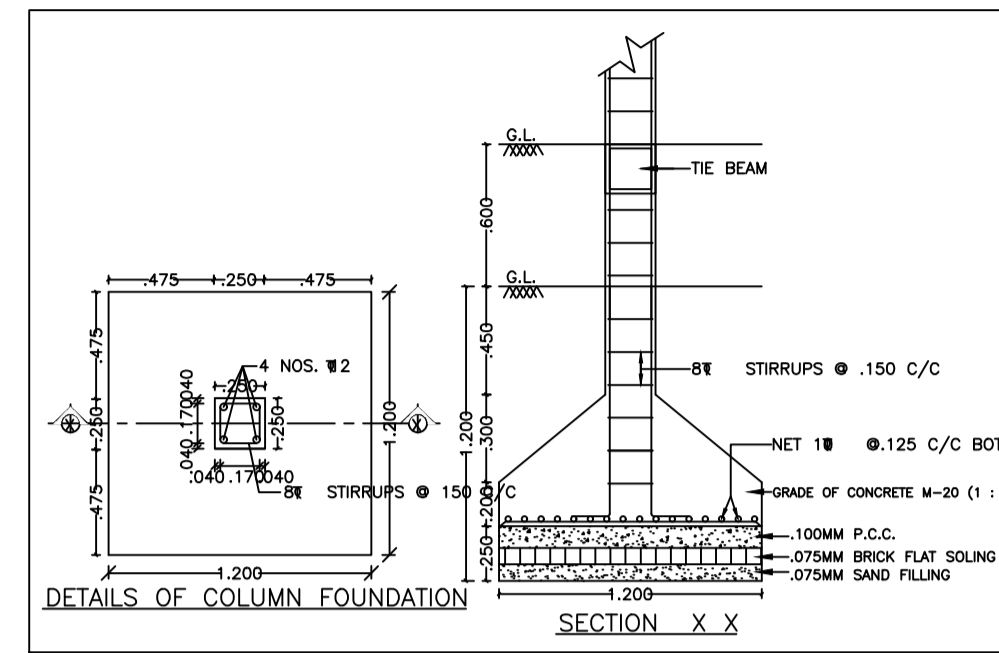
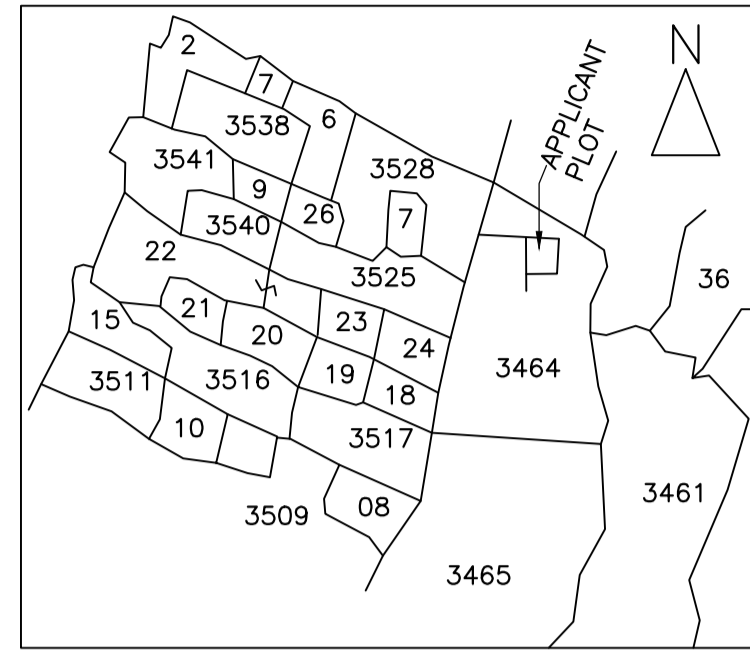

SECTION AT A A

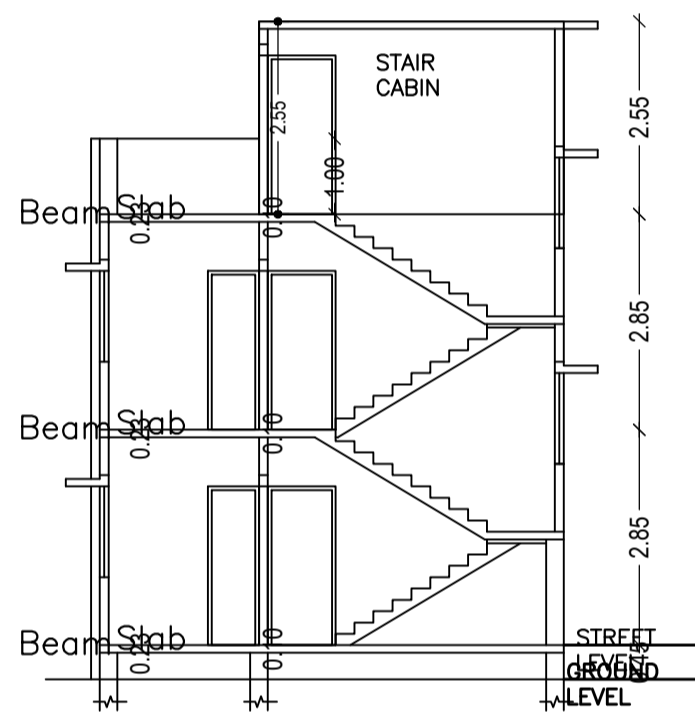

SECTION AT B B

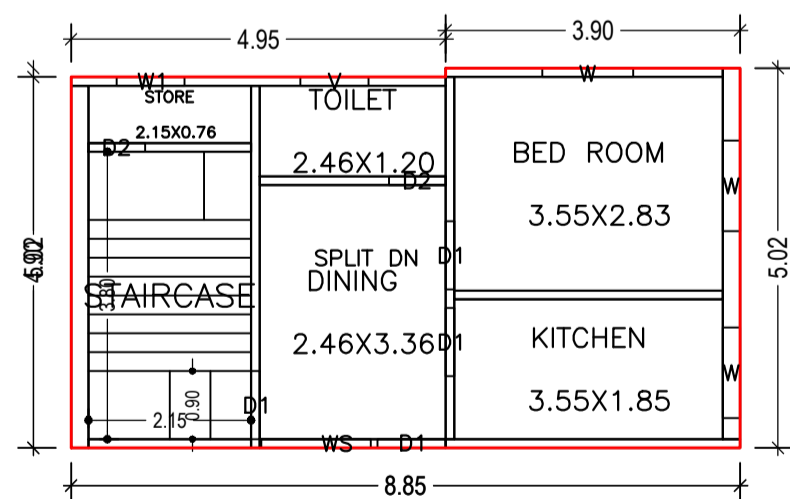
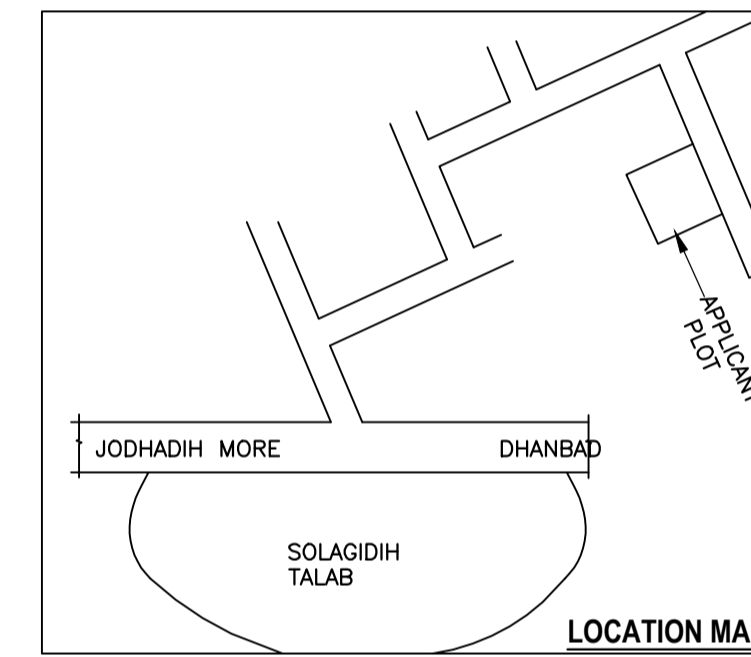
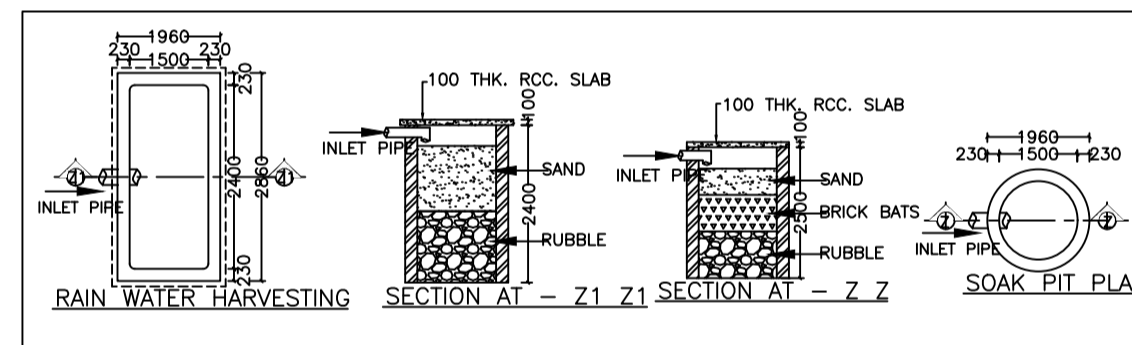
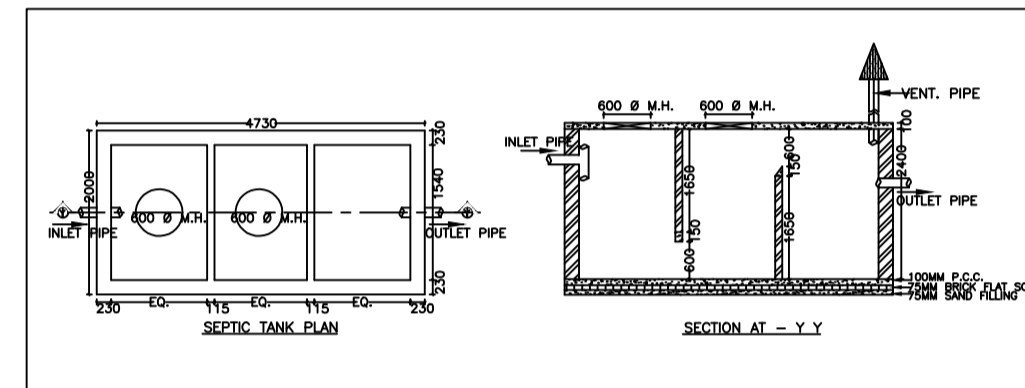

GROUND FLOOR PLAN (Proposed) (SCALE 1:100)

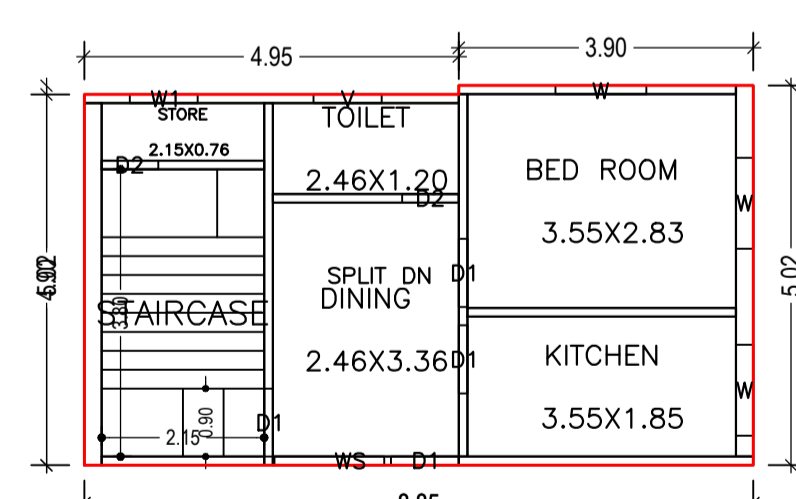

FIRST FLOOR PLAN (Proposed) (SCALE 1:100)

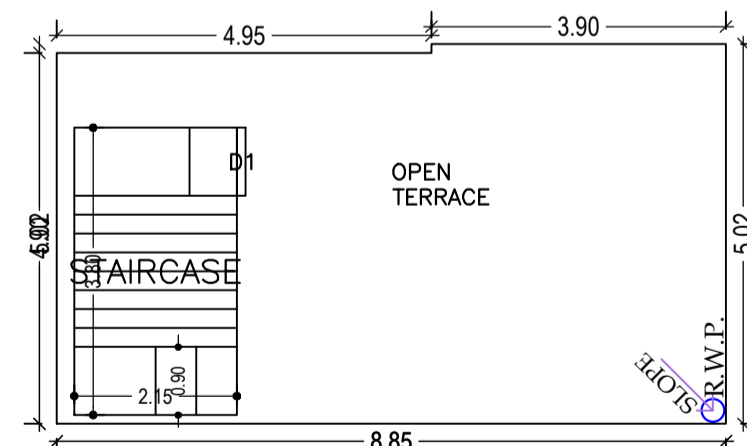

TERRACE FLOOR PLAN (SCALE 1:100)

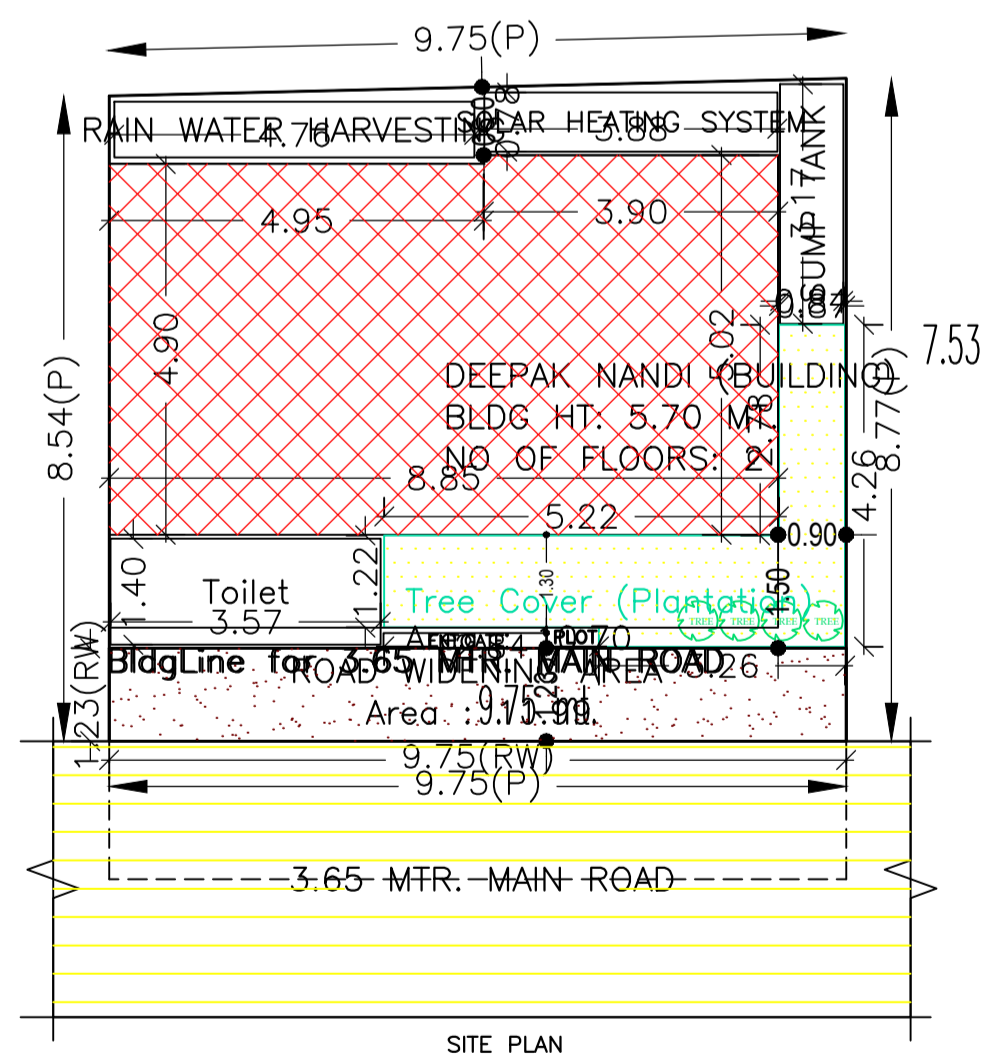

SITE PLAN

AREA STATEMENT CHAS MUNICIPAL CORPORATION	VERSION NO. : 1.0.64
PROJECT DETAIL:	VERSION DATE: 16/10/2020
Region: JHARKHAND URBAN	Plot Use: Residential
District: BOKARO	Plot SubUse: Bungalow/ Dwelling / Non Apartment
Authority: CHAS MUNICIPAL CORPORATION	Plot/Neary/Religious/Structure: NA
Inward No: CMC/BP/0325/W07/2021	Plot/SubPlot No: 3464
Application Type: General Proposal	North: Road Width - 3.65
Project Type: Building Permission	South: CTS No. - PART OF PLOT
Nature of Development: New	East: CTS No. - HARJU SEN
Location of Development Area: New Area	West: CTS No. - 5 FEET WADE GALLI
AREA DETAILS	
AREA OF PLOT (Minimum)	84.34 SQ.MT.
Deduction for NetPlot Area	
Road Widening Area	11.99
NET AREA OF PLOT(Gross Plot Area - Deduction from Gross Plot area)	72.35 (A-Deductions)
Deduction for Balance Plot Area(from Gross Plot Area)	
Road Widening Area	11.99
Common Plot	10.70
Total	22.69
BALANCE AREA OF PLOT(Net Plot Area - Recreational/Amenity space)	61.65 (A-Deductions)
PLOT AREA FOR COVERAGE(Net Plot Area)	72.35 (A-Deductions)
Plot Area for FAR (Net Plot Area + RoadWidening Area)	72.35 (A-Deductions)
COVERAGE CHECK	
Permissible Coverage area (70.00 %)	50.64
Proposed Coverage Area (60.63 %)	43.86
Total Prop. Coverage Area(60.63 %)	43.86
Balance coverage area (9.37 %)	6.78
FAR CHECK	
Perm. FAR Area (1.50)	108.52
Total Perm. FAR area	108.52
Residential FAR	87.73
Proposed FAR Area	87.73
Total Proposed FAR Area	87.73
Consumed FAR (Factor)	1.21
Balance FAR Area	20.79
BUILT UP AREA CHECK	
Total Proposed BuiltUp Area	87.72
ARCHITECT (Regd)	Mukesh Kumar
ENGINEER (Regd)	
SUPERVISOR (Regd)	
OWNER (Regd)	DEEPAK NANDI
DEVELOPMENT AUTHORITY LOCAL BODY	

SCHEDULE OF DOOR:

BUILDING NAME	NAME	LENGTH	HEIGHT	NOS
DEEPAK NANDI (BUILDING)	D2	0.75	2.10	04
DEEPAK NANDI (BUILDING)	D1	0.90	2.10	08

SCHEDULE OF WINDOW/VENTILATION:

BUILDING NAME	NAME	LENGTH	HEIGHT	NOS
DEEPAK NANDI (BUILDING)	V	0.90	0.45	02
DEEPAK NANDI (BUILDING)	W1	0.90	1.20	02
DEEPAK NANDI (BUILDING)	W	1.20	1.20	06
DEEPAK NANDI (BUILDING)	WS	1.45	1.20	02

Building :DEEPAK NANDI (BUILDING)

Floor Name	Total Built Up Area (Sq.mt.)	Proposed FAR Area (Sq.mt.) Resi.	Total FAR Area (Sq.mt.)	Total Consumed Additional FAR Area (Sq.mt.)	Tnmt (No.)
Ground Floor	43.86	43.86	43.86	43.86	01
First Floor	43.86	43.86	43.86	43.86	00
Terrace Floor	0.00	0.00	0.00	0.00	00
Total :	87.72	87.72	87.72	87.72	01
Total Number of Same Buildings :	1				
Total :	87.72	87.72	87.72	87.72	01

Buildingwise Floor FAR Details

Floor Name	Building Name DEEPAK NANDI (BUILDING)		Total	
	Proposed Built Up Area (Sq.mt.)	Proposed FAR Area (Sq.mt.)	Total Proposed Built Up Area (Sq.mt.)	Total FAR Area (Sq.mt.)
Ground Floor	43.86	43.86	43.86	43.86
First Floor	43.86	43.86	43.86	43.86
Terrace Floor	0.00	0.00	0.00	0.00
Total :	87.72	87.72	87.72	87.72

Building USE/SUBUSE Details

Building Name	Building Use	Building SubUse	Building Structure
DEEPAK NANDI (BUILDING)	Residential	Bungalow/ Dwelling / Non Apartment	Non-Highrise

UnitBUA Table for Building :DEEPAK NANDI (BUILDING)

FLOOR	Name	UnitBUA Type	UnitBUA Area	Carpet Area	No. of Rooms	No. of Tenement
GROUND FLOOR PLAN	SPLIT DN	FLAT	87.73	75.24	5	1
FIRST FLOOR PLAN	SPLIT DN	FLAT	0.00	0.00	5	0
Total:	-	-	87.73	75.24	10	1

FAR & Tenement Details (Table 4c-1)

Building	No. of Same Bldg	Total Built Up Area (Sq.mt.)	Proposed FAR Area (Sq.mt.) Resi.	Total FAR Area (Sq.mt.)	Total Consumed Additional FAR Area (Sq.mt.)	Tnmt (No.)
DEEPAK NANDI (BUILDING)	1	87.72	87.72	87.72	87.72	01
Grand Total :	1	87.72	87.72	87.72	87.72	01

COLOR INDEX

PLOT BOUNDARY	Black
ABUTTING ROAD	Red
PROPOSED CONSTRUCTION	Green
COMMON PLOT	Blue
ROAD WIDENING AREA	Yellow
EXISTING (To be retained)	Orange
EXISTING (To be demolished)	Purple

LTP NAME AND SIGNATURE: Mukesh Kumar, CMC/ENG/0004/2017

STRUCTURAL ENG'S NAME AND SIGNATURE: _____
 BUILDER NAME AND SIGNATURE: _____
 DIGITAL SIGNATURE: _____