

Proposal Basic Information

Proposal File No.	CMC/BP/0286/W30/2021
Owner Name	SATYENDRA SHARMA
Khata No	58
Plot No	168
Village Name	Bandhgora
Use	Residential
SubUse	Bungalow/ Dwelling / Non Apartment

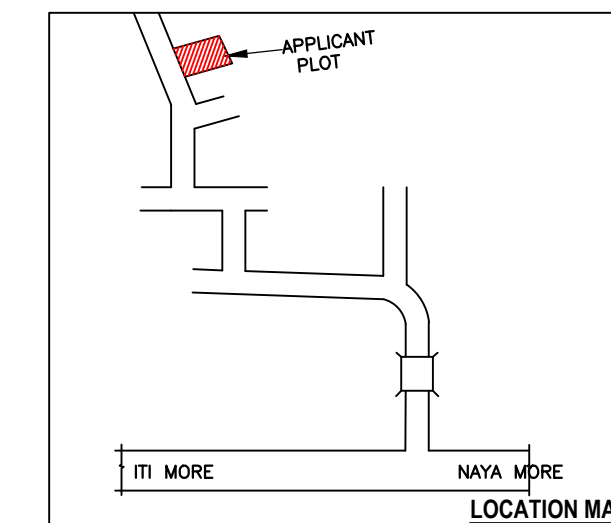

AREA STATEMENT CHAS MUNICIPAL CORPORATION	VERSION NO: 1.0.61		
	VERSION DATE: 16/10/2020		
PROJECT DETAIL:			
Region: JHARKHAND URBAN LOCAL BODIES	Plot Use: Residential		
District: BOKARO	Plot SubUse: Bungalow/ Dwelling / Non Apartment		
Authority: CHAS MUNICIPAL CORPORATION	PlotNearbyReligiousStructure: NA		
Inward No: CMC/BP/0286/W30/2021	PlotSubPlot No: 168		
Application Type: General Proposal	North: CTS No. - RART OF PLOT MARK A1		
Project Type: Building Permission	South: CTS No. - RART OF PLOT MARK A3		
Nature of Development: New	East: Road Width - 6.1		
Location of Development Area: New Area	West: CTS No. - RART OF LAND		
AREA DETAILS:			
AREA OF PLOT (Minimum)	(A)	SQ. MT.	222.48
NET AREA OF PLOT(Gross Plot Area - Deduction from Gross Plot area)	(A-Deductions)		222.48
Deduction for Balance Plot Area(from Gross Plot Area)			
Common Plot			48.28
Total			48.28
BALANCE AREA OF PLOT(Net Plot Area - Recreational/Amenity space)	(A-Deductions)		174.20
PLOT AREA FOR COVERAGE(Net Plot Area)	(A-Deductions)		222.48
Plot Area for FAR (Net Plot Area + Road Widening Area)	(A-Deductions)		222.48
COVERAGE CHECK			
Permissible Coverage area (70.00 %)			155.74
Proposed Coverage Area (59.01 %)			131.28
Total Prop. Coverage Area (59.01 %)			131.28
Balance coverage area (10.99 %)			24.46
FAR CHECK			
Perm. FAR Area (2.00)			444.96
Total Perm. FAR area			444.96
Residential FAR			262.56
Proposed FAR Area			262.56
Total Proposed FAR Area			262.56
Consumed FAR (Factor)			1.18
Balance FAR Area			182.40
BUILT UP AREA CHECK			
Total Proposed BuiltUp Area			262.56
ARCHITECT (Regd)			Mukesh Kumar
ENGINEER (Regd)			
SUPERVISOR (Regd)			SATYENDRA SHARMA
OWNER (Regd)			
DEVELOPMENT AUTHORITY		LOCAL BODY	

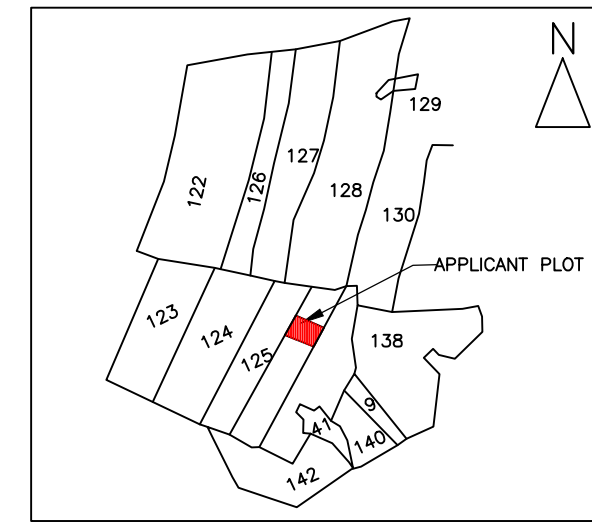
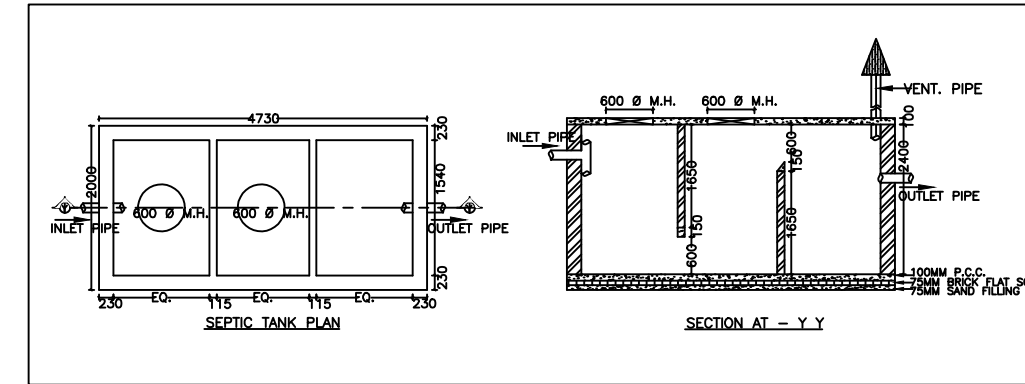
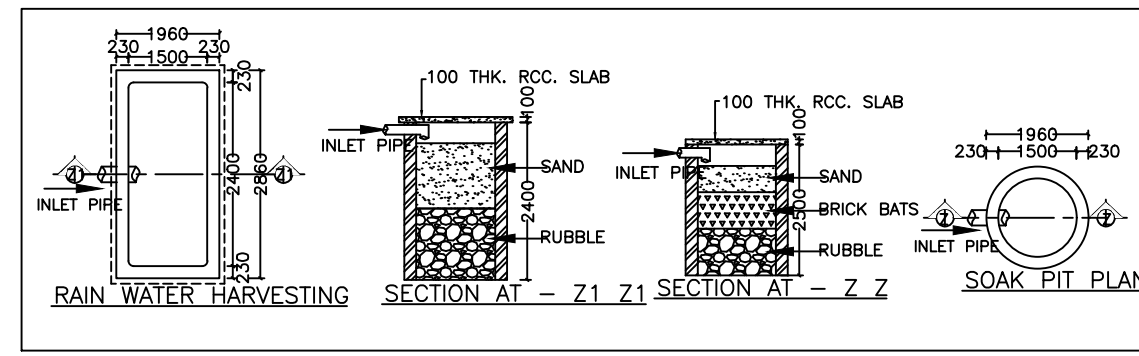
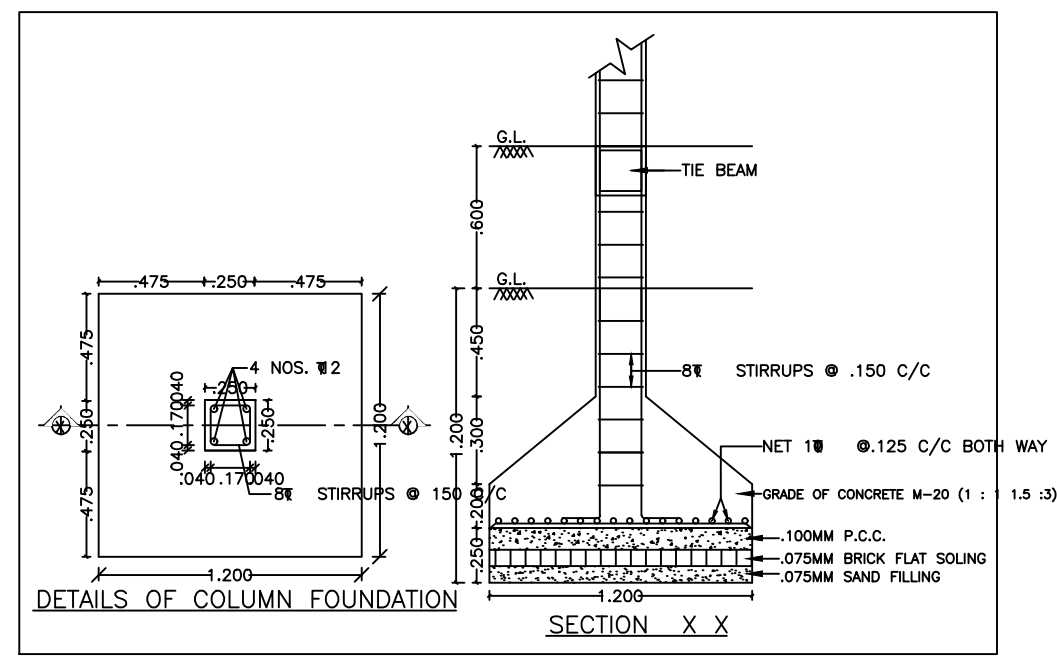
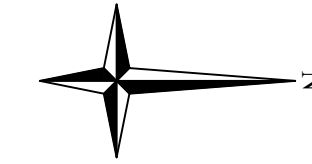
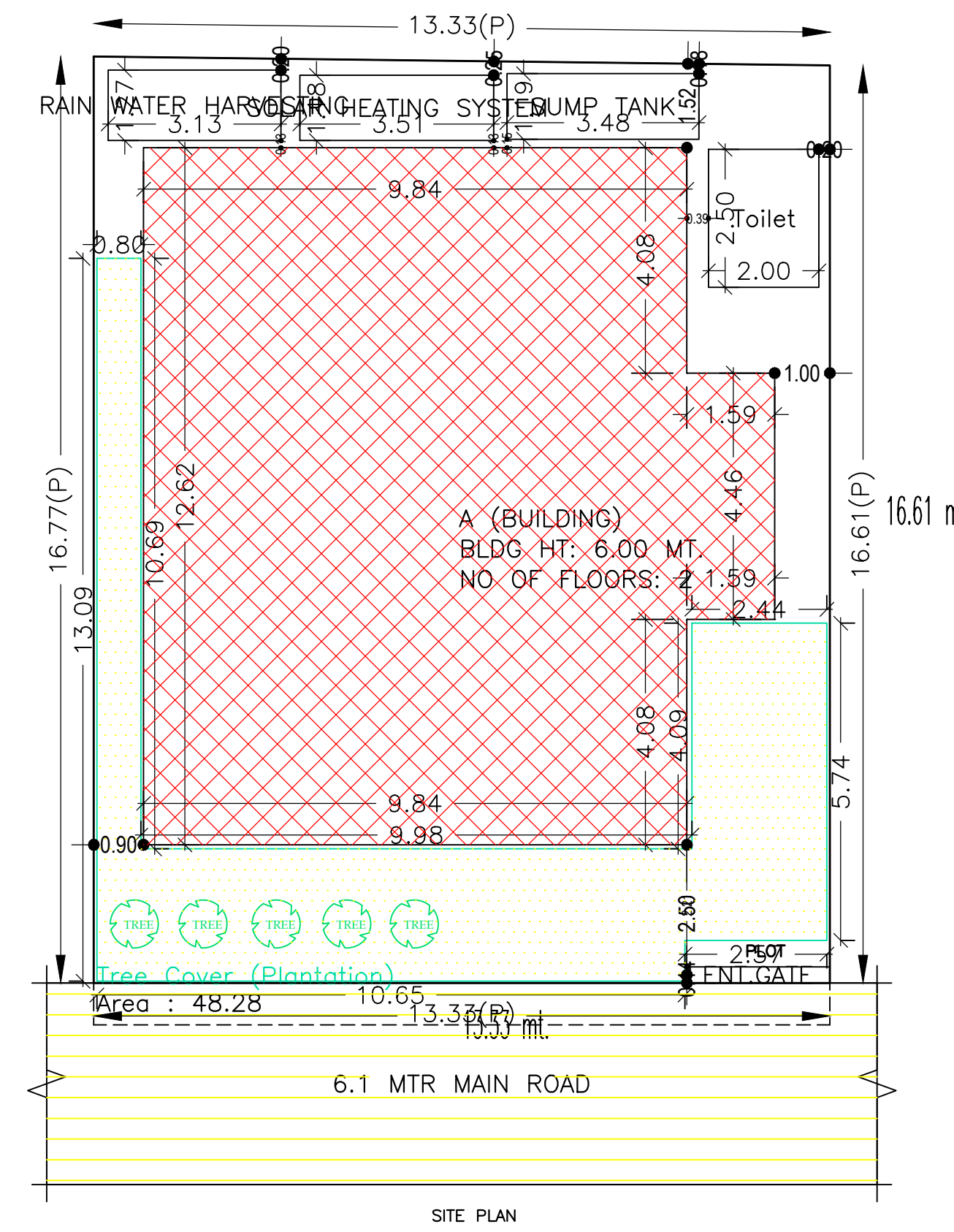
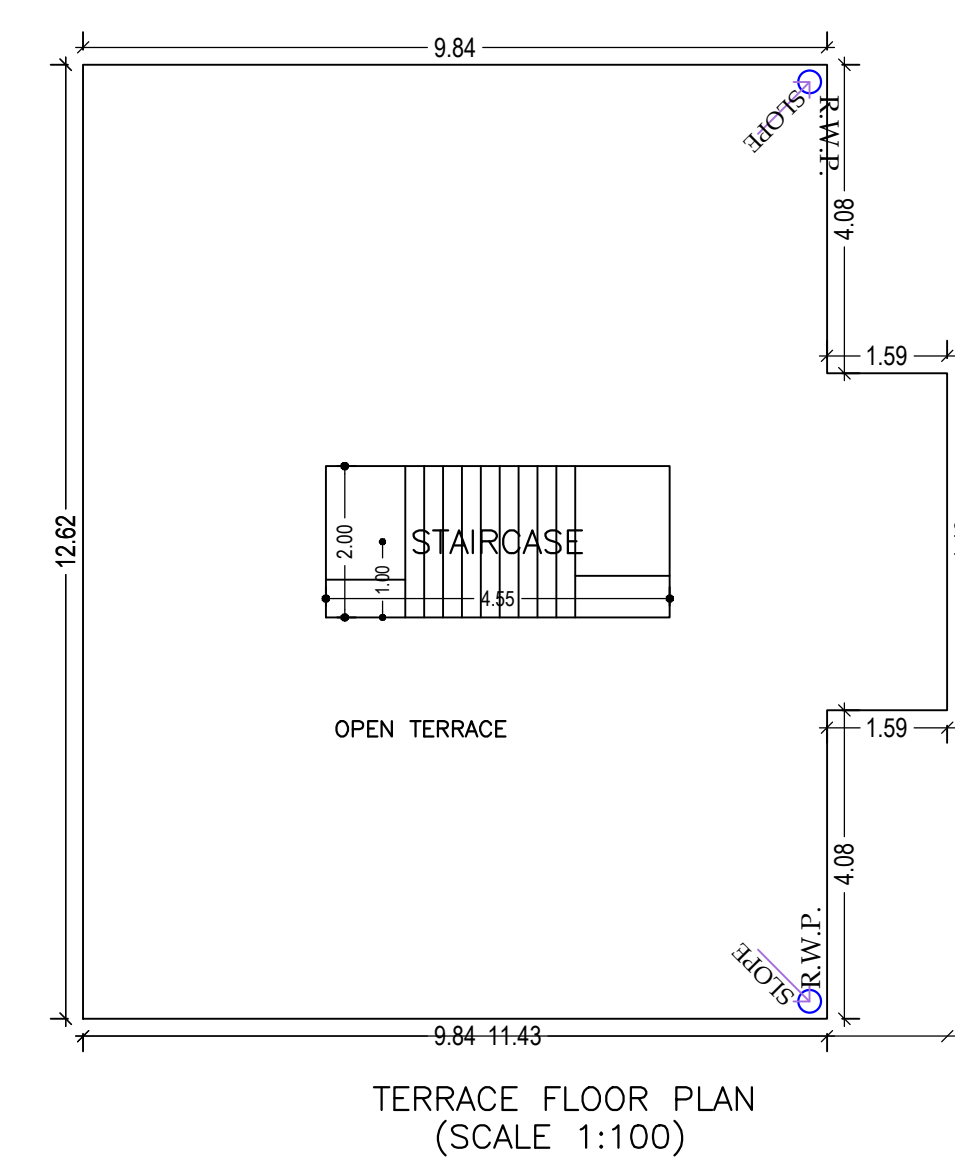
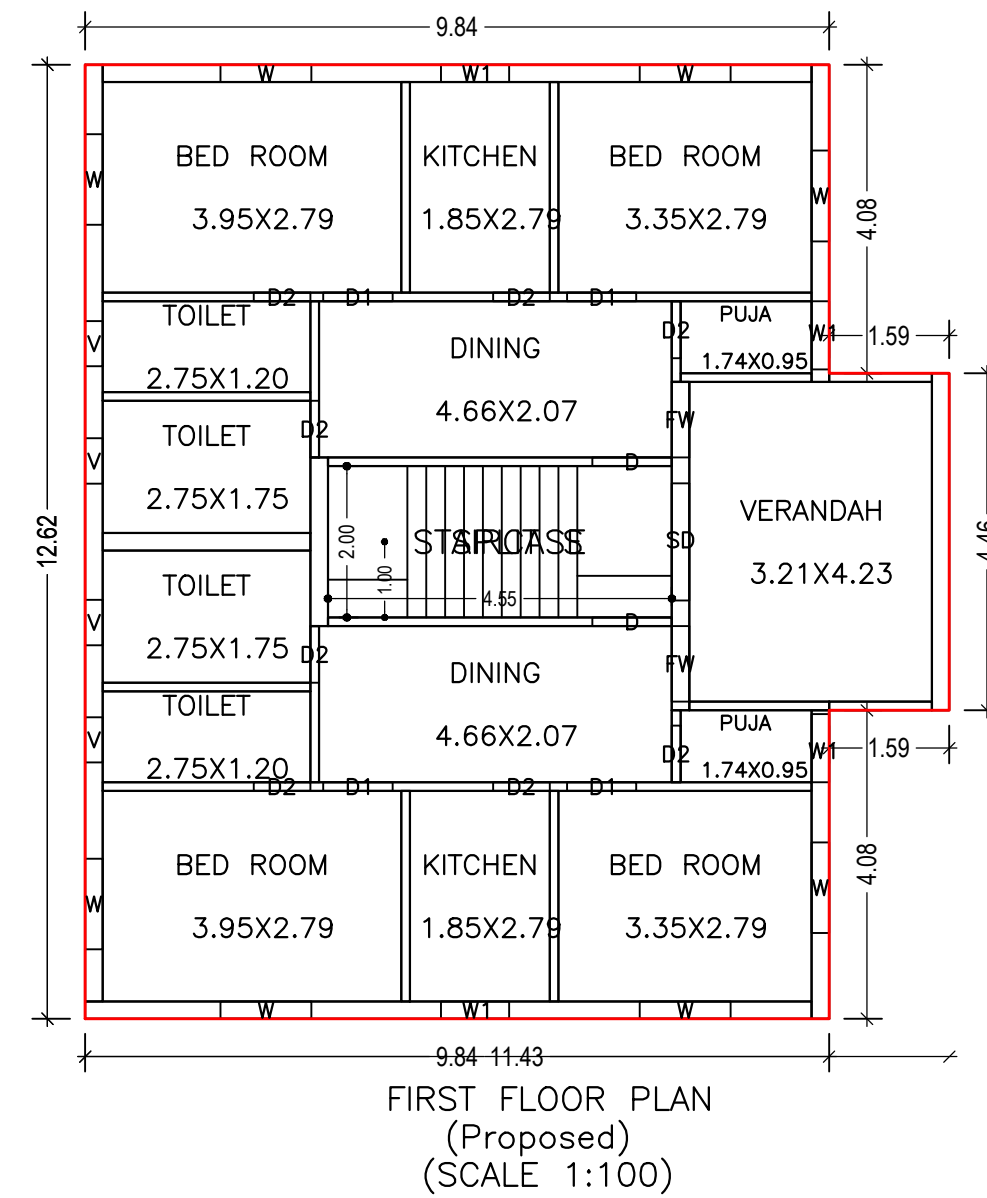
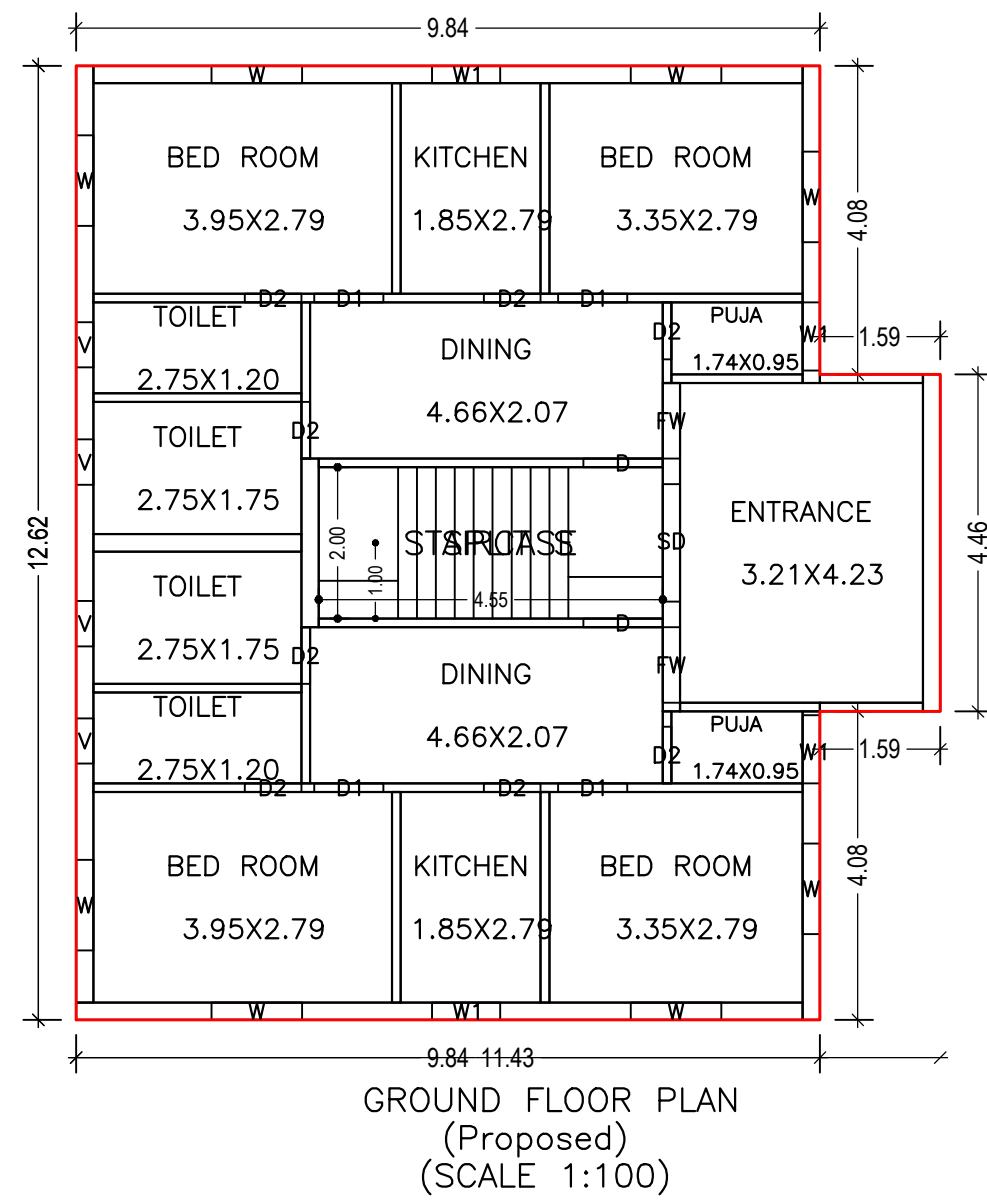
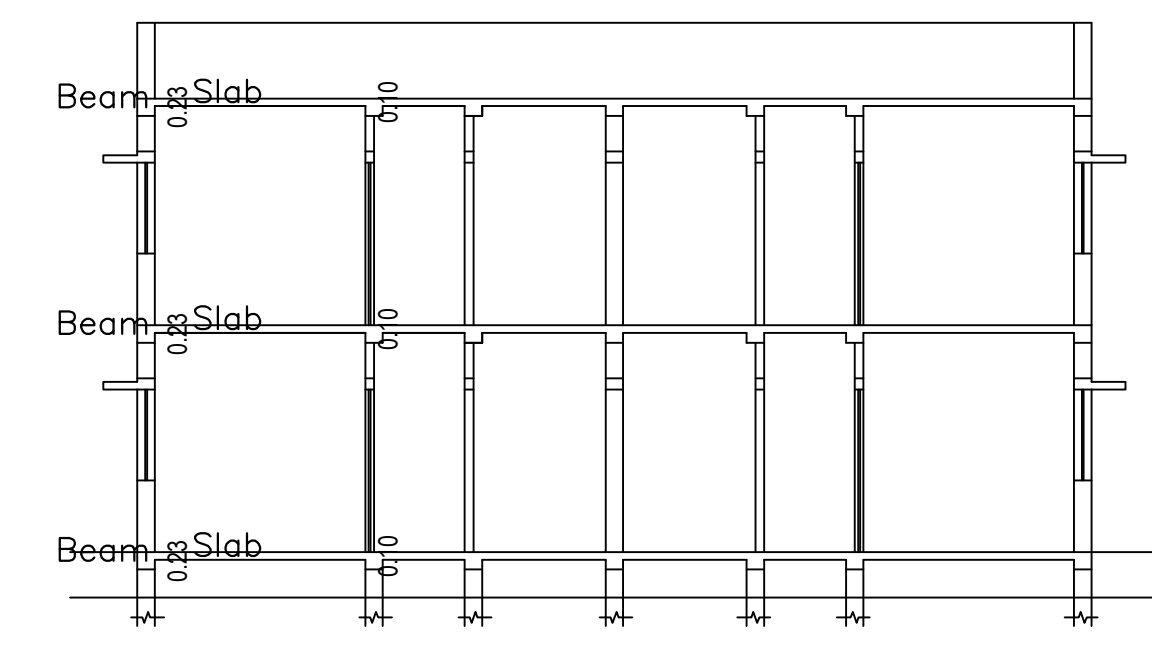
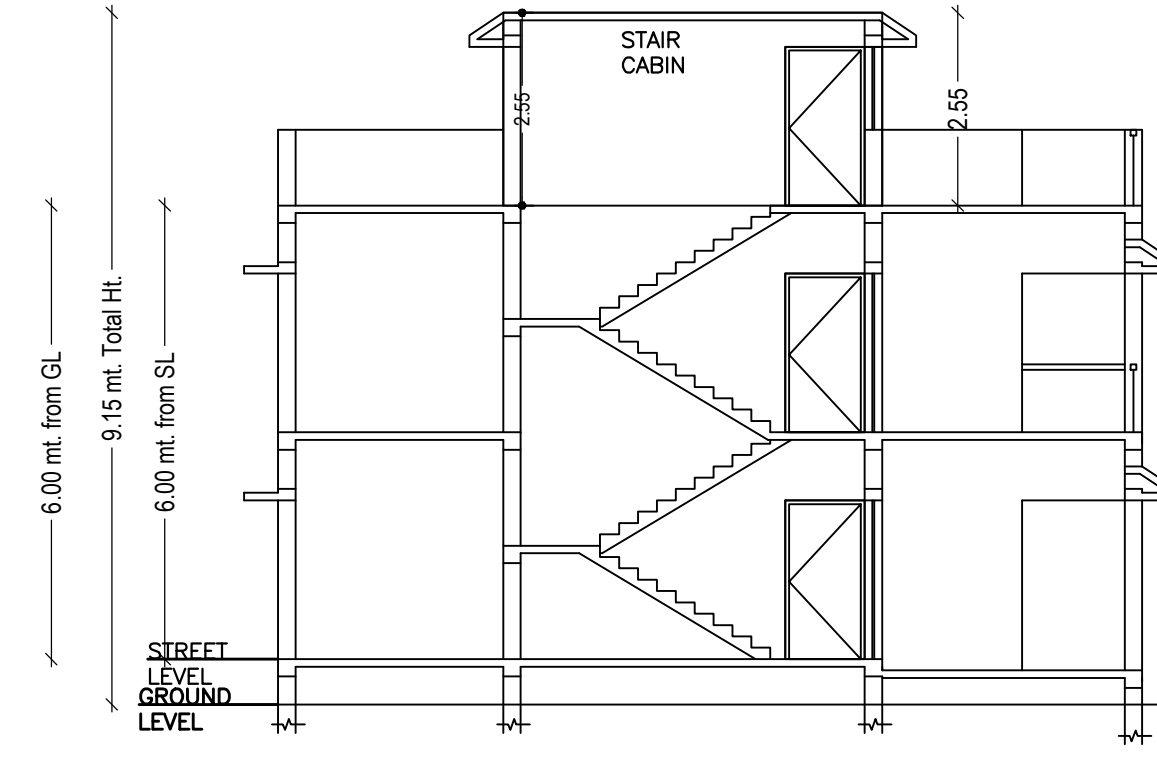
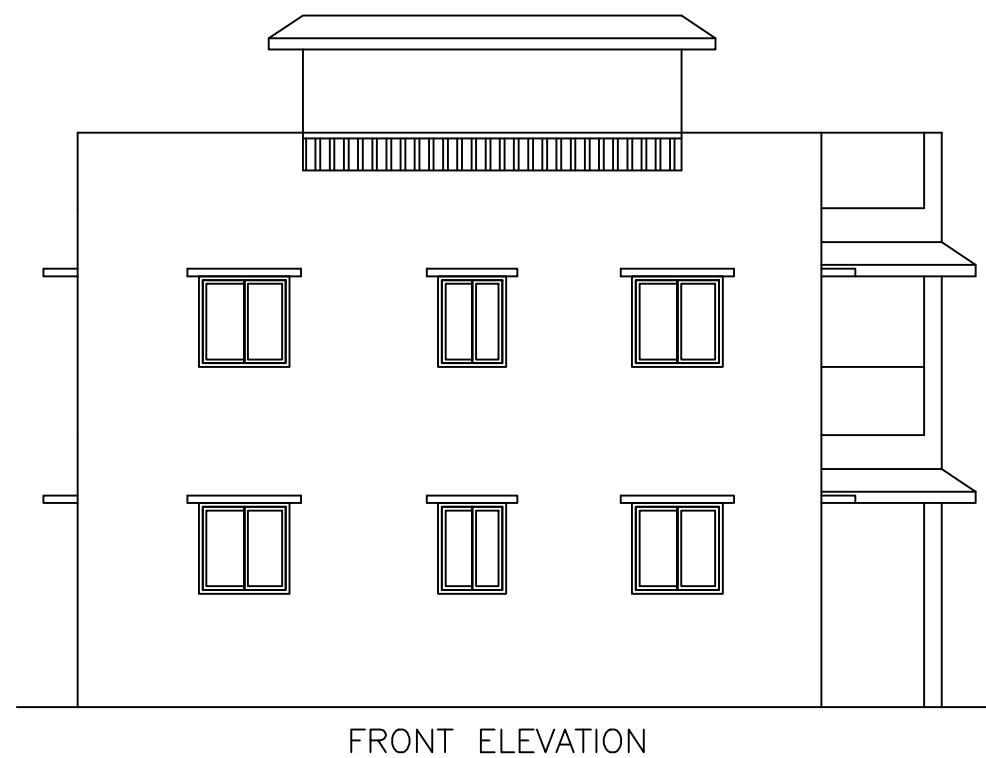

SCHEDULE OF DOOR:				
BUILDING NAME	NAME	LENGTH	HEIGHT	NOS
A (BUILDING)	D2	0.75	2.10	16
A (BUILDING)	D1	0.92	2.10	08
A (BUILDING)	D	1.05	2.10	04
A (BUILDING)	SD	1.55	2.10	02
SCHEDULE OF WINDOW/VENTILATION:				
BUILDING NAME	NAME	LENGTH	HEIGHT	NOS
A (BUILDING)	V	0.60	0.90	08
A (BUILDING)	W1	0.90	1.20	08
A (BUILDING)	FW	1.00	2.15	04
A (BUILDING)	W	1.20	1.20	16

Building :A (BUILDING)					
Floor Name	Total Built Up Area (Sq.mt.)	Proposed FAR Area (Sq.mt.) Resi.	Total FAR Area (Sq.mt.)	Total Consumed Additional FAR Area (Sq.mt.)	Tnmt (No.)
Ground Floor	131.28	131.28	131.28	131.28	01
First Floor	131.28	131.28	131.28	131.28	00
Terrace Floor	0.00	0.00	0.00	0.00	00
Total :	262.56	262.56	262.56	262.56	01
Total Number of Same Buildings	1				
Total :	262.56	262.56	262.56	262.56	01

Buildingwise Floor FAR Details				
Floor Name	Building Name A (BUILDING)		Total	
	Proposed Built Up Area (Sq.mt.)	Proposed FAR Area (Sq.mt.)	Total Proposed Built Up Area (Sq.mt.)	Total FAR Area (Sq.mt.)
Ground Floor	131.28	131.28	131.28	131.28
First Floor	131.28	131.28	131.28	131.28
Terrace Floor	0.00	0.00	0.00	0.00
Total :	262.56	262.56	262.56	262.56

FAR & Tenement Details (Table 4c-1)

Building	No. of Same Bldg	Total Built Up Area (Sq.mt.)	Proposed FAR Area (Sq.mt.) Resi.	Total FAR Area (Sq.mt.)	Total Consumed Additional FAR Area (Sq.mt.)	Tnmt (No.)
A (BUILDING)	1	262.56	262.56	262.56	262.56	01
Grand Total :	1	262.56	262.56	262.56	262.56	01

UnitBUA Table for Building :A (BUILDING)

FLOOR	Name	UnitBUA Type	UnitBUA Area	Carpert Area	No. of Rooms	No. of Tenement
GROUND FLOOR PLAN	SPLIT S	FLAT	241.59	225.25	15	1
FIRST FLOOR PLAN	SPLIT S	FLAT	0.00	0.00	15	0
Total:	-	-	241.59	225.25	30	1

COLOR INDEX

PLOT BOUNDARY	Black
ABUTTING ROAD	Red
PROPOSED CONSTRUCTION	Green
COMMON PLOT	Blue
ROAD WIDENING AREA	Yellow
EXISTING (To be retained)	Orange
EXISTING (To be demolished)	Purple

LTP NAME AND SIGNATURE	STRUCTURAL ENG'S NAME AND SIGNATURE	BUILDER NAME AND SIGNATURE	DIGITAL SIGNATURE
Mukesh Kumar CMC/ENG/0004/2017			

Building USE/SUBUSE Details

Building Name	Building Use	Building SubUse	Building Structure
A (BUILDING)	Residential	Bungalow/ Dwelling / Non Apartment	Non-Highrise