

Proposal Basic Information	
Proposal File No.	CMC/BP/0218/W13/2021
Owner Name	SHARMANAND KUMAR
Khata No	198
Plot No	6835
Village Name	Chas
Use	Residential
SubUse	Bungalow/ Dwelling / Non Apartment

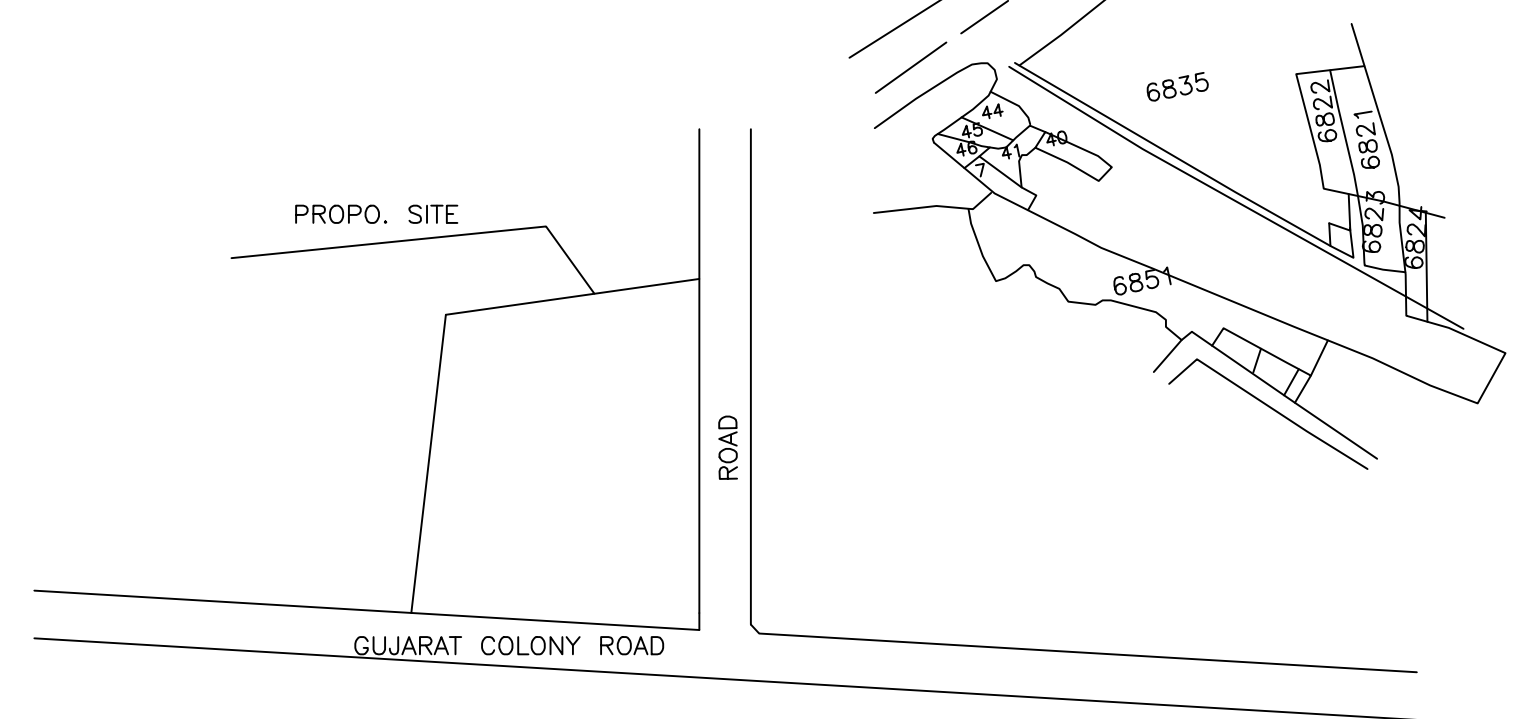

AREA STATEMENT CHAS MUNICIPAL CORPORATION		VERSION NO. : 1.0.60
PROJECT DETAIL:		VERSION DATE: 16/10/2020
Region: JHARKHAND URBAN LOCAL BODIES	Plot Use: Residential	
District: BOKARO	Plot SubUse: Bungalow/ Dwelling / Non Apartment	
Authority: CHAS MUNICIPAL CORPORATION	PlotNearbyReligiousStructure: NA	
Inward No: CMC/BP/0218/W13/2021	PlotSubPlot No: 6835	
Application Type: General Proposal	North: CTS No. - BUILDING OF SINGH JI	
Project Type: Building Permission	South: Road Width - 4.57 mtr wide road	
Nature of Development: New	East: CTS No. - 3.66mtr wide road	
Location of Development Area: Old Area	West: CTS No. - HARDEO PRASAD	
AREA DETAILS:		SQ. MT.
AREA OF PLOT (Minimum)	(A)	209.99
NET AREA OF PLOT(Gross Plot Area - Deduction from Gross Plot area)	(A-Deductions)	209.99
Deduction for Balance Plot Area(from Gross Plot Area)		
Common Plot		14.46
Total		14.46
BALANCE AREA OF PLOT(Net Plot Area - Recreational/Amenity space)	(A-Deductions)	195.52
PLOT AREA FOR COVERAGE(Net Plot Area)	(A-Deductions)	209.99
Plot Area for FAR (Net Plot Area + Road Widening Area)	(A-Deductions)	209.99
COVERAGE CHECK		
Permissible Coverage area (70.00 %)		146.99
Proposed Coverage Area (61.78 %)		129.73
Total Prop. Coverage Area (61.78 %)		129.73
Balance coverage area (8.22 %)		17.26
FAR CHECK		
Perm. FAR Area (1.50)		314.99
Total Perm. FAR area		314.99
Residential FAR		259.46
Proposed FAR Area		259.46
Total Proposed FAR Area		259.46
Consumed FAR (Factor)		1.24
Balance FAR Area		55.53
BUILT UP AREA CHECK		
Total Proposed BuiltUp Area		259.46
ARCHITECT (Regd)	AMRIT KUMAR MAHATO	
ENGINEER (Regd)		
SUPERVISOR (Regd)	SHARMANAND KUMAR	
OWNER (Regd)		
DEVELOPMENT AUTHORITY	LOCAL BODY	

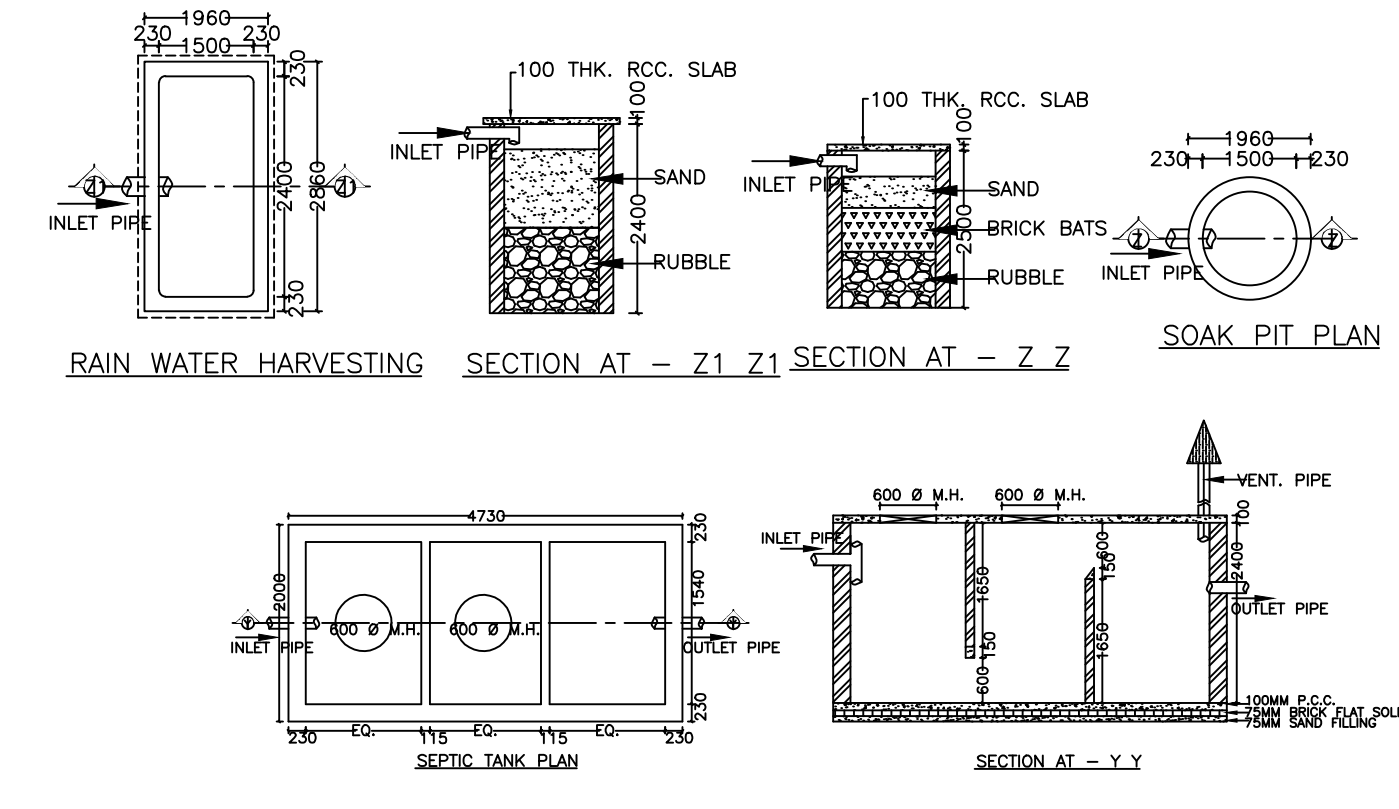
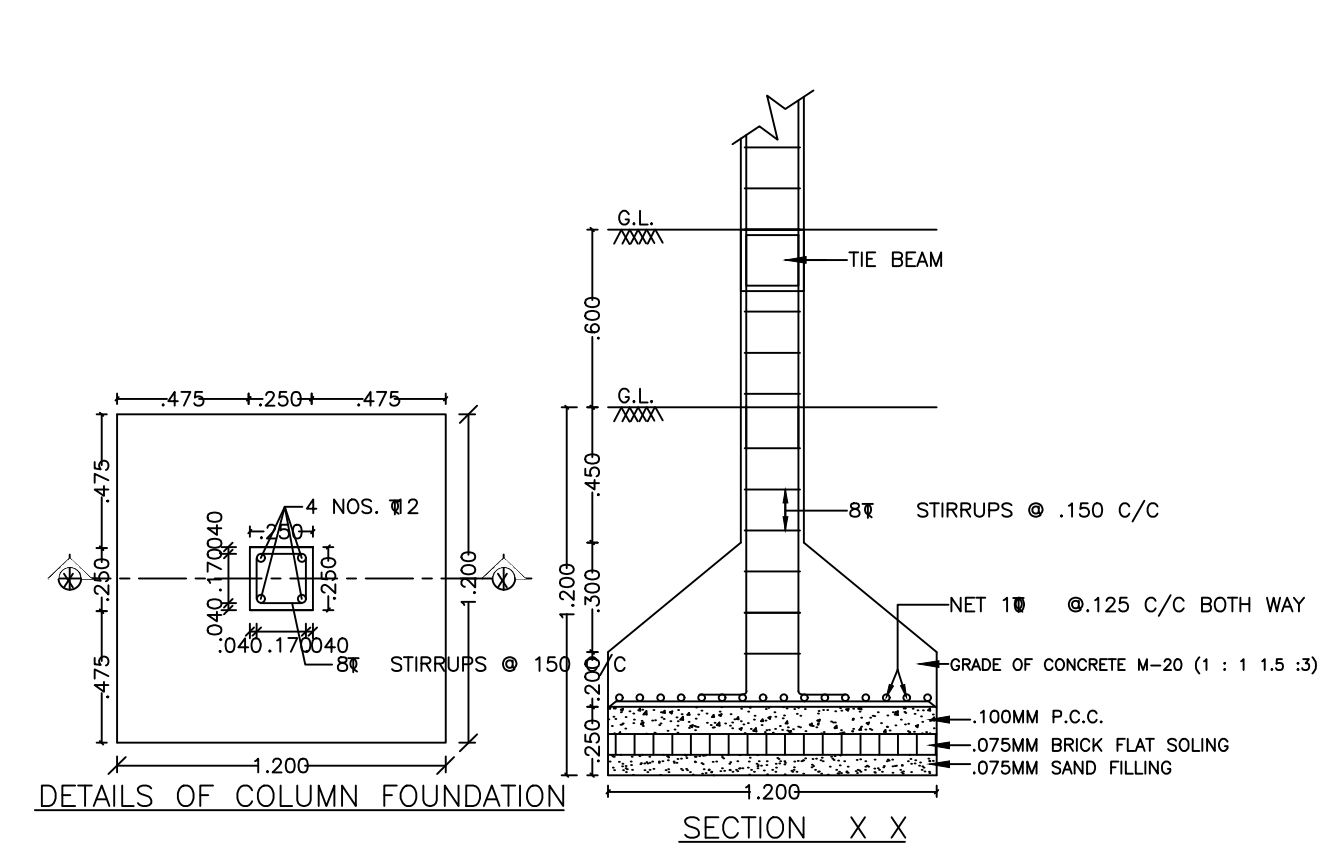
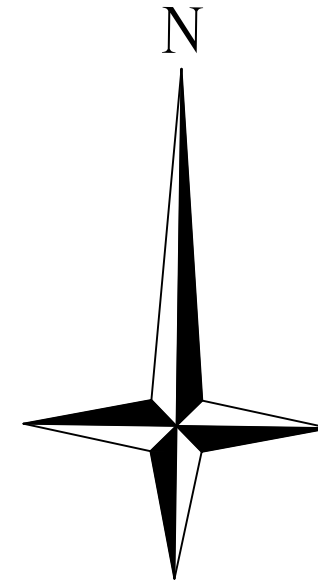
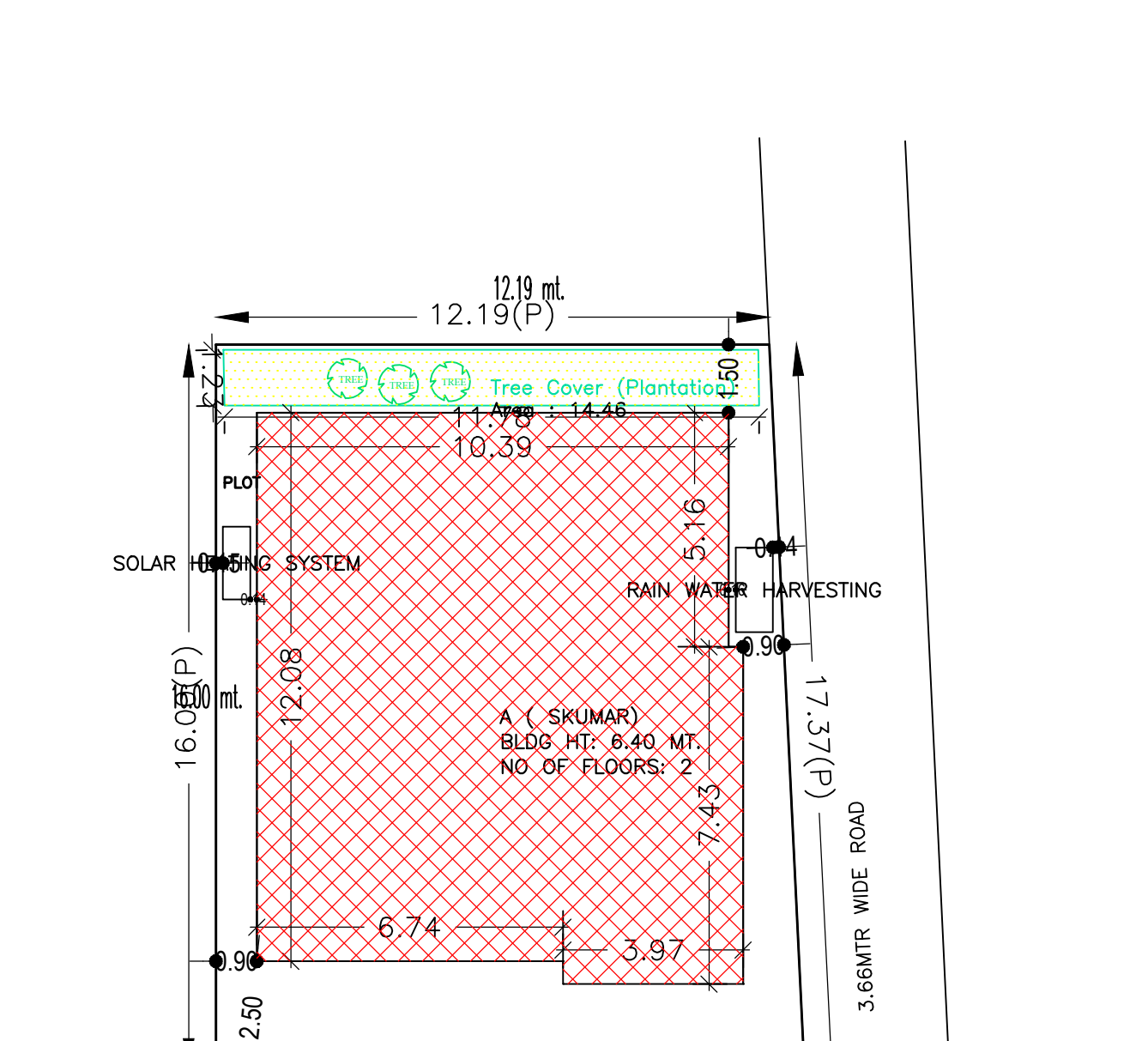
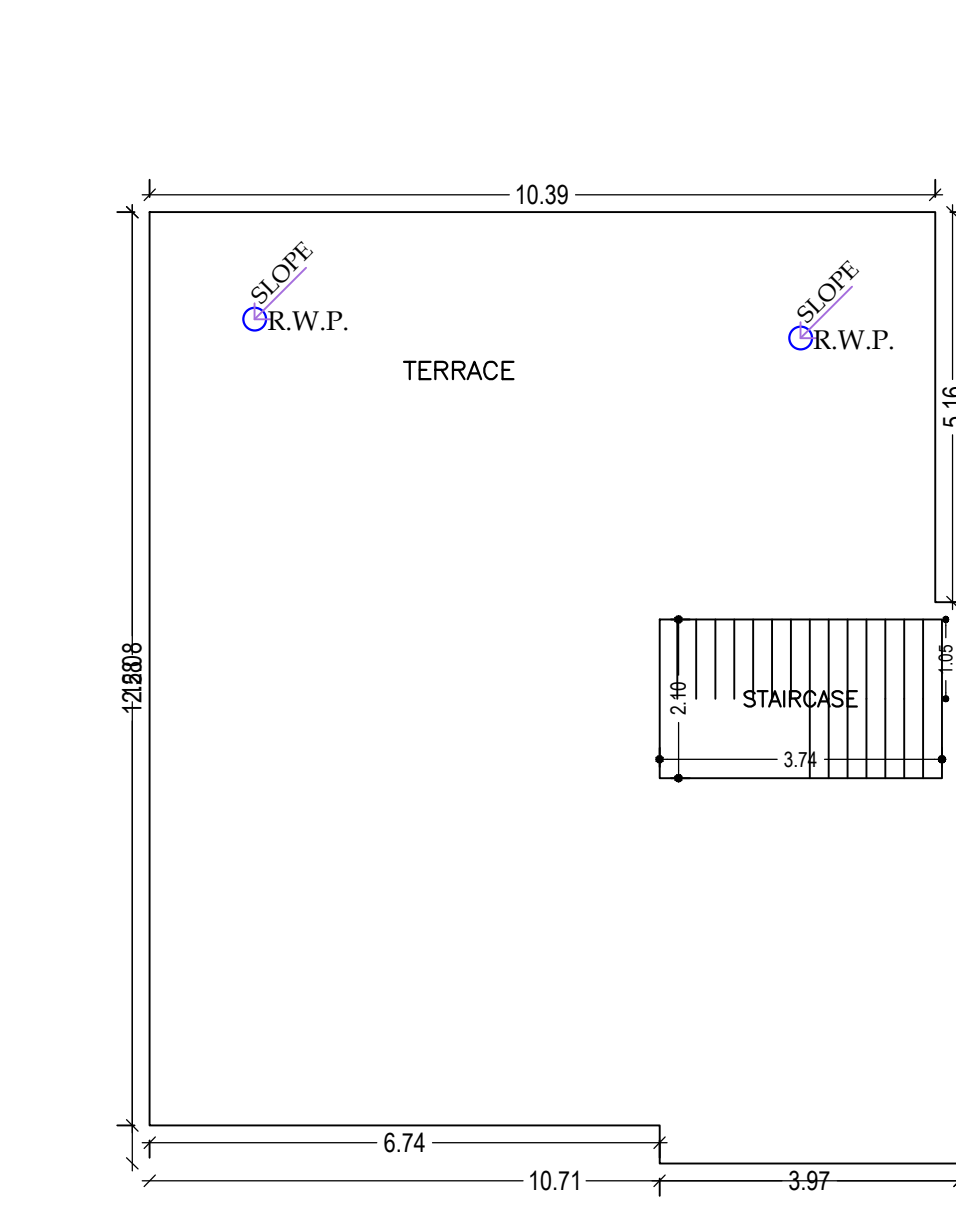
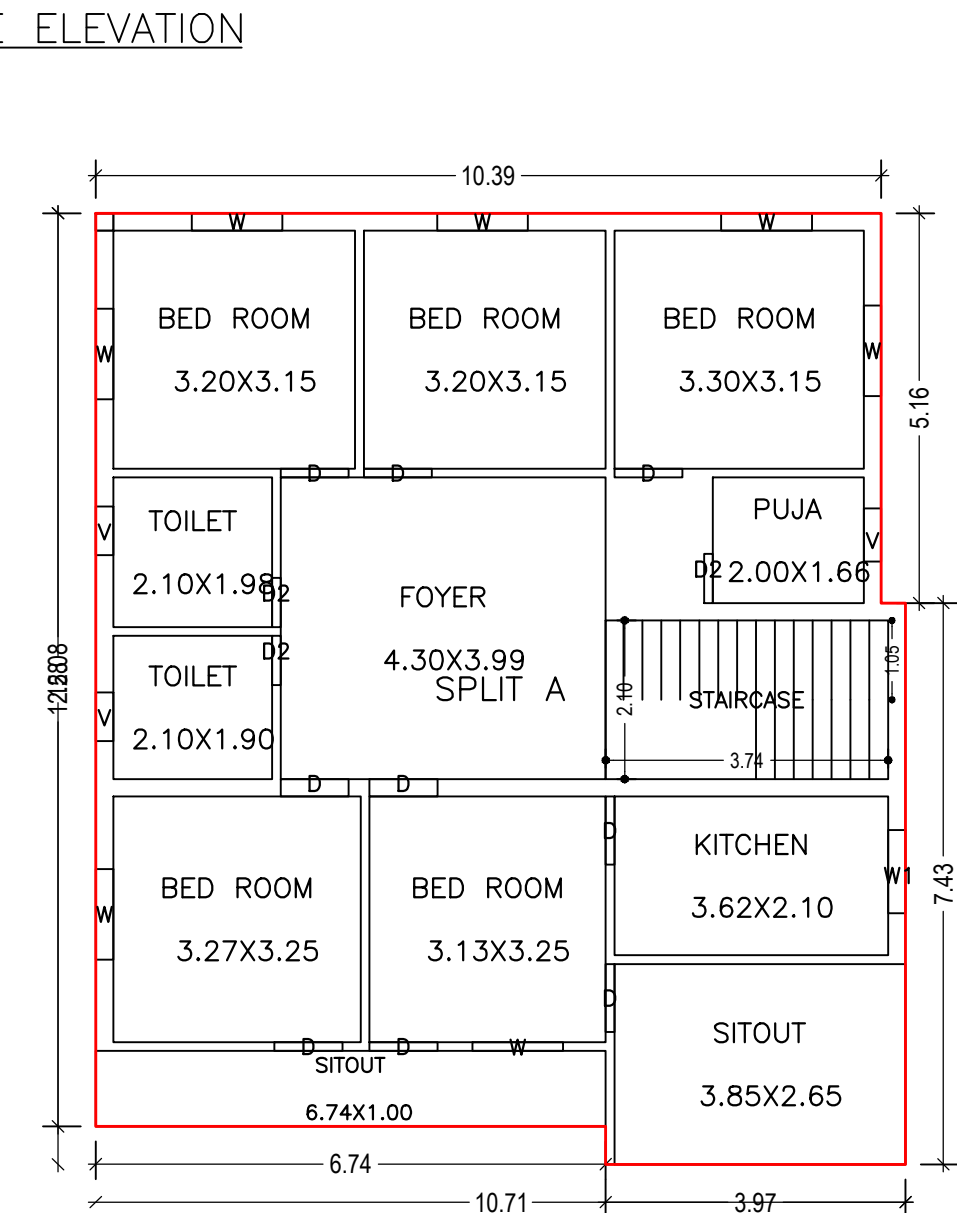
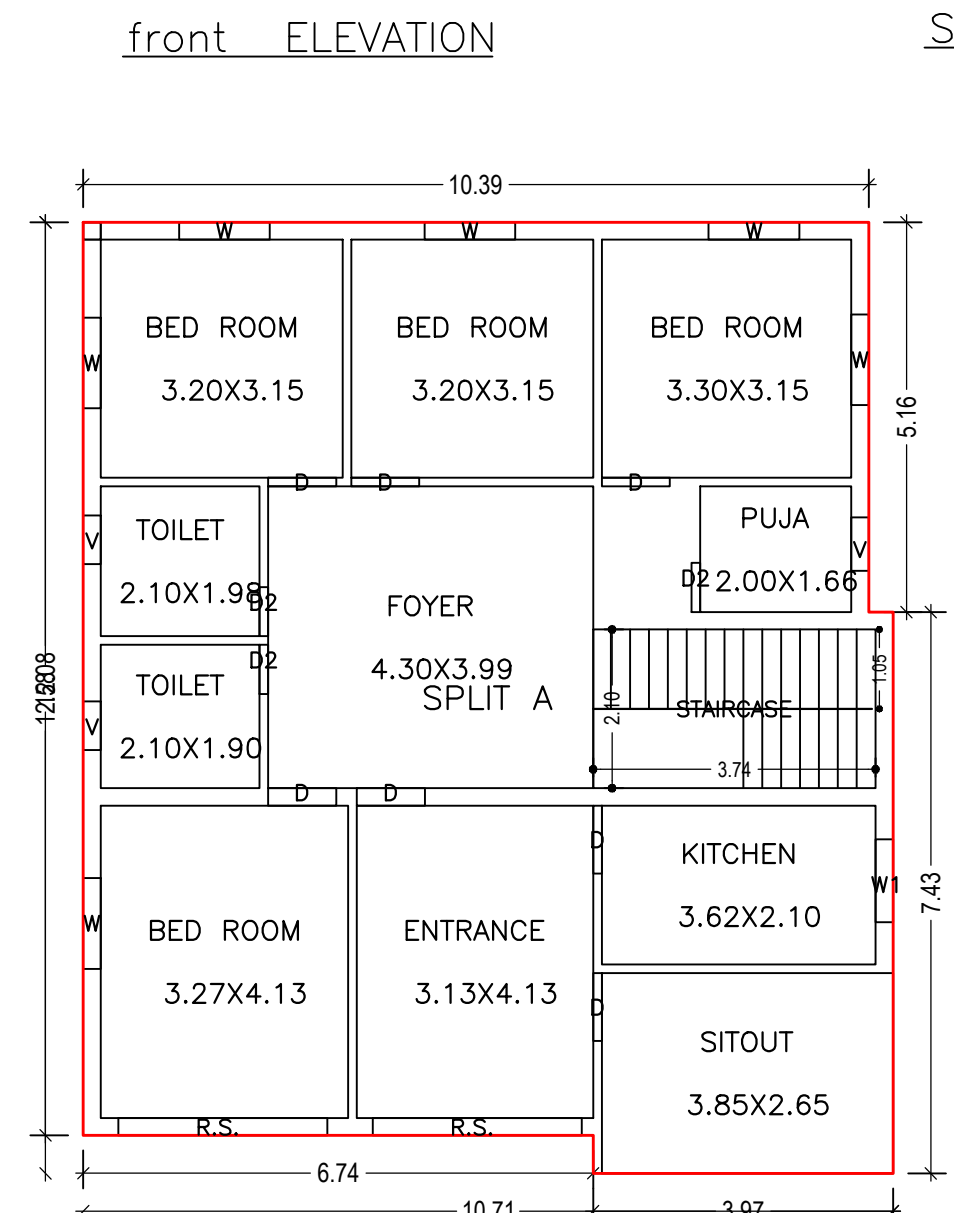
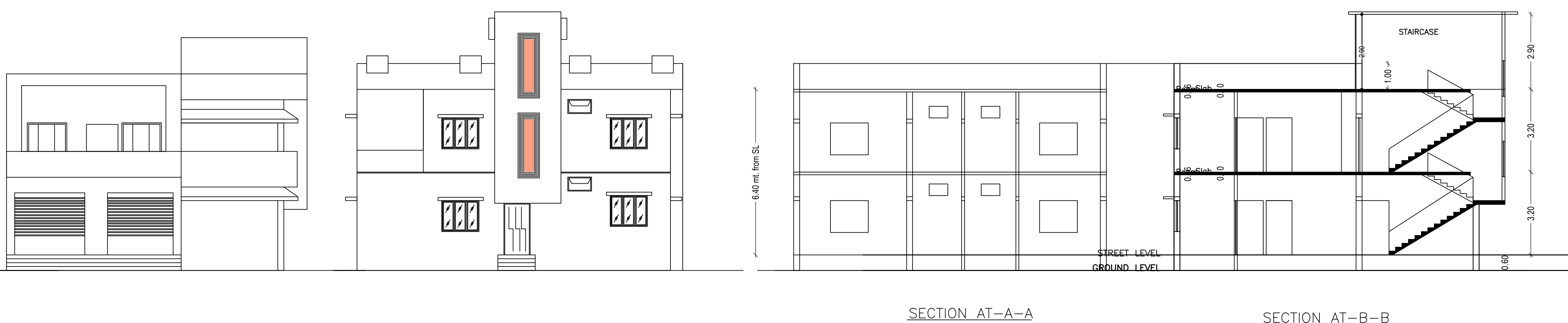

BUILDING NAME	NAME	LENGTH	HEIGHT	NOS
A (SKUMAR)	D2	0.65	2.10	06
A (SKUMAR)	D	0.90	2.10	16
A (SKUMAR)	R.S.	2.76	2.10	02

BUILDING NAME	NAME	LENGTH	HEIGHT	NOS
A (SKUMAR)	V	0.64	1.20	04
A (SKUMAR)	V	0.70	1.20	02
A (SKUMAR)	W1	1.10	1.20	02
A (SKUMAR)	W	1.20	1.20	13

Floor Name	Total Built Up Area (Sq.mt.)	Proposed FAR Area (Sq.mt.)	Total FAR Area (Sq.mt.)	Total Consumed Additional FAR Area (Sq.mt.)	Trmt (No.)
Ground Floor	129.73	129.73	129.73	129.73	01
First Floor	129.73	129.73	129.73	129.73	00
Terrace Floor	0.00	0.00	0.00	0.00	00
Total:	259.46	259.46	259.46	259.46	01
Total Number of Same Buildings :	1				
Total :	259.46	259.46	259.46	259.46	01

Floor Name	Building Name A (SKUMAR)		Total	
	Proposed Built Up Area (Sq.mt.)	Proposed FAR Area (Sq.mt.)	Total Proposed Built Up Area (Sq.mt.)	Total FAR Area (Sq.mt.)
Ground Floor	129.73	129.73	129.73	129.73
First Floor	129.73	129.73	129.73	129.73
Terrace Floor	0.00	0.00	0.00	0.00
Total :	259.46	259.46	259.46	259.46

FLOOR	Name	UnitBUA Type	UnitBUA Area	Carpet Area	No. of Rooms	No. of Tenement
GROUND FLOOR PLAN	SPLIT A	FLAT	259.46	259.35	11	1
FIRST FLOOR PLAN	SPLIT A	FLAT	0.00	0.00	12	0
Total:	-	-	259.46	259.35	23	1

Building	No. of Same Bldg	Total Built Up Area (Sq.mt.)	Proposed FAR Area (Sq.mt.)	Total FAR Area (Sq.mt.)	Total Consumed Additional FAR Area (Sq.mt.)	Trmt (No.)
A (SKUMAR)	1	259.46	259.46	259.46	259.46	01
Grand Total :	1	259.46	259.46	259.46	259.46	01

Building Name	Building Use	Building SubUse	Building Structure
A (SKUMAR)	Residential	Bungalow/ Dwelling / Non Apartment	Non-Highrise

PLOT BOUNDARY	Black
ABUTTING ROAD	Green
PROPOSED CONSTRUCTION	Red
COMMON PLOT	Yellow
ROAD WIDENING AREA	Blue
EXISTING (To be retained)	Orange
EXISTING (To be demolished)	Light Blue

LTP NAME AND SIGNATURE	STRUCTURAL ENG'S NAME AND SIGNATURE	BUILDER NAME AND SIGNATURE	DIGITAL SIGNATURE
AMRIT KUMAR MAHATO CMC/DFTM/0004/2019			