

Project Title : REKHA DEVI

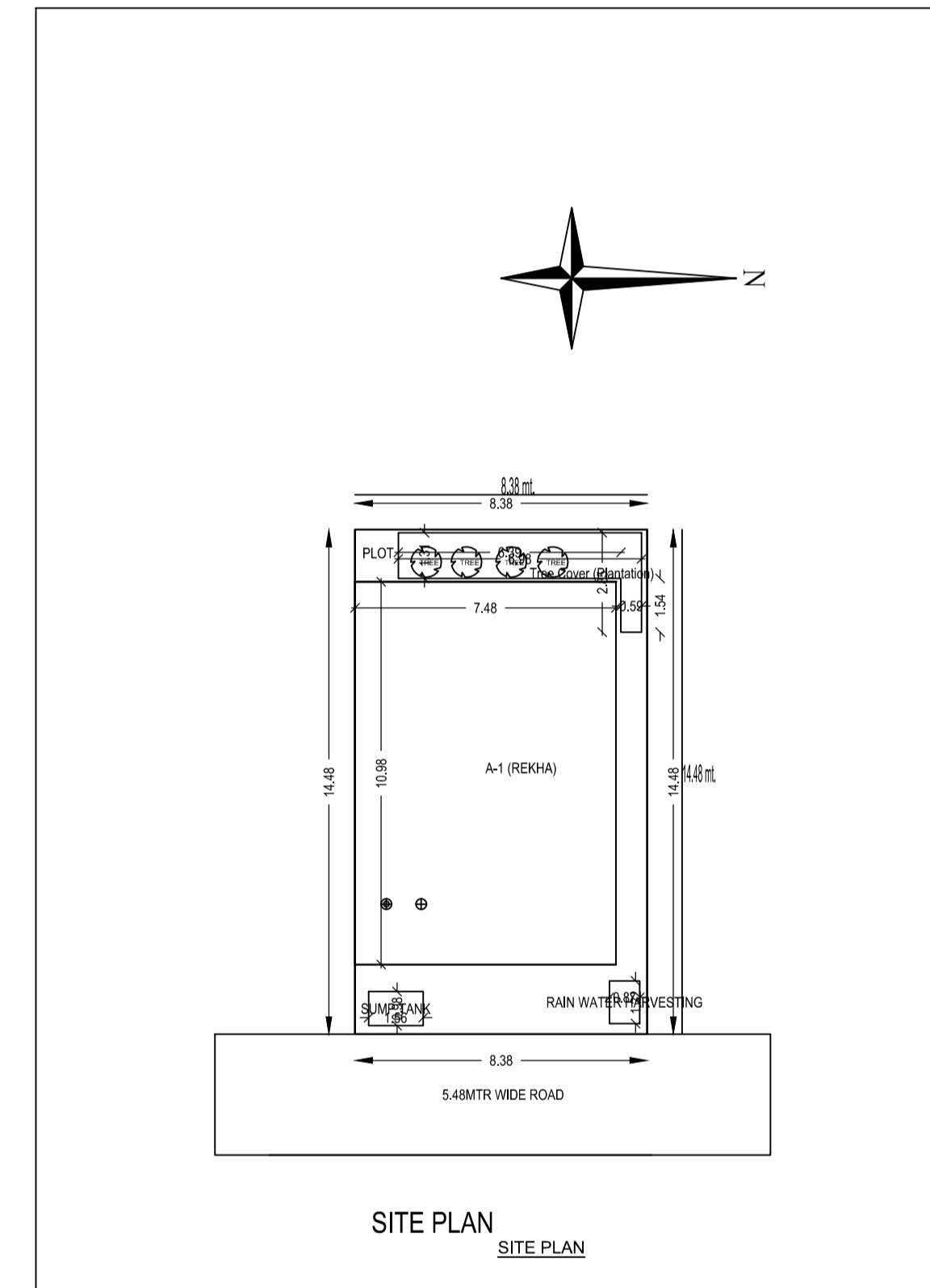
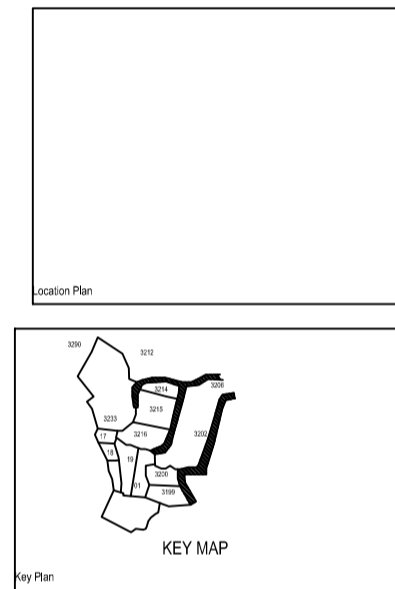
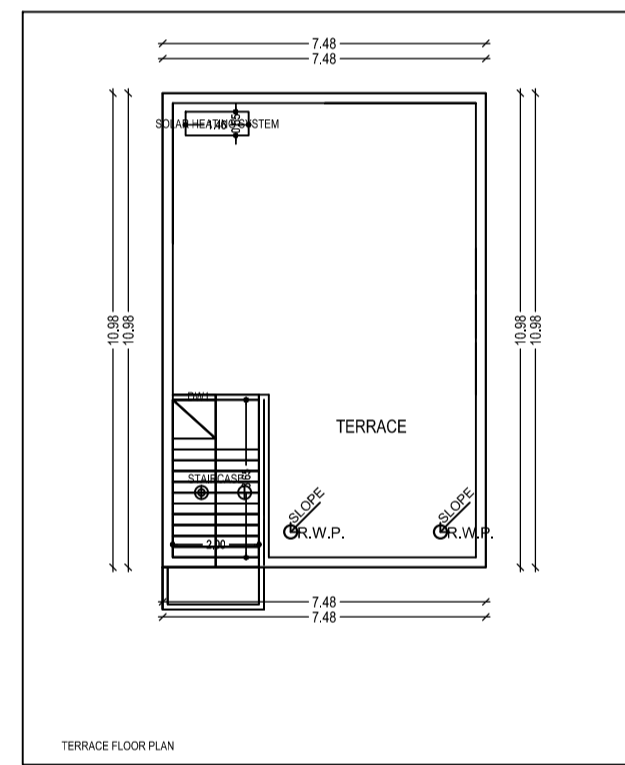
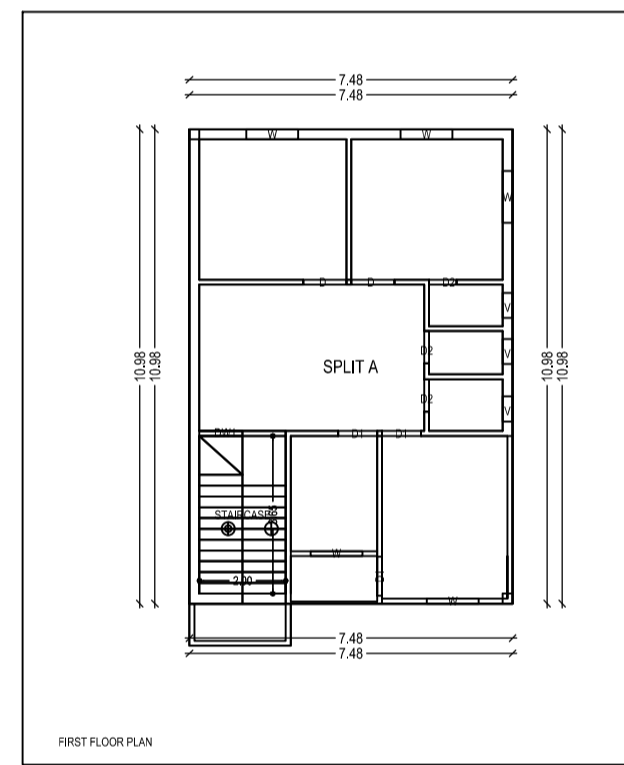
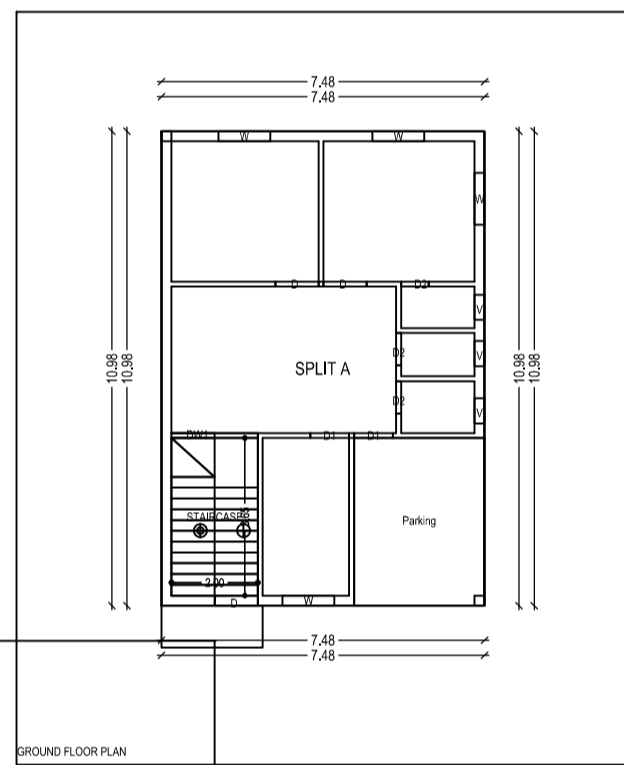
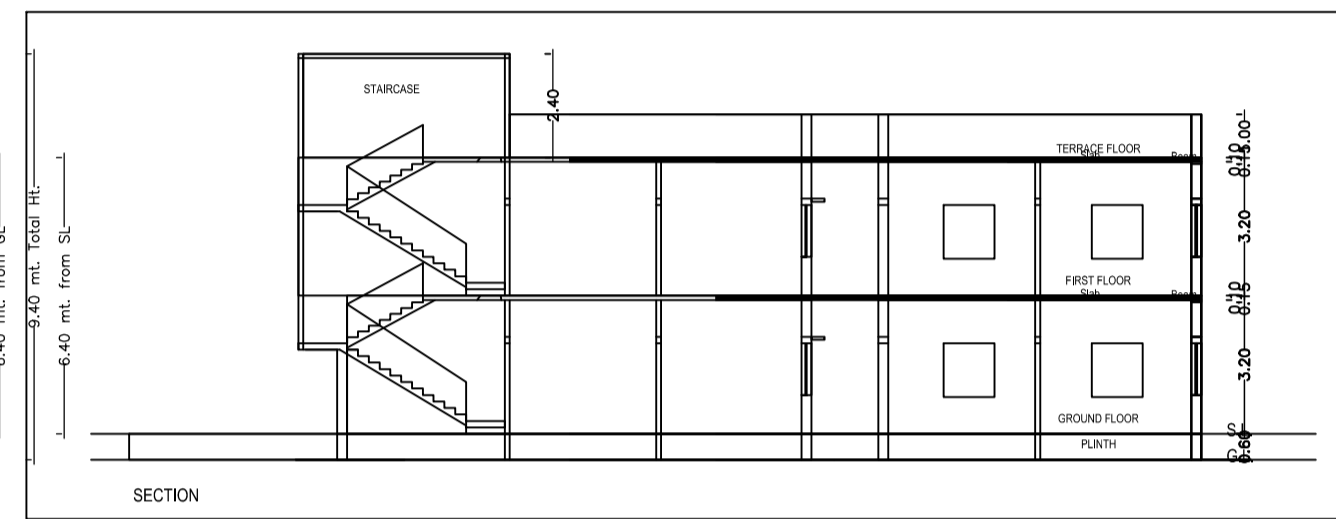
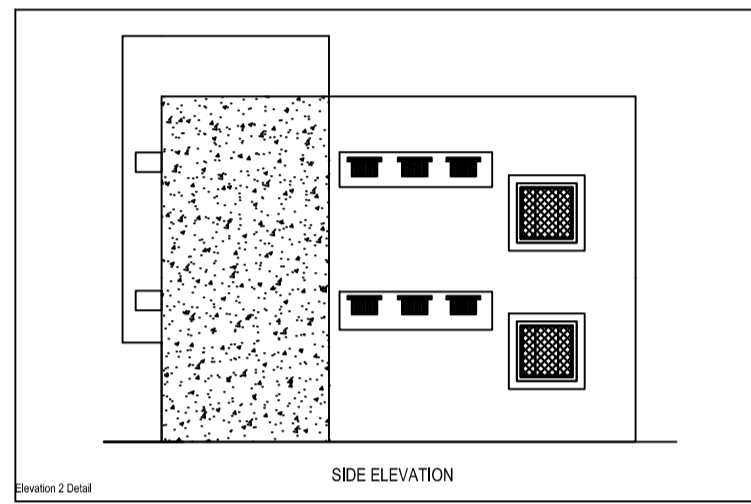
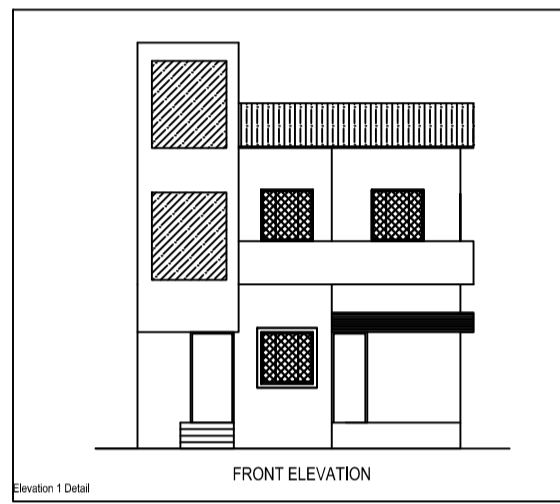
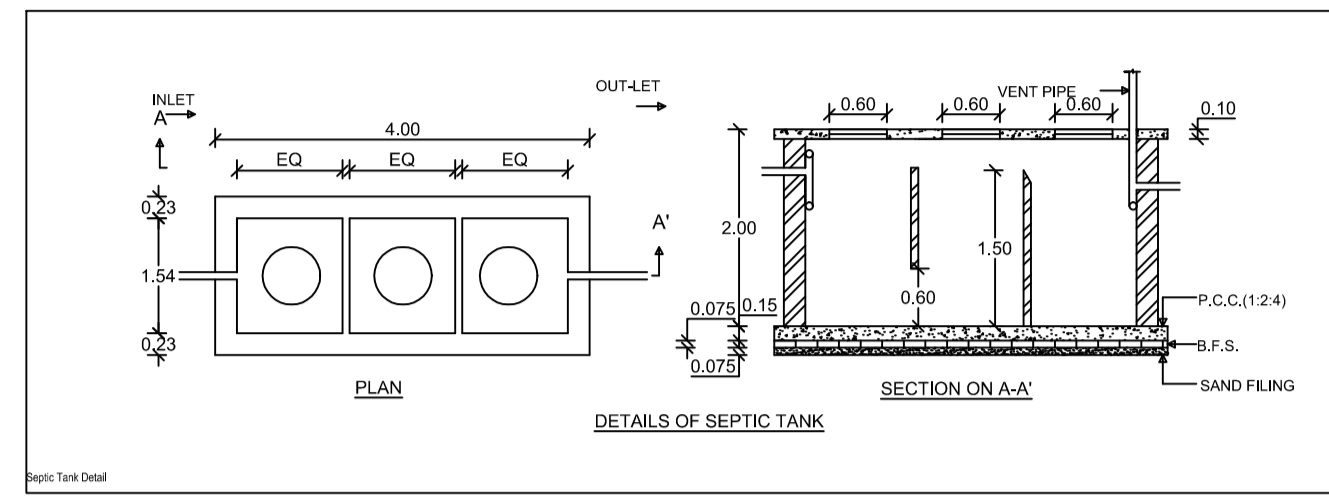
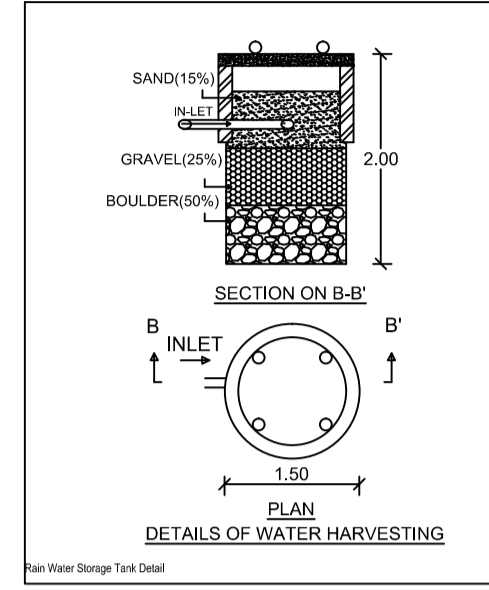
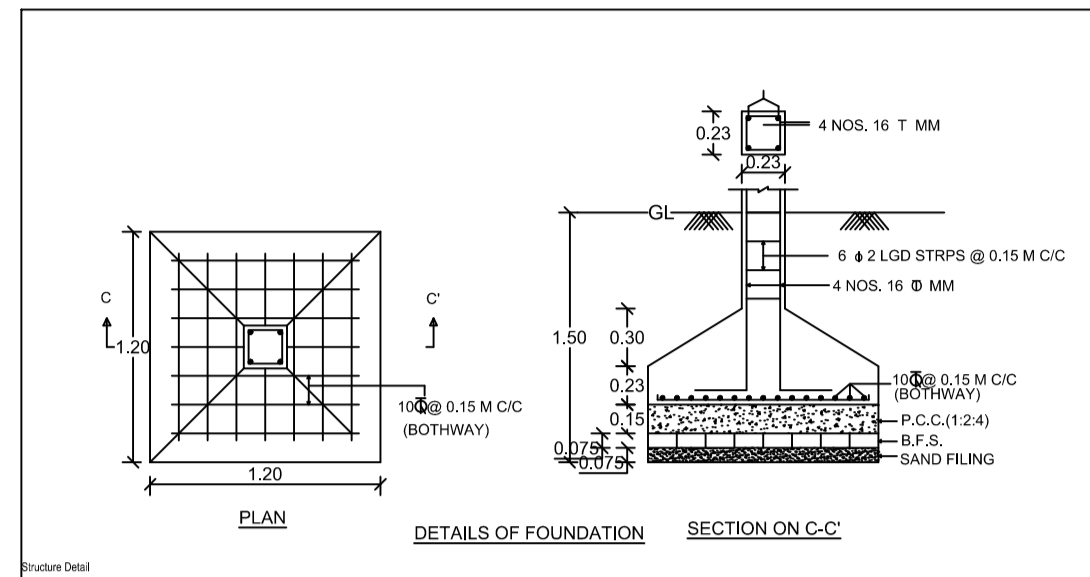

AREA DEVELOPMENT/URBAN MUNICIPAL CORPORATION		VERSION NO. 1.1.20
PROJECT DETAIL		VERSION DATE: 16/10/2020
Project No. :	PAJ Use - Residential	
Region :	CHANNarayana LOCAL BODIES	PAJ Building - Bungalow/Dwelling/ Non Apartment
Project Category :	Local Use Zone - RA	
Application Type :	General Proposal	Activity Road Width -
Project Type :	Building Permission	PAJ No. -
Location :	Off Area	Permitted Survey No/Survey No. -
Site Location :	RA	PAJ No. -
Village/Moza Name :		Area No. -
Ward No. :		Plot No. -
Road Name :		Plot No. -
Plot No. :		Plot No. -
Plot Area (sq.m)	82.13	
Net Plot Area (Gross Plot Area - (A) Deductions)	121.34	
- Deductions from Gross Plot Area		
- Deductions for Balance Plot Area (from Gross Plot Area)	13.04	
- COP Area	13.28	
Final	111.28	
Balance Plot Area (Net Plot Area - Functional Area) (sq.m)	111.28	
Plot Area of Coverage (Net Plot Area)	121.34	
Plot Area of 75% Net Plot Area + (A) Deductions	121.34	
COVERAGE CHECK		
- Proposed Coverage Area (FAR %)	82.13	
- FAR Coverage Area (FAR %)	82.13	
FAR CHECK		
Proposed Area of FAR	164.26	
Plot Area of FAR	164.26	
REALITY CHECK		
Plot Proposed Building Area	164.26	
Plot Proposed Building Area	164.26	
OWNER		
DEVELOPMENT AUTHORITY		LOCAL BODY

COLOR INDEX	
PLOT BOUNDARY	---
ADJUTING ROAD	---
PROPOSED ROOF COVERAGE AREA	---
EXISTING (To be retained)	---
EXISTING (To be demolished)	---

PARKING CALCULATION:		
Parking Type	Prop No.	Prop Area
Other Parking	1	11.72
Total Area	-	11.72

MARGIN DETAIL:					
Building Wing	Road Name	Front Margin	Rear Margin	Side Margin	Side Margin
A (REKHA)	5.48MTR WIDE ROAD	2.00	1.50	0.00	0.00

FAR & Termination Details (Table 4c-1)					
Building	No. of Same Bldg	Total Built Up Area (Sq.ft.)	Proposed FAR Area (Sq.ft.)	Total FAR Area (Sq.ft.)	Termination
A (REKHA)	1	164.26	164.26	164.26	01
Grand Total	1	164.26	164.26	164.26	01

Building A (REKHA)				
Floor Name	Total Built Up Area (Sq.ft.)	Proposed FAR Area (Sq.ft.)	Total FAR Area (Sq.ft.)	Termination (No.)
Ground Floor	82.13	82.13	82.13	01
First Floor	82.13	82.13	82.13	01
Roof Floor	0.00	0.00	0.00	00
Total	164.26	164.26	164.26	01
Total Number of Same Buildings	1			
Total	164.26	164.26	164.26	01

SCHEDULE OF JOINERY:				
BUILDING NAME	NAME	LENGTH	HEIGHT	NO. OF
A (REKHA)	DO	0.85	2.10	02
A (REKHA)	DO	0.78	2.10	02
A (REKHA)	DO	0.80	2.10	02
A (REKHA)	DO	1.00	2.10	02
Total	-	-	-	08

SCHEDULE OF JOINERY:				
BUILDING NAME	NAME	LENGTH	HEIGHT	NO. OF
A (REKHA)	W	1.20	1.20	02
A (REKHA)	DO	1.00	1.20	02
Total	-	-	-	04

Unit/BUA Table for Building A (REKHA)						
FLOOR	Name	Unit/BUA Type	Unit/BUA Area	Carpet Area	No. of Rooms	No. of Tenement
GROUND FLOOR PLAN	SPLIT A	FLAT	164.26	164.16	7	1
Total	-	-	164.26	164.16	08	1