

Project Title : BANDANA SINGH

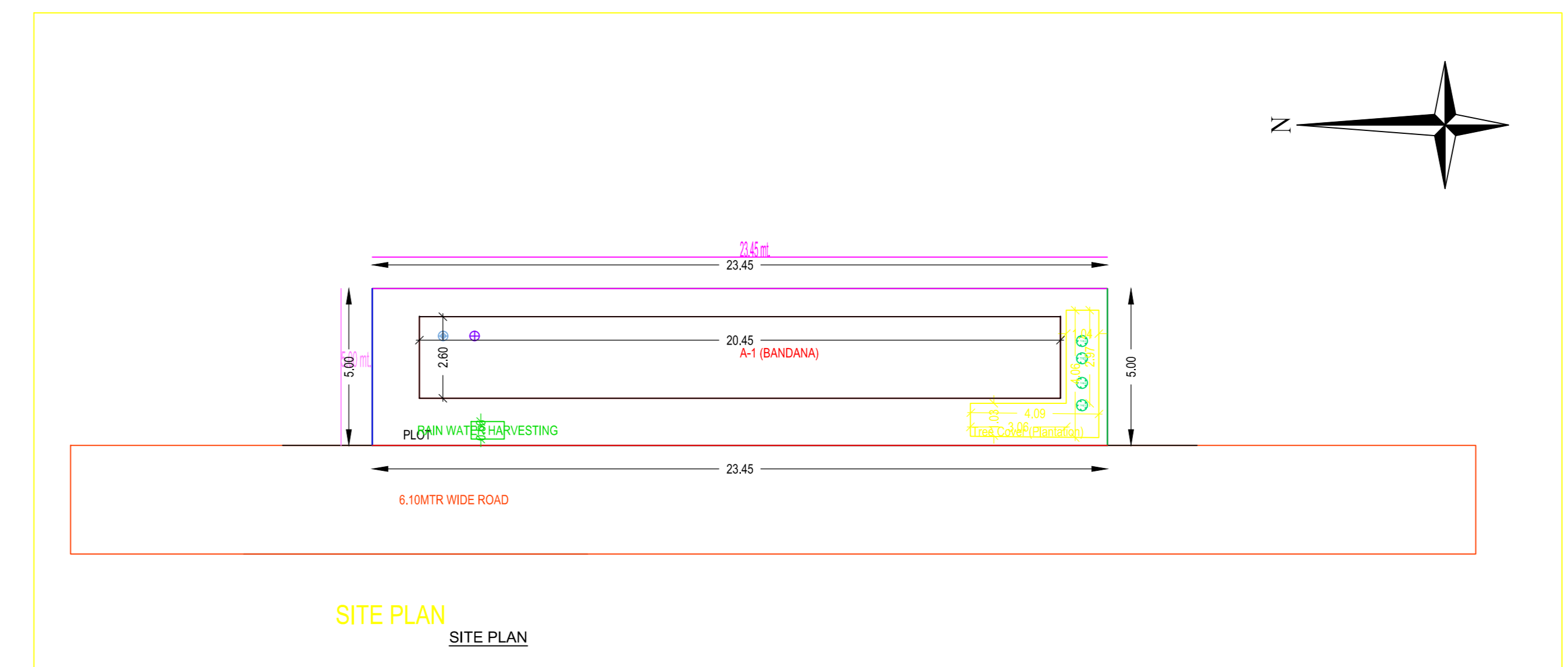
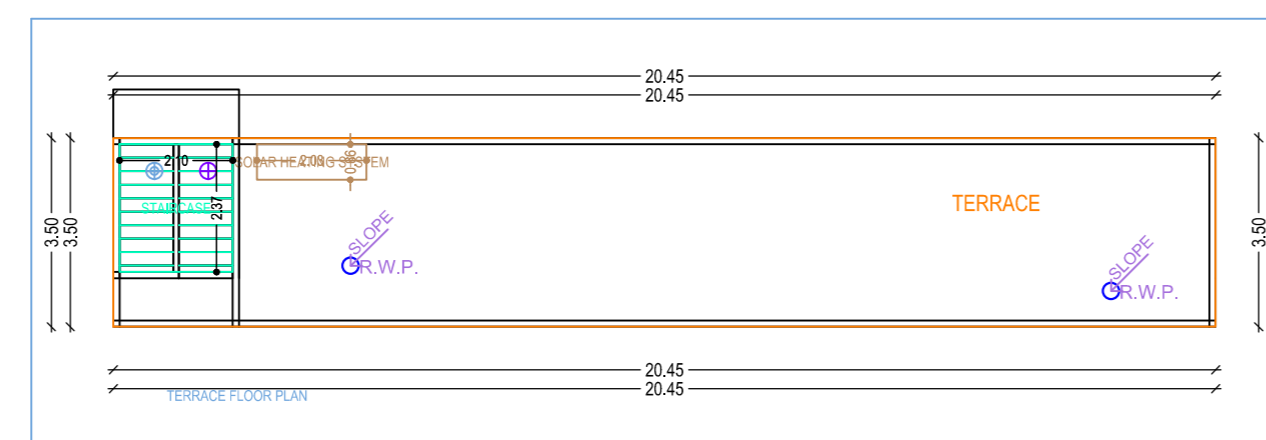
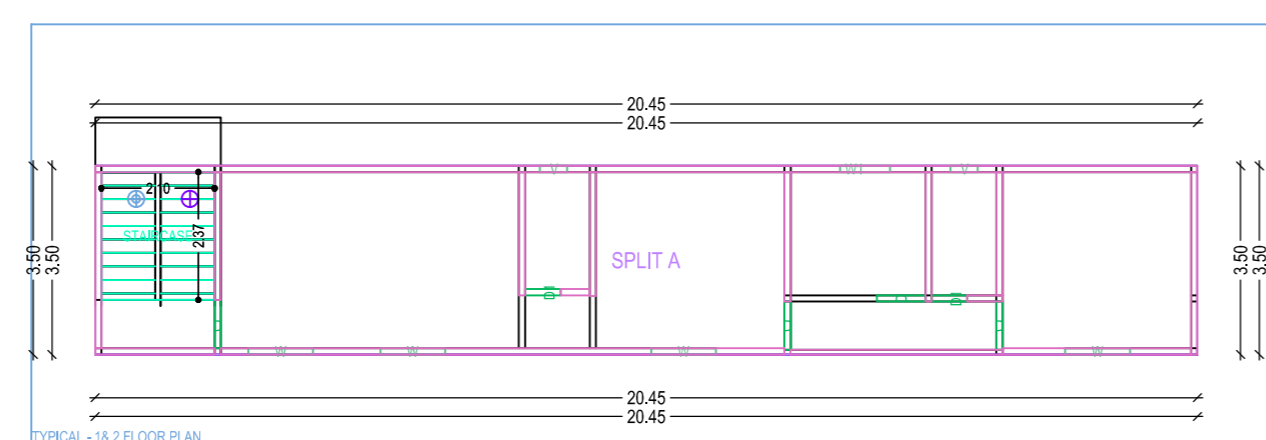
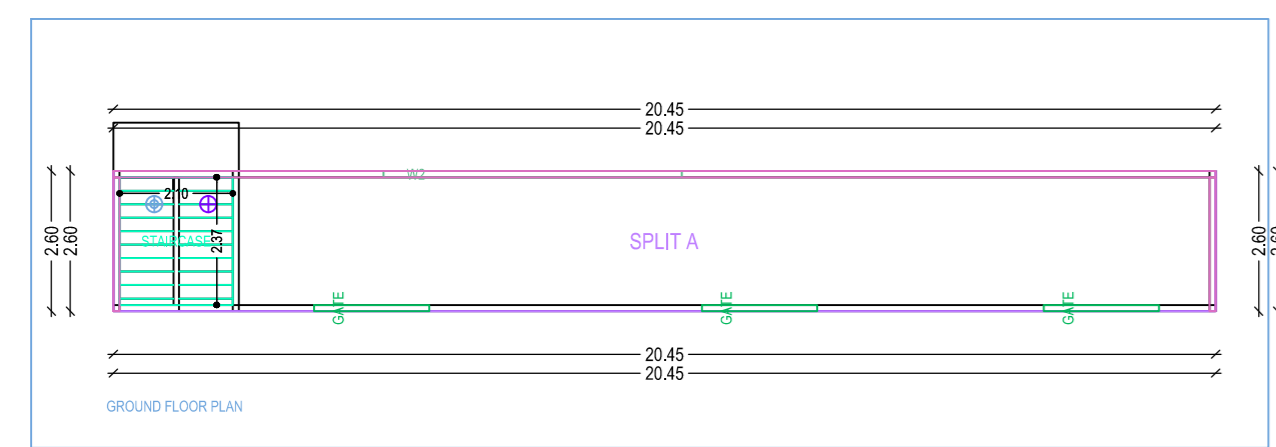
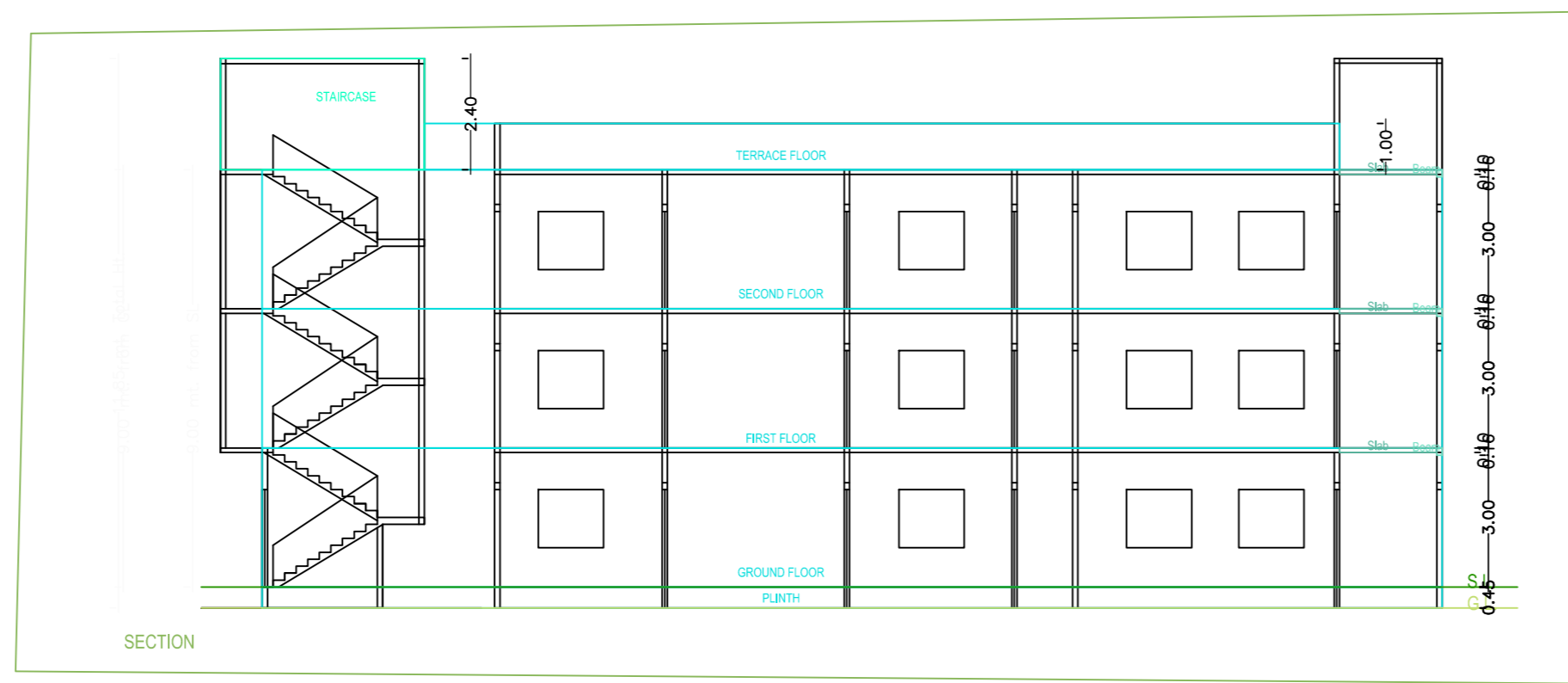
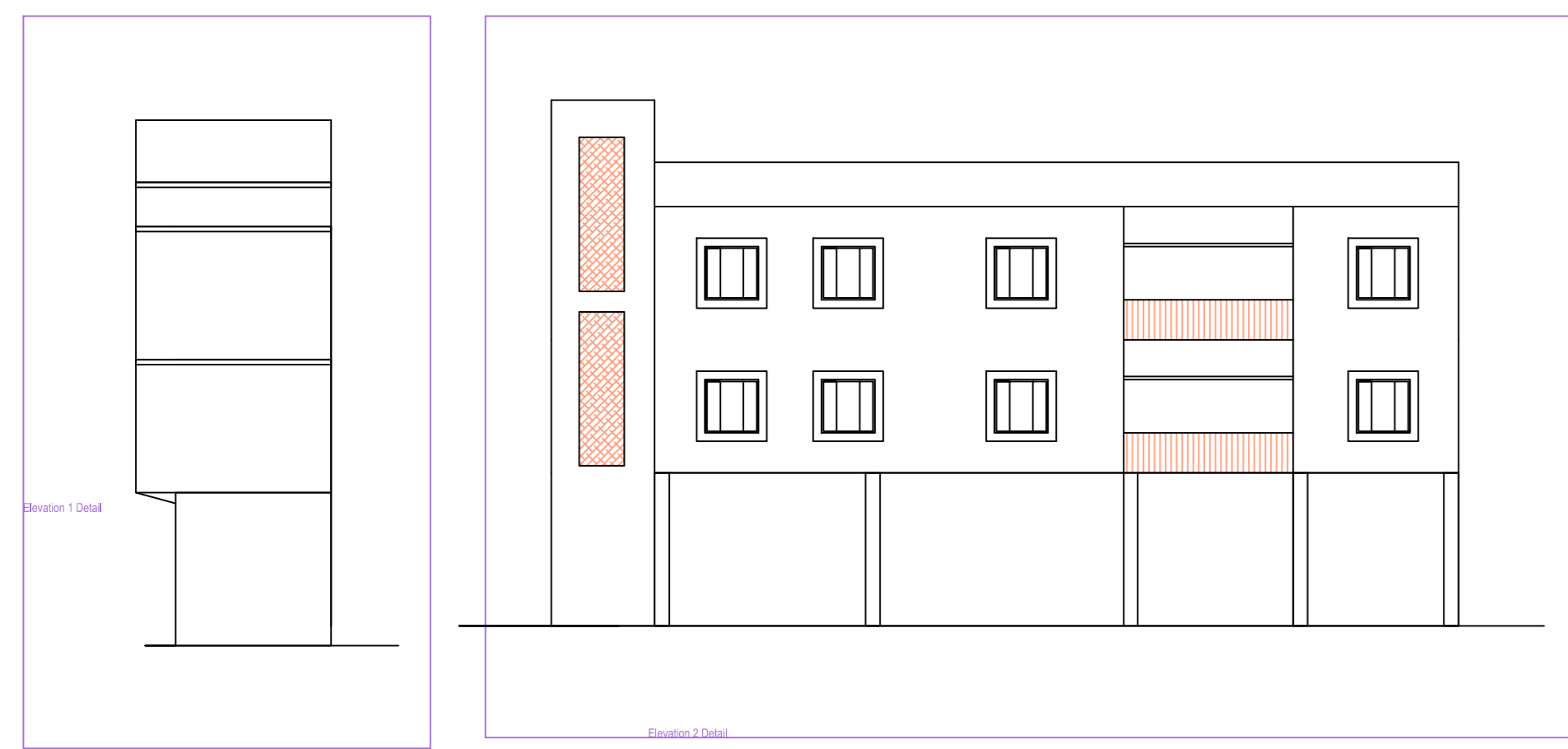
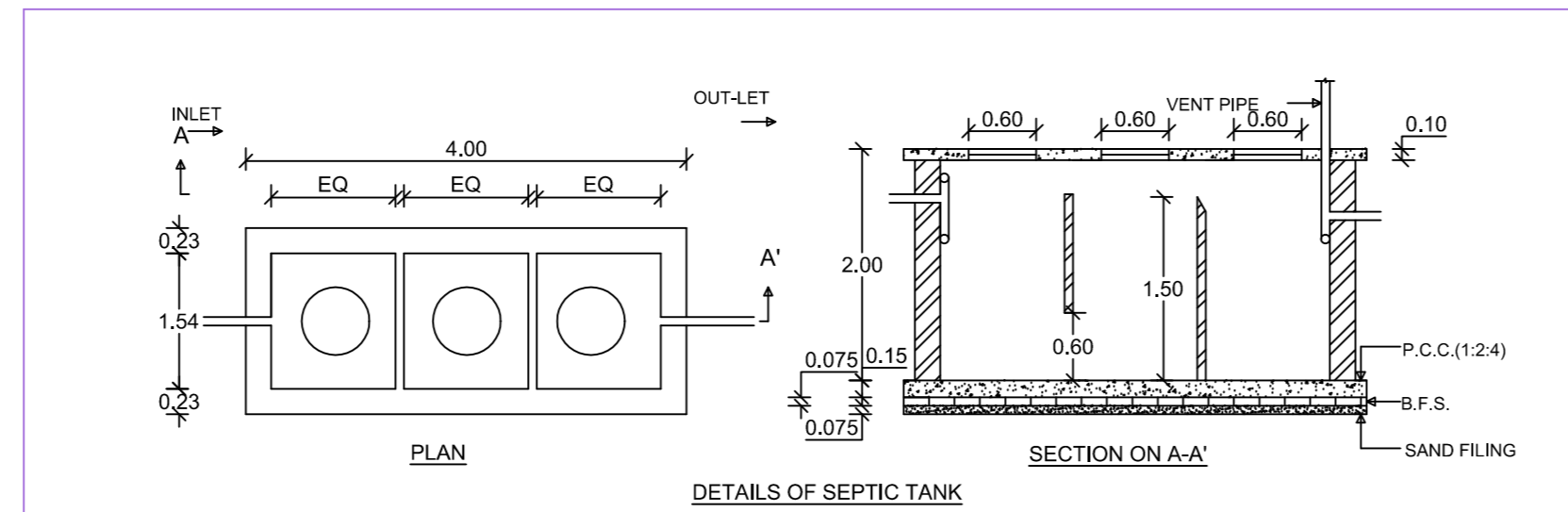
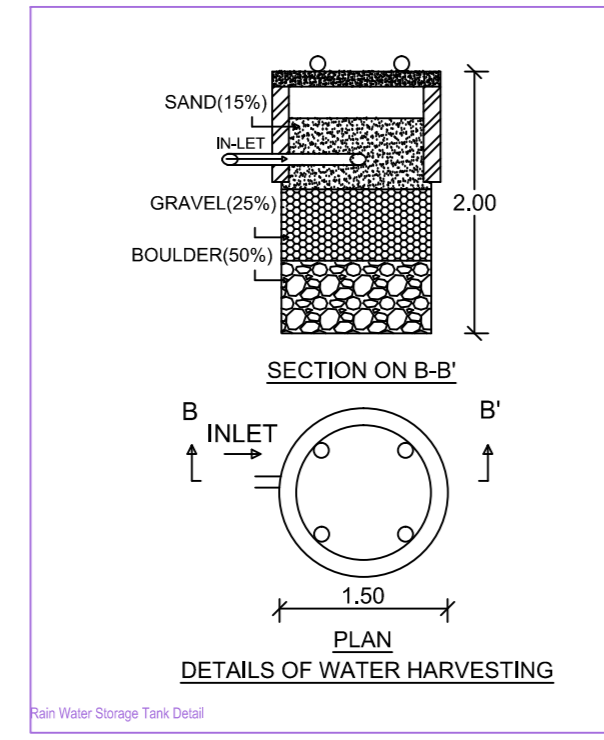
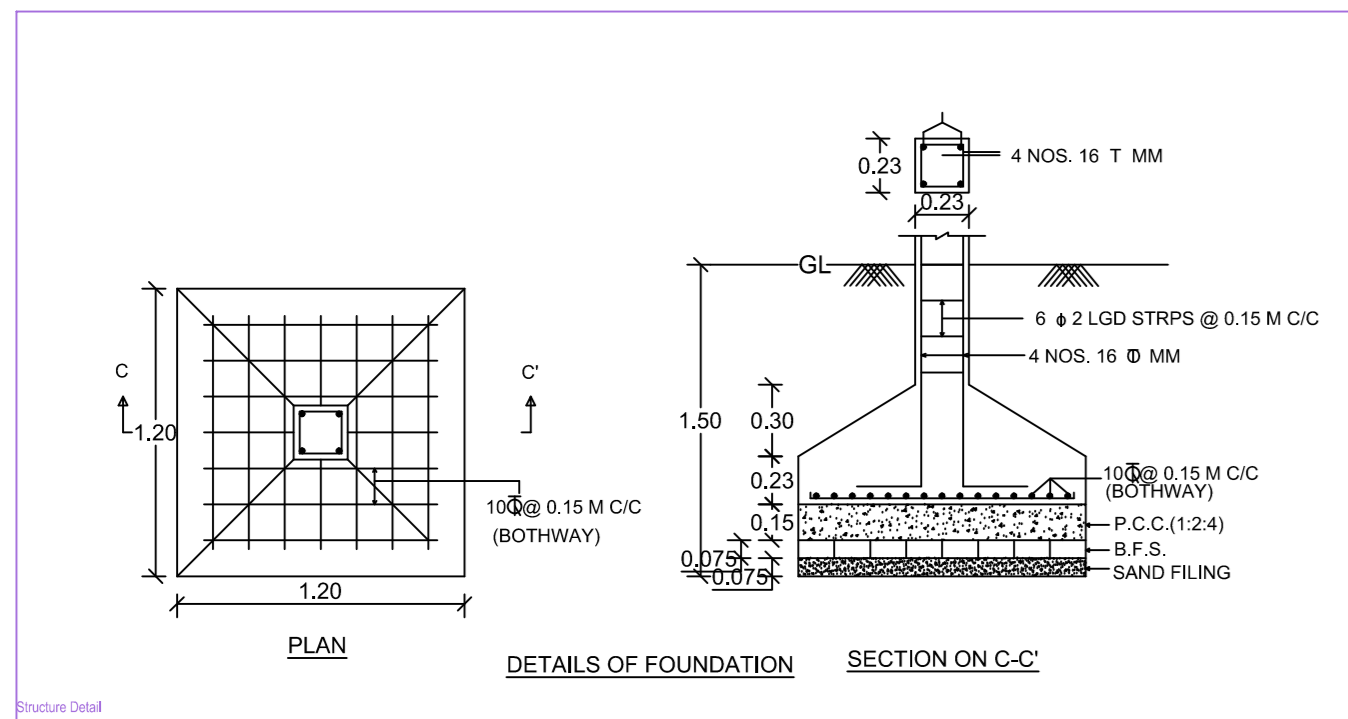

Building A (BANDANA)

Floor Name	Total Built Up Area (Sq.M)	Proposed FSI Area (Sq.M)	Total FSI Area (Sq.M)	Floor Area
Ground Floor	63.31	63.31	63.31	01
1st Floor	11.54	11.54	74.85	01
2nd Floor	11.54	11.54	86.39	01
Terrace	0.00	0.00	86.39	01
Total	86.39	86.39	86.39	04

SCHEDULE OF JOINERY:

ITEM NO.	NAME	LENGTH	HEIGHT	NO.
1	WOODEN DOOR	0.90	2.10	04
2	WOODEN WINDOW	0.90	2.10	08
3	WOODEN WINDOW	1.20	2.10	08
4	WOODEN WINDOW	1.50	2.10	04
5	WOODEN WINDOW	1.80	2.10	02
6	WOODEN WINDOW	2.10	2.10	01
Total				27

SCHEDULE OF JOINERY:

ITEM NO.	NAME	LENGTH	HEIGHT	NO.
1	WOODEN DOOR	0.90	2.10	04
2	WOODEN WINDOW	0.90	2.10	08
3	WOODEN WINDOW	1.20	2.10	08
4	WOODEN WINDOW	1.50	2.10	04
5	WOODEN WINDOW	1.80	2.10	02
6	WOODEN WINDOW	2.10	2.10	01
Total				27

UNIT/SLAB Table for Building A (BANDANA)

FLOOR	Name	UNIT/SLAB Type	Carpet Area	Slab Area	No. of Rooms	No. of Bathrooms
GROUND FLOOR	SPLIT A	FLAT	14.74	14.74	1	1
1ST FLOOR			14.74	14.74	1	1
Total			29.48	29.48	2	2

AREA TREATMENT CHARACTERISTICS

COMPARISON	VERSION NO.	DATE
PROJECT DETAIL	1.01	10/10/2020

PROJECT DETAIL

Project No.	10/10/2020
Project Name	BANDANA SINGH
Project Type	General Proposal
Project Location	Bandana Singh
Project Status	Approved
Project Date	10/10/2020
Project No.	10/10/2020
Project Name	BANDANA SINGH
Project Type	General Proposal
Project Location	Bandana Singh
Project Status	Approved
Project Date	10/10/2020

AREA INDEX

Category	Area (Sq.M)
Total Area	117.25
Proposed Building Area	117.25
Proposed Road Area	117.25
Proposed Green Area	117.25
Proposed Water Body Area	117.25
Proposed Other Area	117.25
Proposed Total Area	117.25

COLOR INDEX

Color	Description
Green	Proposed Green Area
Yellow	Proposed Road Area
Blue	Proposed Water Body Area
Red	Proposed Other Area

Color Index Table 40-1

Color	No. of Items	Total Area (Sq.M)	Total Area (Sq.M)	Total Area (Sq.M)
Green	1	117.25	117.25	117.25
Yellow	1	117.25	117.25	117.25
Blue	1	117.25	117.25	117.25
Red	1	117.25	117.25	117.25