

Proposal Basic Information

| | |
|-------------------|----------------------|
| Proposal File No. | CMC/BI/0211/W30/2022 |
| Owner Name | BALIKA DEVI |
| Khata No. | 43 |
| Plot No. | 1247 |
| Village Name | Telidih |
| Use | Mixed |
| SubUse | Res+Comm |

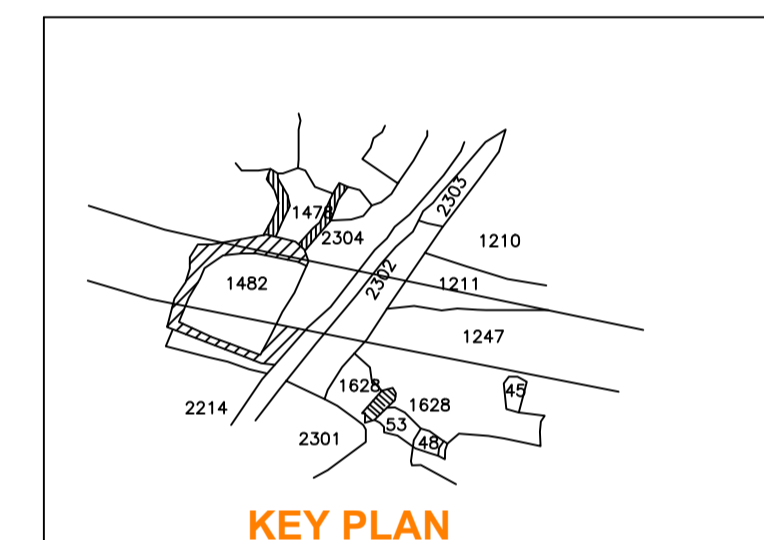
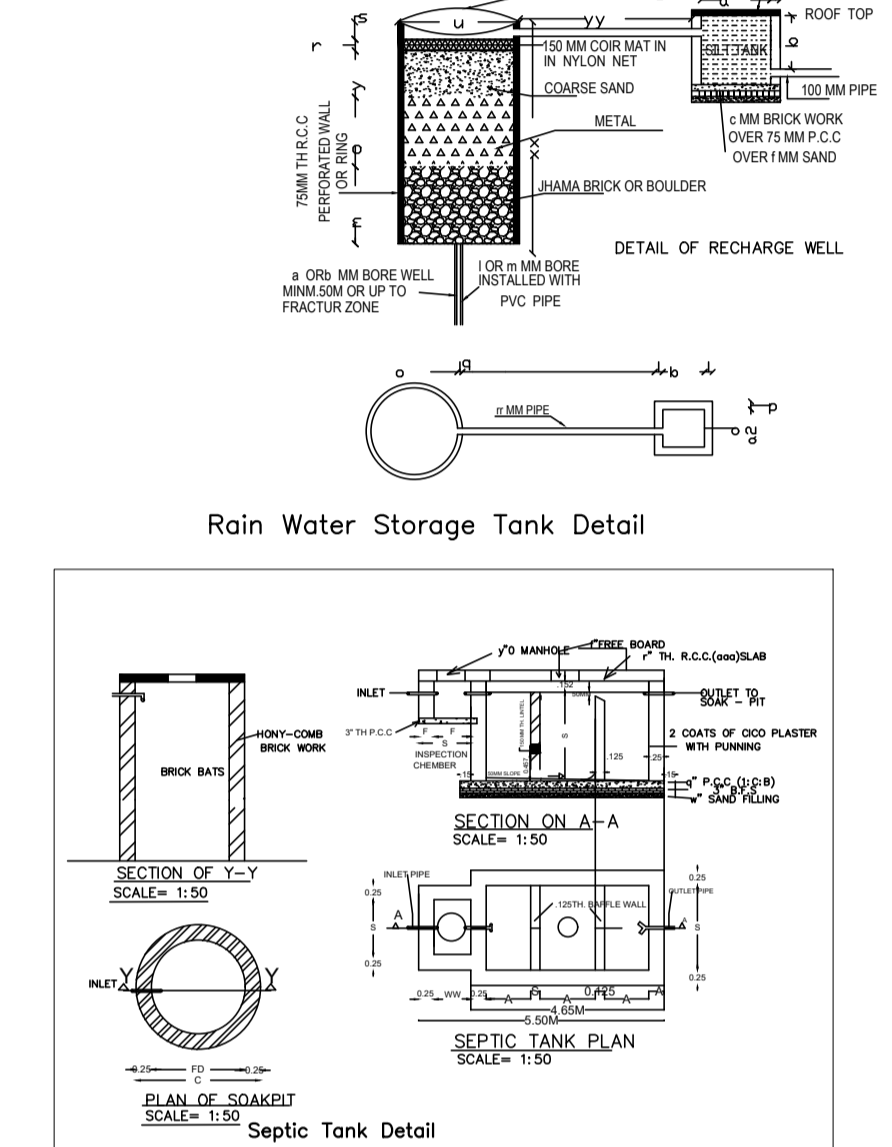
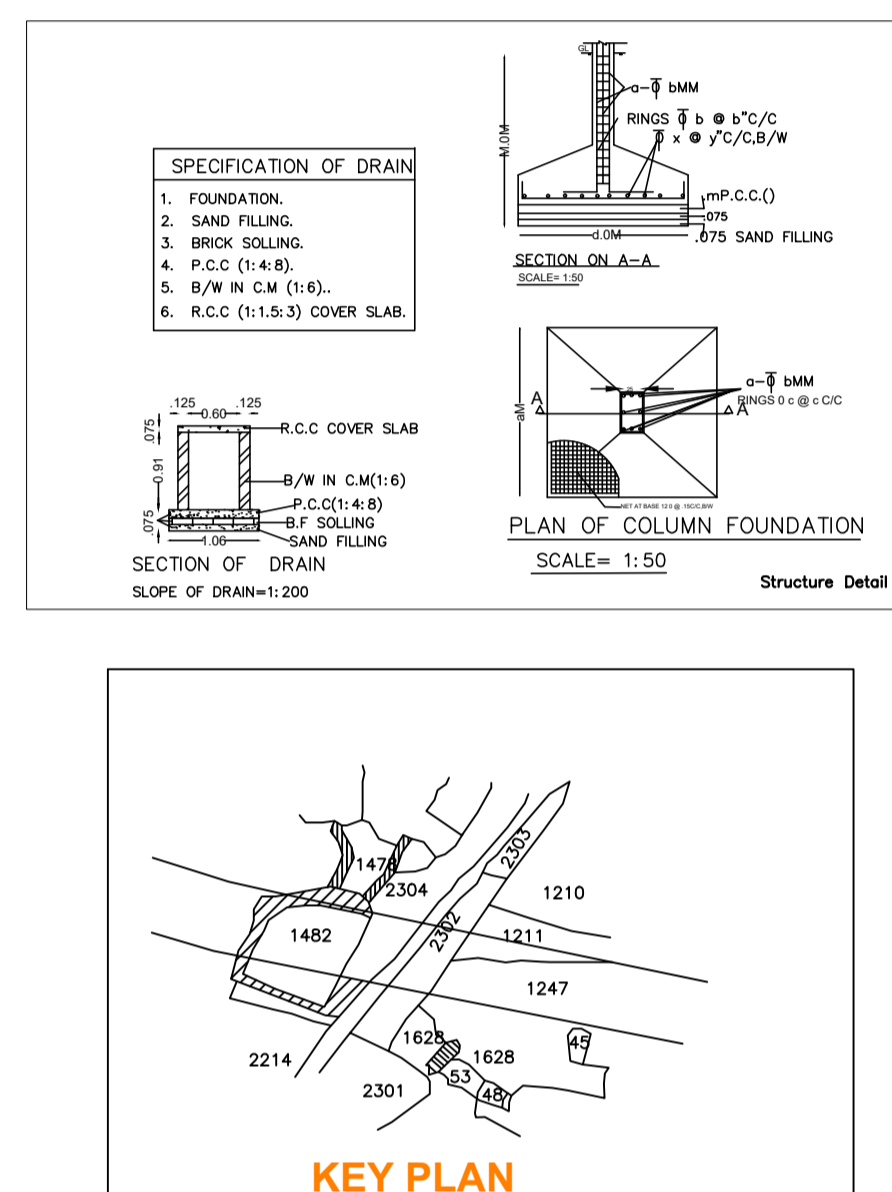
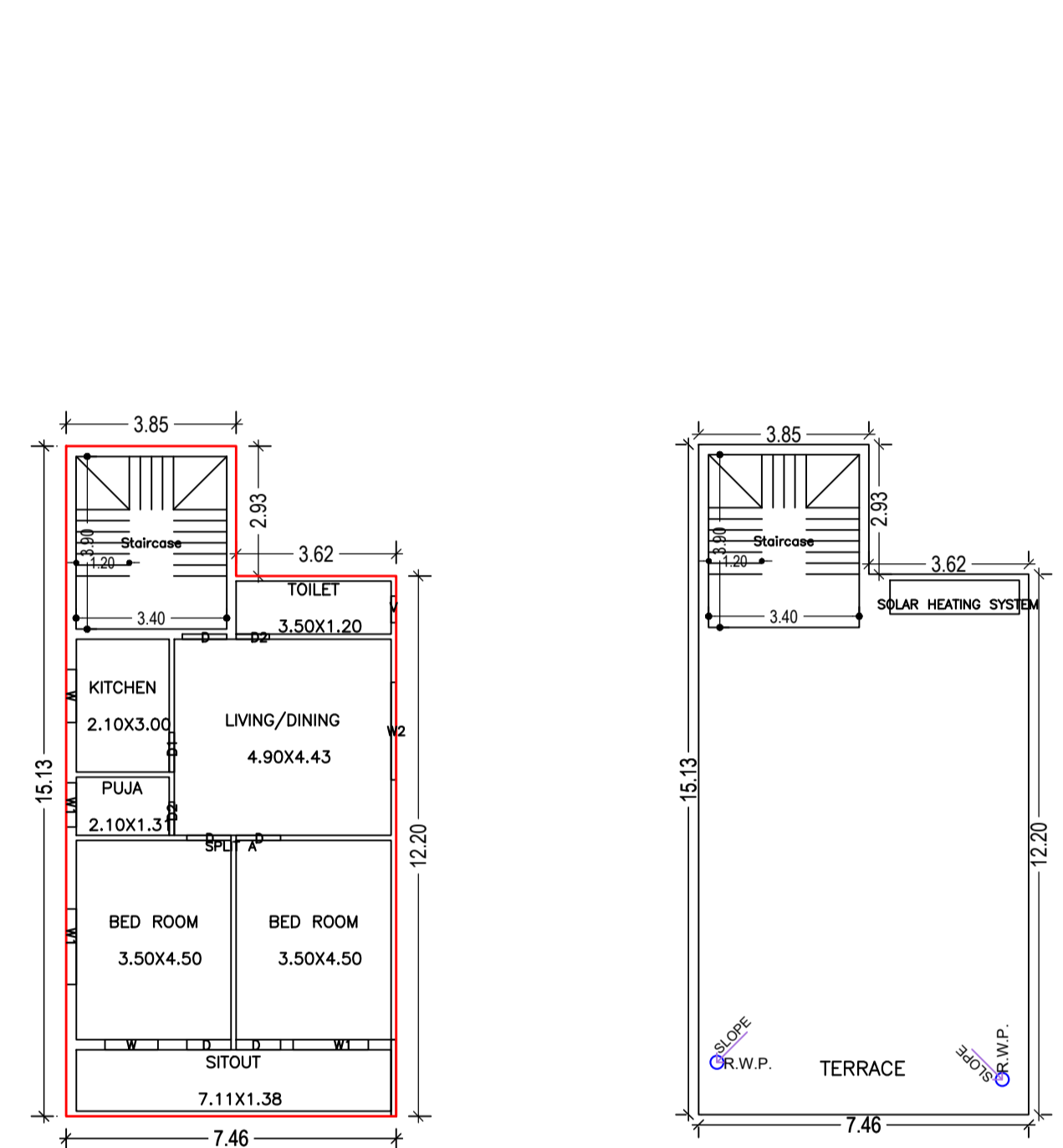
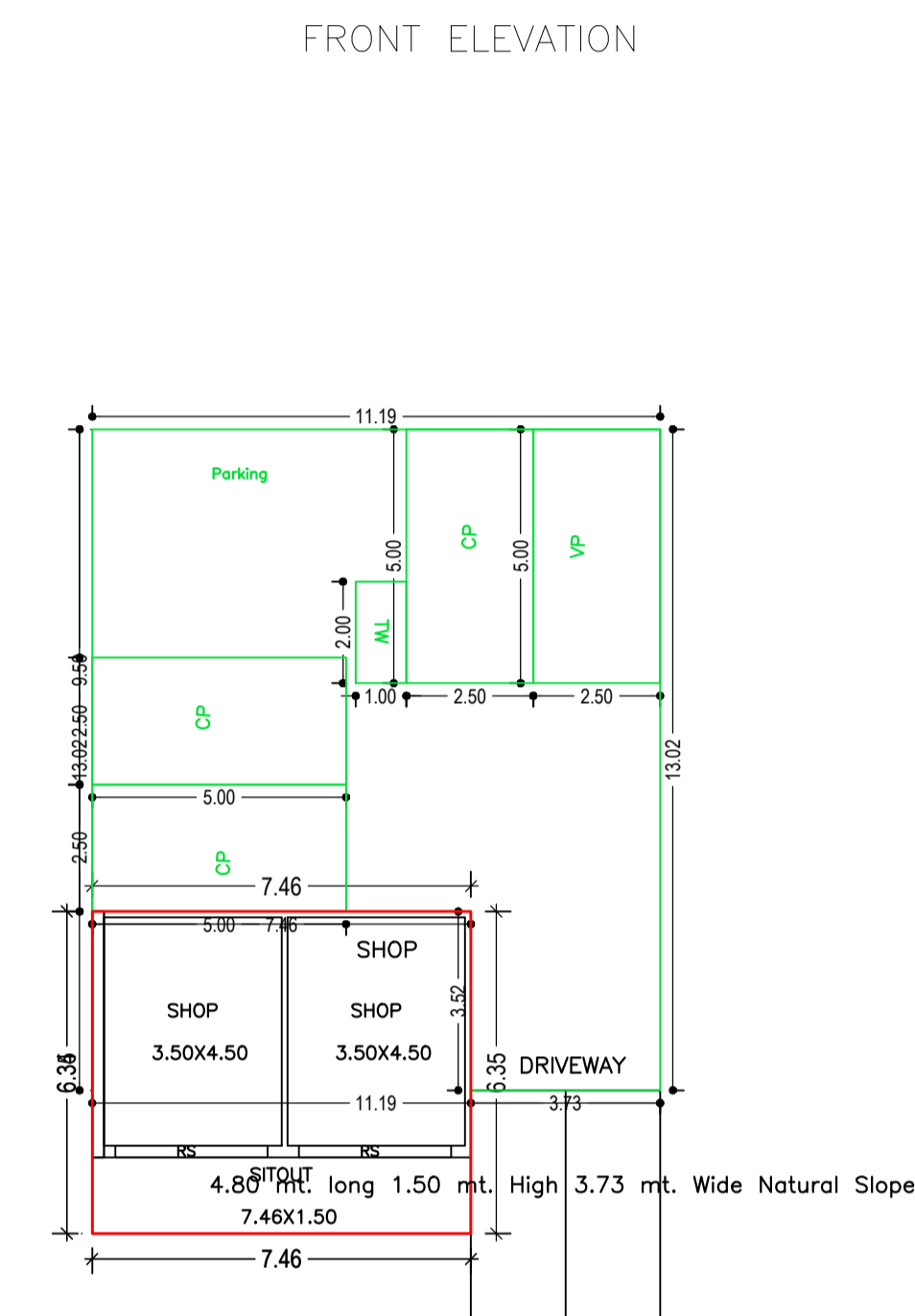

AREA STATEMENT CHAS

| | | | |
|------------------------------|------------------------------|--|----------|
| Region | JHARKHAND URBAN LOCAL BODIES | Plot Use | Mixed |
| District | BOKARO | Plot SubUse | Res+Comm |
| Authority | CHAS MUNICIPAL CORPORATION | PlotNearbyReligiousStructure | NA |
| Inward No. | CMC/BI/0211/W30/2022 | PlotSubPlot No. | 1247 |
| Application Type | General Proposal | North Road Width - NH-23 ROAD | |
| Project Type | Building Permission | South Road Width - PARADIGMS ROAD & MTR WIDE | |
| Nature of Development | New | East CTS No. - LATE RADHA NATH MAHATO | |
| Location of Development Area | New | West CTS No. - LATE ASHUTOSH MAHATO | |

AREA DETAILS

| | | | |
|---|----------------|--------|--------|
| AREA OF PLOT (Minimum) | (A) | SQ.MT. | 626.84 |
| NET AREA OF PLOT (Gross Plot Area - Deduction from Gross Plot Area) | (A) Deductions | | 626.84 |
| Deduction for Balance Plot Area/From Gross Plot Area | | | 66.42 |
| Common Plot | | | 66.42 |
| BALANCE AREA OF PLOT (Net Plot Area - Recreational/Amenity Area) | (A) Deductions | | 560.38 |
| PLOT AREA FOR COVERAGE (Net Plot Area) | (A) Deductions | | 626.84 |
| Plot Area for FAR (Net Plot Area + Road/Widening Area) | (A) Deductions | | 626.84 |

COVERAGE CHECK

| | |
|-------------------------------------|--------|
| Permissible Coverage Area (60.00 %) | 376.13 |
| Proposed Coverage Area (7.55 %) | 47.33 |
| Total Prop. Coverage Area (7.55 %) | 47.33 |
| Balance coverage area (52.45 %) | 328.77 |

FAR CHECK

| | |
|-------------------------|---------|
| Perm. FAR Area (2.50) | 1567.10 |
| Total Perm. FAR Area | 1567.10 |
| Residential FAR | 102.28 |
| Commercial FAR | 684.48 |
| Proposed FAR Area | 786.76 |
| Total Proposed FAR Area | 786.76 |
| Consumed FAR (Factor) | 1.26 |
| Balance FAR Area | 786.34 |

BUILT UP AREA CHECK

| | |
|------------------------------|--------|
| Total Proposed Built Up Area | 911.12 |
|------------------------------|--------|

ARCHITECT (Regd.)
ENGINEER (Regd.)
SUPERVISOR (Regd.)
OWNER (Regd.)

DINABANDHU RAJAK
BALIKA DEVI
LOCAL BODY

SCHEDULE OF DOOR:

| BUILDING NAME | NAME | LENGTH | HEIGHT | NOS |
|---------------|------------|--------|--------|-----|
| A (BALIKA) | D2 | 0.75 | 2.10 | 02 |
| A (BALIKA) | D1 | 0.90 | 2.10 | 01 |
| A (BALIKA) | D | 1.00 | 2.10 | 05 |
| A (BALIKA) | RS | 3.00 | 2.10 | 26 |
| A (BALIKA) | GLASS GATE | 3.81 | 2.10 | 02 |

SCHEDULE OF WINDOW/VENTILATION:

| BUILDING NAME | NAME | LENGTH | HEIGHT | NOS |
|---------------|------|--------|--------|-----|
| A (BALIKA) | V | 0.60 | 1.20 | 01 |
| A (BALIKA) | W1 | 1.00 | 1.20 | 01 |
| A (BALIKA) | W | 1.20 | 1.20 | 02 |
| A (BALIKA) | W1 | 1.70 | 1.20 | 02 |
| A (BALIKA) | W2 | 2.20 | 1.20 | 01 |

Balcony Calculations Table

| FLOOR | SIZE | AREA | TOTAL AREA |
|------------------|----------------------|------|------------|
| FIRST FLOOR PLAN | 0.90 X 10.96 X 1 X 1 | 9.86 | 9.86 |
| Total | - | - | 9.86 |

Building :A (BALIKA)

| Floor Name | Total Built Up Area (Sq.mt.) | Deductions (Area in Sq.mt.) | Proposed FAR Area (Sq.mt.) | Total FAR Area (Sq.mt.) | Total Consumed Additional FAR Area (Sq.mt.) | Tnmt (No.) |
|----------------|------------------------------|-----------------------------|----------------------------|-------------------------|---|------------|
| Basement Floor | 166.76 | 0.00 | 119.43 | 47.33 | 47.33 | 01 |
| Ground Floor | 316.11 | 0.00 | 0.00 | 316.11 | 316.11 | 01 |
| First Floor | 325.97 | 4.93 | 0.00 | 321.04 | 321.04 | 01 |
| Second Floor | 102.28 | 0.00 | 0.00 | 102.28 | 102.28 | 01 |
| Terrace Floor | 0.00 | 0.00 | 0.00 | 0.00 | 0.00 | 00 |
| Total | 911.12 | 4.93 | 119.43 | 102.28 | 684.48 | 786.76 |

Required Parking (Table 7a)

| Building Name | Type | SubUse | Area (Sq.mt.) | Units | Car | Two Wheeler |
|---------------|------------|--------------|---------------|-------|--------|-------------|
| A (BALIKA) | Commercial | Shop | >0 | 50 | 657.94 | 1 |
| | | ResComm Bldg | >0 | 1 | 1.00 | - |
| | | Residential | >0 | 1 | 1.00 | - |
| Total | | | | 10 | 11 | 1 |

Parking Check (Table 7b)

| Vehicle Type | Reqd. | Prop. |
|-----------------------|--------|--------|
| Car | No. | Area |
| Car | 11 | 137.51 |
| Total Car | 10 | 125.00 |
| Visitors Car Parking | - | 1 |
| Total Visitor Parking | 1 | 12.50 |
| Two Wheeler | - | 32 |
| Total Two Wheeler | 29 | 58.00 |
| Other Parking | - | 67.43 |
| Total | 195.50 | 355.44 |

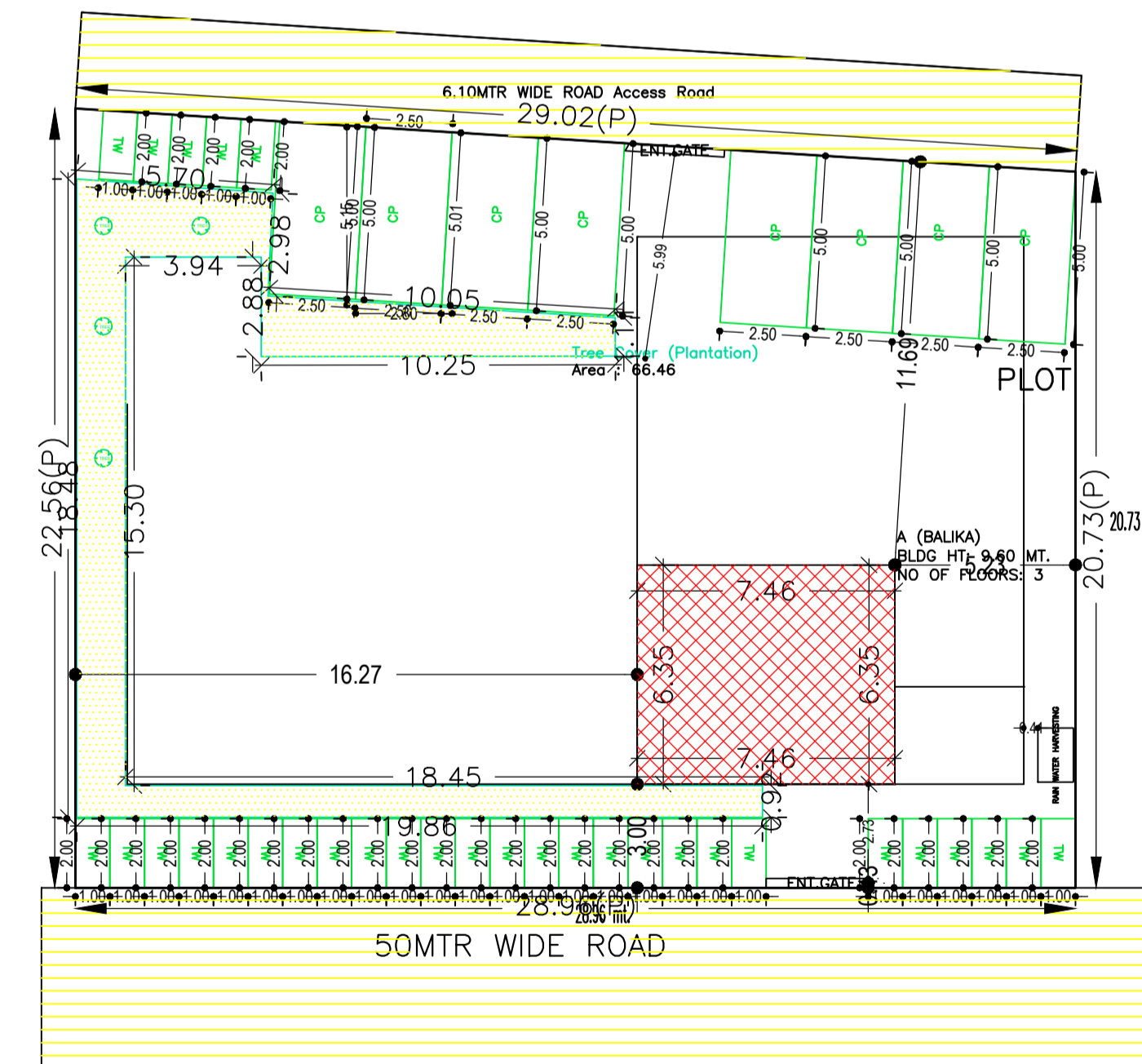

Building USE/SUBUSE Details

| Building Name | Building Use | Building SubUse | Building Structure |
|---------------|--------------|-----------------|--------------------|
| A (BALIKA) | Residential | ResComm Bldg | Non-Highrise |

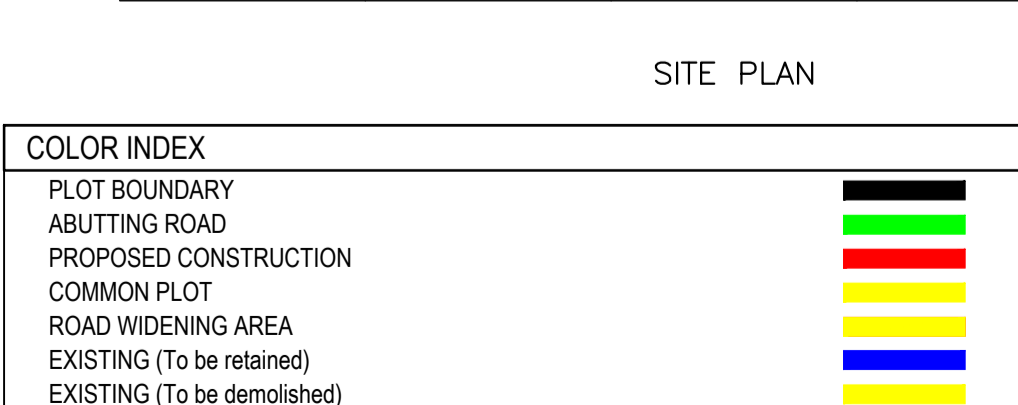

LTP NAME AND SIGNATURE

STRUCTURAL ENG'S NAME AND SIGNATURE

BUILDER NAME AND SIGNATURE

DIGITAL SIGNATURE

DINABANDHU RAJAK
CMC/ENG/001/2020

FAR & Tenement Details (Table 4c-1)

| Building | No. of Same Bldg | Total Built Up Area (Sq.mt.) | Deductions (Area in Sq.mt.) | | Proposed FAR Area (Sq.mt.) | | Total FAR Area (Sq.mt.) | Total Consumed Additional FAR Area (Sq.mt.) | Tnmt (No.) |
|-------------|------------------|------------------------------|-----------------------------|---------|----------------------------|------------|-------------------------|---|------------|
| | | | Balcony | Parking | Resi. | Commercial | | | |
| A (BALIKA) | 1 | 911.12 | 4.93 | 119.43 | 102.28 | 684.48 | 786.76 | 786.76 | 04 |
| Grand Total | 1 | 911.12 | 4.93 | 119.43 | 102.28 | 684.48 | 786.76 | 786.76 | 04 |

Buildingwise Floor FAR Details

| Floor Name | Building Name | | Total | |
|----------------|---------------------------------|----------------------------|---------------------------------------|-------------------------|
| | Proposed Built Up Area (Sq.mt.) | Proposed FAR Area (Sq.mt.) | Total Proposed Built Up Area (Sq.mt.) | Total FAR Area (Sq.mt.) |
| Basement Floor | 166.76 | 47.33 | 166.76 | 47.33 |
| Ground Floor | 316.11 | 316.11 | 316.11 | 316.11 |
| First Floor | 325.97 | 321.04 | 325.97 | 321.04 |
| Second Floor | 102.28 | 102.28 | 102.28 | 102.28 |
| Terrace Floor | 0.00 | 0.00 | 0.00 | 0.00 |
| Total: | 911.12 | 786.76 | 911.12 | 786.76 |

UnitBUA Table for Building :A (BALIKA)

| FLOOR | Name | UnitBUA Type | UnitBUA Area | Carpet Area | No. of Rooms | No. of Tenement |
|----------------|---------|--------------|--------------|-------------|--------------|-----------------|
| BASEMENT FLOOR | SHOP | SHOP | 47.33 | 46.22 | 3 | 1 |
| GROUND FLOOR | SHOP | SHOP | 316.11 | 316.04 | 15 | 1 |
| SECOND FLOOR | SPLIT A | FLAT | 102.28 | 102.08 | 7 | 1 |
| FIRST FLOOR | SHOP | SHOP | 325.97 | 315.70 | 15 | 1 |
| Total: | - | - | 791.69 | 780.04 | 40 | 4 |