

Proposal Basic Information	
Proposal File No.	CMC/BP/0257/W02/2022
Owner Name	1. RANJAN KUMAR SHARMA 2. MANISH KUMAR SHARMA
Khata No	387
Plot No	612/7901
Village Name	Chas
Use	Residential
SubUse	Bungalow/ Dwelling / Non Apartment

AREA STATEMENT CHAS MUNICIPAL CORPORATION		VERSION NO. : 1.0.64
PROJECT DETAIL:		VERSION DATE: 16/10/2020
Region: JHARKHAND URBAN LOCAL BODIES	Plot Use: Residential	
District: BOKARO	Plot SubUse: Bungalow/ Dwelling / Non Apartment	
Authority: CHAS MUNICIPAL CORPORATION	PlotNearby/ReligiousStructure: NA	
Inward_No: CMC/BP/0257/W02/2022	Plot/SubPlot No: 612/7901	
Application Type: General Proposal	North: Plot No. - DAMODAR MANDAL	
Project Type: Building Permission	South: Road Width - 9.14 M ROAD	
Nature of Development: New	East: Plot No. - GOVARDHAN MANDAL	
Location of Development Area: Old Area	West: Plot No. - AASHU MANDAL	
AREA DETAILS:		SQ.MT.
AREA OF PLOT (Minimum)	(A)	60.73
NET AREA OF PLOT(Gross Plot Area - Deduction from Gross Plot area)	(A-Deductions)	60.73
Deduction for Balance Plot Area(from Gross Plot Area)		
Common Plot		7.72
Total		7.72
BALANCE AREA OF PLOT(Net Plot Area - Recreational/Amenity space)	(A-Deductions)	53.00
PLOT AREA FOR COVERAGE(Net Plot Area)	(A-Deductions)	60.73
Plot Area for FAR (Net Plot Area + RoadWidening Area)	(A-Deductions)	60.73
COVERAGE CHECK		
Permissible Coverage area (70.00 %)		42.51
Proposed Coverage Area (59.79 %)		36.31
Total Prop. Coverage Area (59.79 %)		36.31
Balance coverage area (10.21 %)		6.20
FAR CHECK		
Perm. FAR Area (2.50)		151.82
Total Perm. FAR area		151.82
Residential FAR		72.62
Proposed FAR Area		72.62
Total Proposed FAR Area		72.62
Consumed FAR (Factor)		1.20
Balance FAR Area		79.20
BUILT UP AREA CHECK		
Total Proposed BuiltUp Area		72.62
ARCHITECT (Regd)	RAVI KUMAR	
ENGINEER (Regd)		
SUPERVISOR (Regd)		
OWNER (Regd)	1. RANJAN KUMAR SHARMA 2. MANISH KUMAR SHARMA	
DEVELOPMENT AUTHORITY		LOCAL BODY

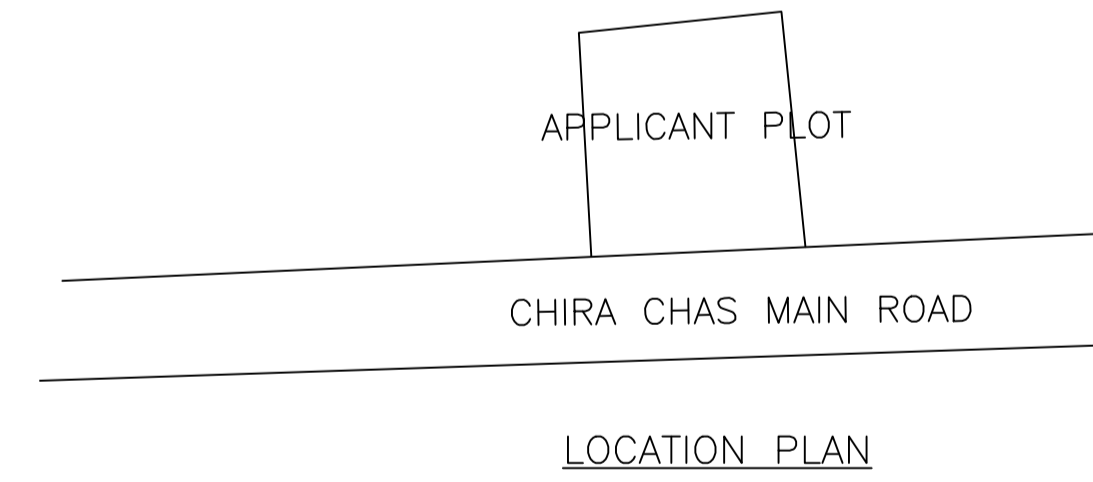
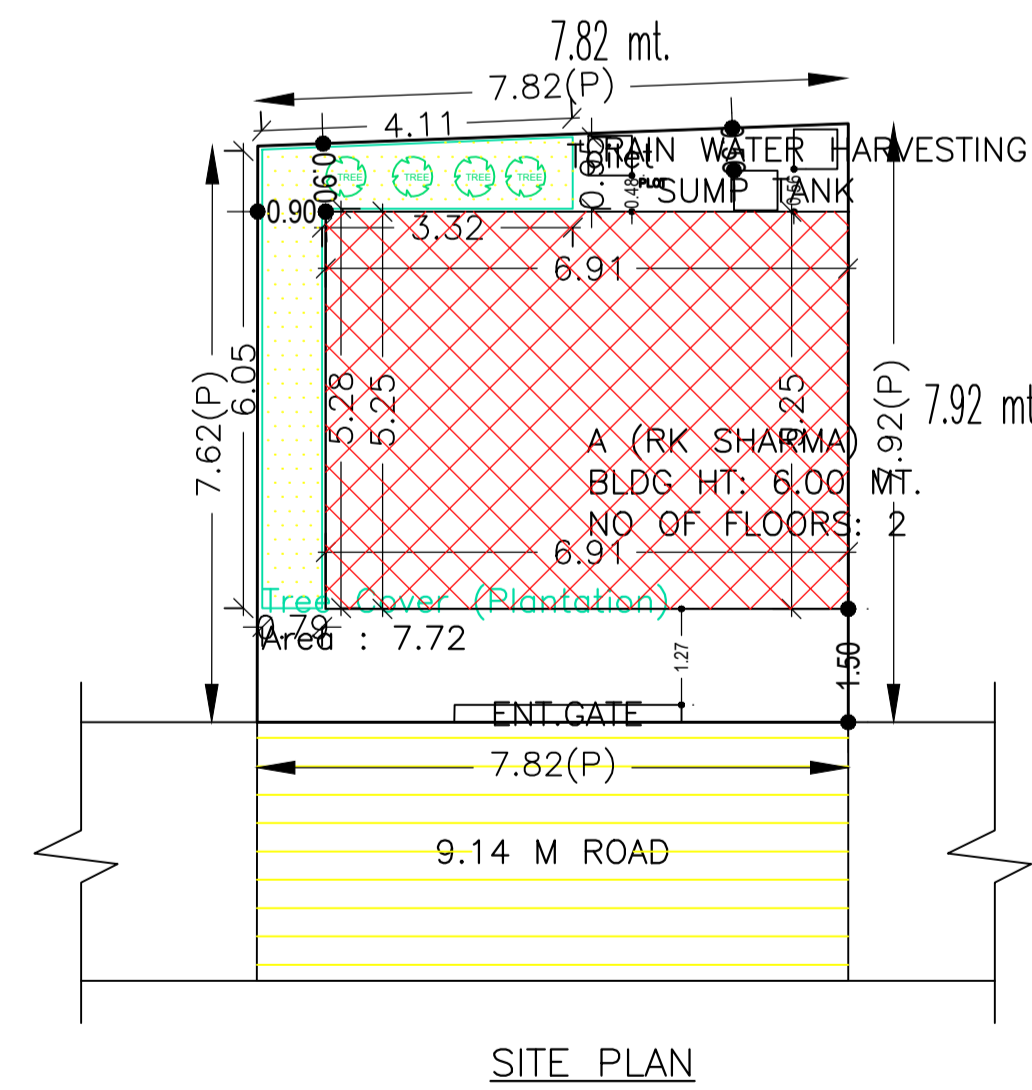
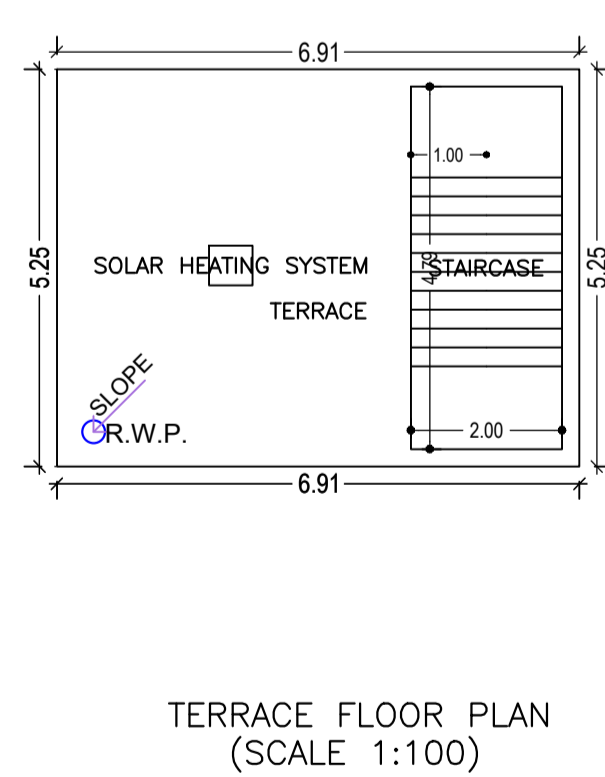
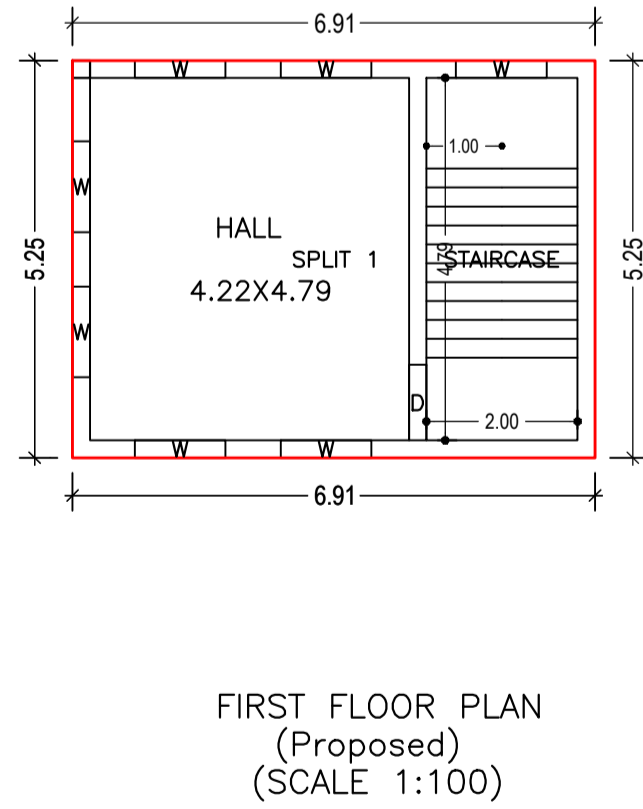
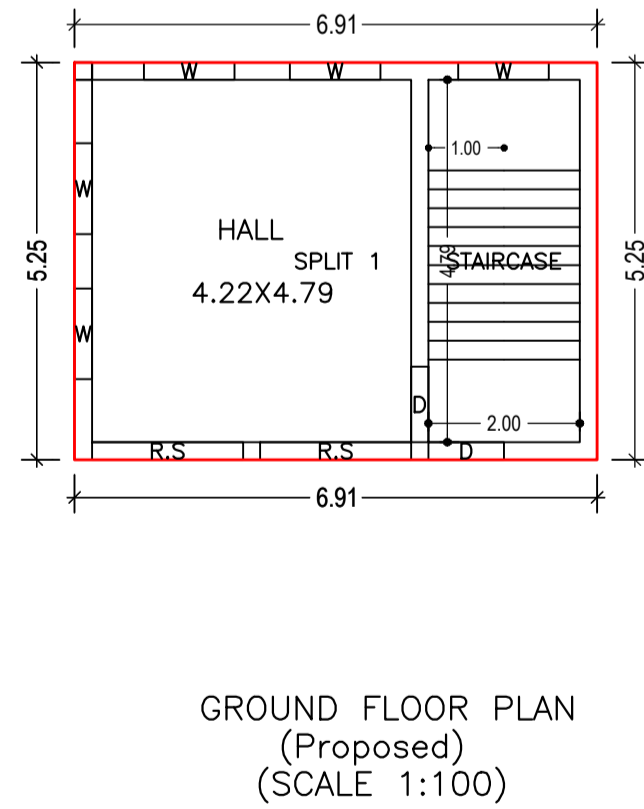
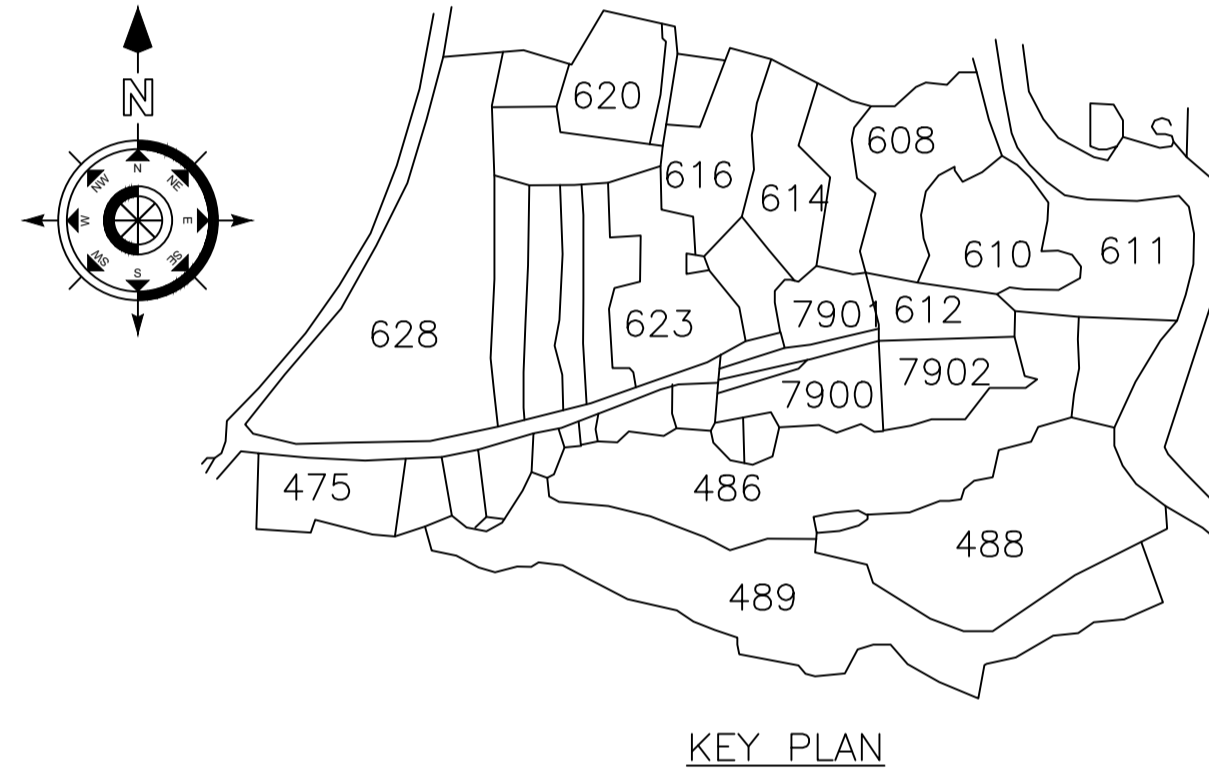
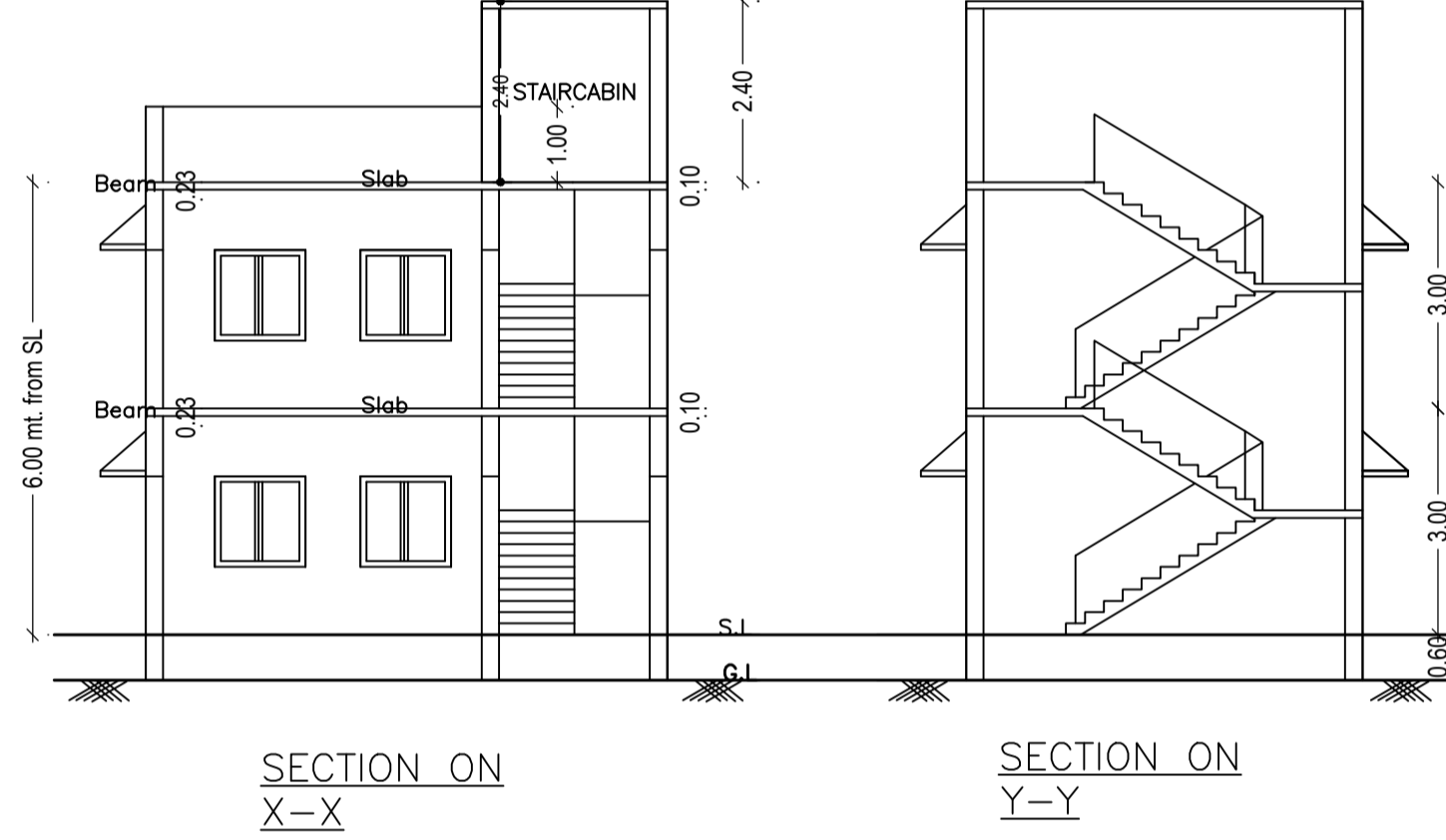
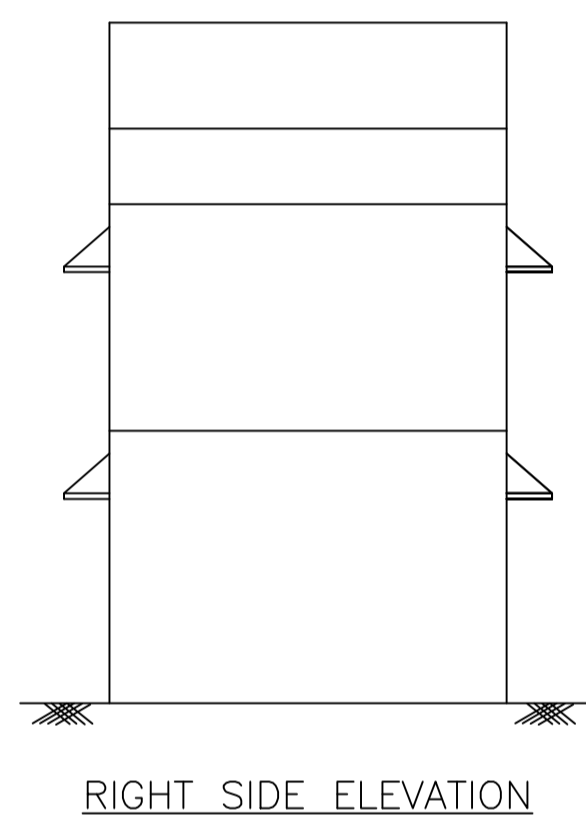
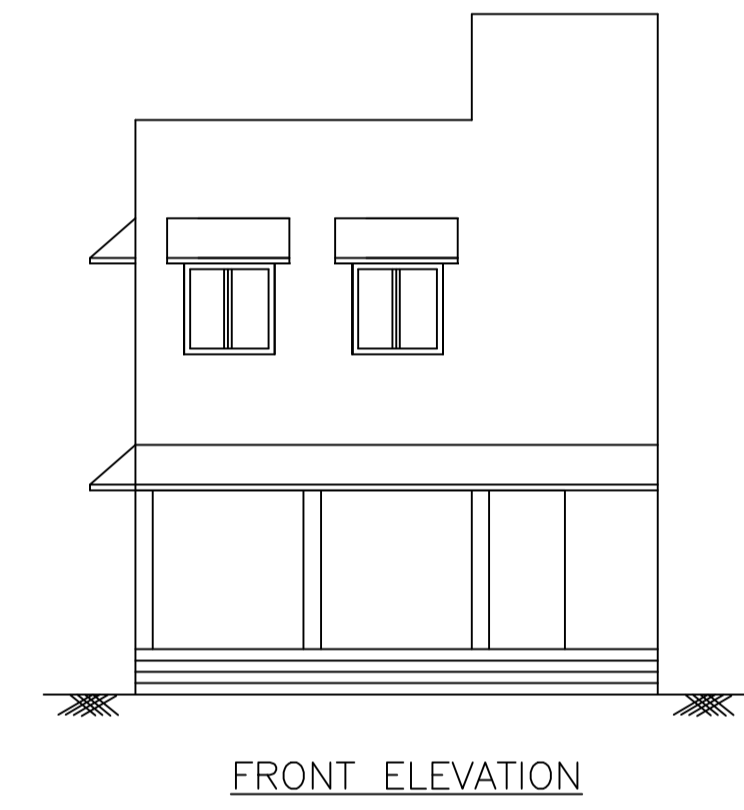

Buildingwise Floor FAR Details

Floor Name	Building Name A (RK SHARMA)		Total	
	Proposed Built Up Area (Sq.mt.)	Proposed FAR Area (Sq.mt.)	Total Proposed Built Up Area (Sq.mt.)	Total FAR Area (Sq.mt.)
Ground Floor	36.31	36.31	36.31	36.31
First Floor	36.31	36.31	36.31	36.31
Terrace Floor	0.00	0.00	0.00	0.00
Total :	72.62	72.62	72.62	72.62

Building :A (RK SHARMA)

Floor Name	Total Built Up Area (Sq.mt.)	Proposed FAR Area (Sq.mt.) Resi.	Total FAR Area (Sq.mt.)	Total Consumed Additional FAR Area (Sq.mt.)	Trmt (No.)
Ground Floor	36.31	36.31	36.31	36.31	01
First Floor	36.31	36.31	36.31	36.31	00
Terrace Floor	0.00	0.00	0.00	0.00	00
Total :	72.62	72.62	72.62	72.62	01
Total Number of Same Buildings :	1				
Total :	72.62	72.62	72.62	72.62	01

UnitBUA Table for Building :A (RK SHARMA)

FLOOR	Name	UnitBUA Type	UnitBUA Area	Carpet Area	No. of Rooms	No. of Tenement
GROUND FLOOR PLAN	SPLIT 1	FLAT	72.62	72.52	1	1
FIRST FLOOR PLAN	SPLIT 1	FLAT	0.00	0.00	1	0
Total:	-	-	72.62	72.52	2	1

FAR & Tenement Details (Table 4c-1)

Building	No. of Same Bldg	Total Built Up Area (Sq.mt.)	Proposed FAR Area (Sq.mt.) Resi.	Total FAR Area (Sq.mt.)	Total Consumed Additional FAR Area (Sq.mt.)	Trmt (No.)
A (RK SHARMA)	1	72.62	72.62	72.62	72.62	01
Grand Total :	1	72.62	72.62	72.62	72.62	01

SCHEDULE OF DOOR:

BUILDING NAME	NAME	LENGTH	HEIGHT	NOS
A (RK SHARMA)	D	1.00	2.10	02
A (RK SHARMA)	R.S	2.00	2.10	02

SCHEDULE OF WINDOW/VENTILATION:

BUILDING NAME	NAME	LENGTH	HEIGHT	NOS
A (RK SHARMA)	W	1.20	1.20	12

Building USE/SUBUSE Details

Building Name	Building Use	Building SubUse	Building Structure
A (RK SHARMA)	Residential	Bungalow/ Dwelling / Non Apartment	Non-Highrise

COLOR INDEX

PLOT BOUNDARY	Black
ABUTTING ROAD	Red
PROPOSED CONSTRUCTION	Green
COMMON PLOT	Blue
ROAD WIDENING AREA	Yellow
EXISTING (To be retained)	Light Blue
EXISTING (To be demolished)	Light Yellow

LTP NAME AND SIGNATURE

RAVI KUMAR
CMC/DFTM/0024/2017

STRUCTURAL ENG'S NAME AND SIGNATURE

BUILDER NAME AND SIGNATURE

DIGITAL SIGNATURE