

Proposal Basic Information

Proposal File No.	CMC/BP/0342/W31/2022
Owner Name	RAM KUMARI DEVI
Khata No	203,242
Plot No	1712,1713
Village Name	Kandra
Use	Residential
SubUse	Bungalow/ Dwelling / Non Apartment

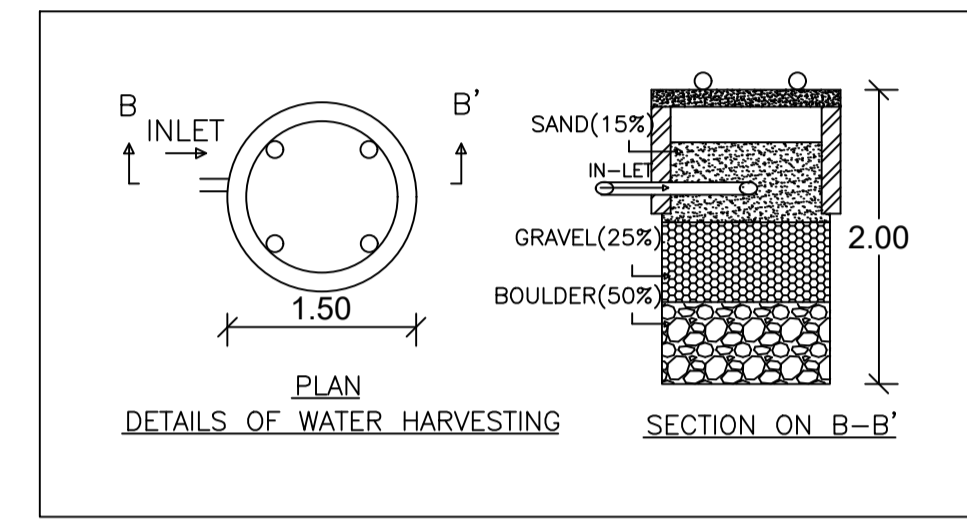

AREA STATEMENT CHAS MUNICIPAL CORPORATION	VERSION NO.: 1.0.65	SQ.MT.
PROJECT DETAIL:	VERSION DATE: 16/10/2020	
Region: JHARKHAND URBAN	Plot Use: Residential	
LOCAL BODIES	Plot SubUse: Bungalow/ Dwelling / Non Apartment	
District: BOKARO	PlotNearbyReligiousStructure: NA	
Authority: CHAS MUNICIPAL CORPORATION		
Inward No: CMC/BP/0342/W31/2022	Plot/SubPlot No: 1712,1713	
Application Type: General Proposal	North: Road Width - ROAD	
Project Type: Building Permission	South: Plot No. - PLOTING 146	
Nature of Development: New	East: Road Width - 9.14 MTR WIDE ROAD	
Location of Development Area: New Area	West: Plot No. - PLOTING 155	
AREA OF PLOT (Minimum)	(A)	202.29
NET AREA OF PLOT (Gross Plot Area - Deduction from Gross Plot area)	(A-Deductions)	202.29
Deduction for Balance Plot Area (from Gross Plot Area)		
Common Plot		13.02
Total		13.02
BALANCE AREA OF PLOT (Net Plot Area - Recreational/Amenity space)	(A-Deductions)	189.27
PLOT AREA FOR COVERAGE (Net Plot Area)	(A-Deductions)	202.29
Plot Area for FAR (Net Plot Area + Road Widening Area)	(A-Deductions)	202.29
COVERAGE CHECK		
Permissible Coverage area (70.00 %)		141.60
Proposed Coverage Area (63.32 %)		128.08
Total Prop. Coverage Area (63.32 %)		128.08
Balance coverage area (6.68 %)		13.52
FAR CHECK		
Perm. FAR Area (2.500)		505.72
Total Perm. FAR area		505.72
Residential FAR		256.17
Proposed FAR Area		256.17
Total Proposed FAR Area		256.17
Consumed FAR (Factor)		1.27
Balance FAR Area		249.55
BUILT UP AREA CHECK		
Total Proposed BuiltUp Area		256.16
ARCHITECT (Regd)		AMRIT KUMAR MAHATO
ENGINEER (Regd)		
SUPERVISOR (Regd)		RAM KUMARI DEVI
OWNER (Regd)		
DEVELOPMENT AUTHORITY		LOCAL BODY

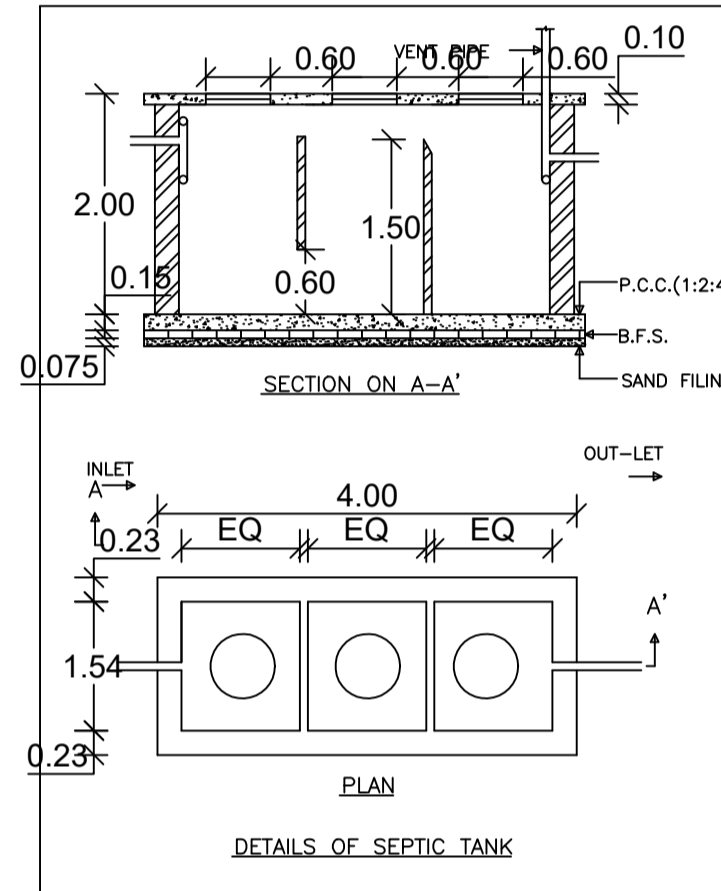
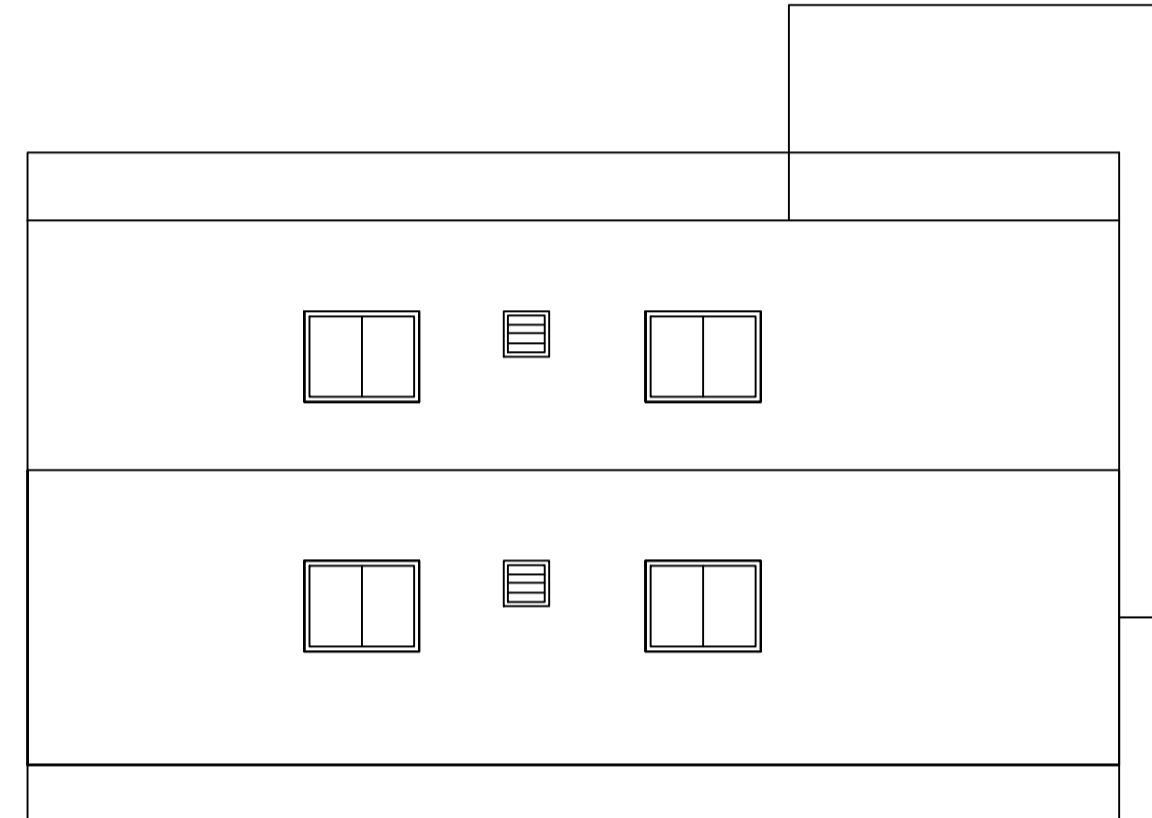
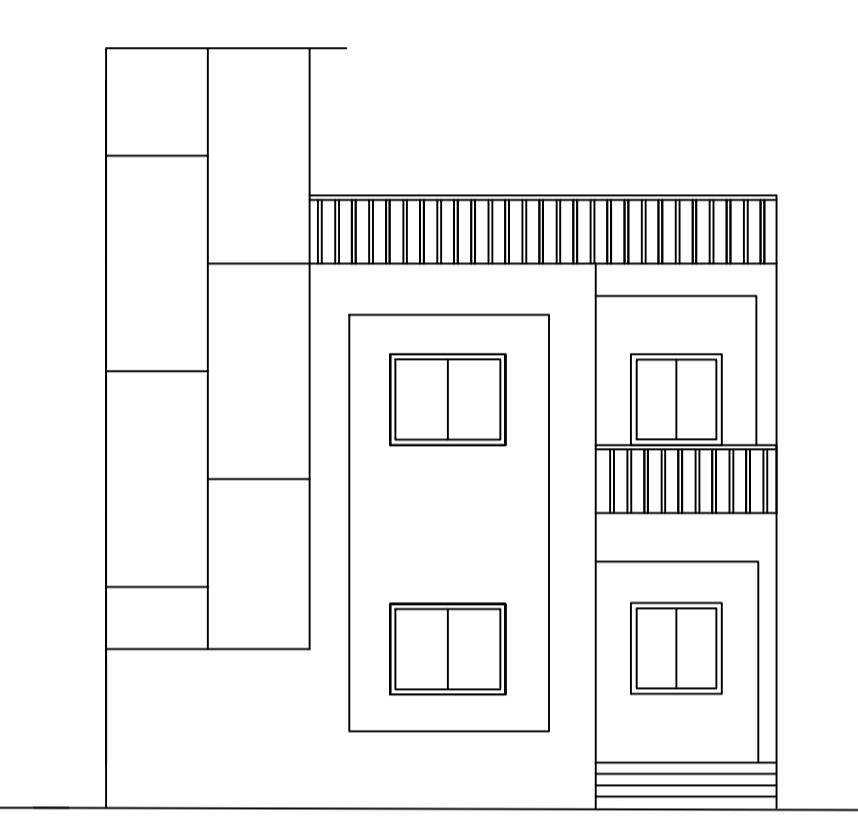
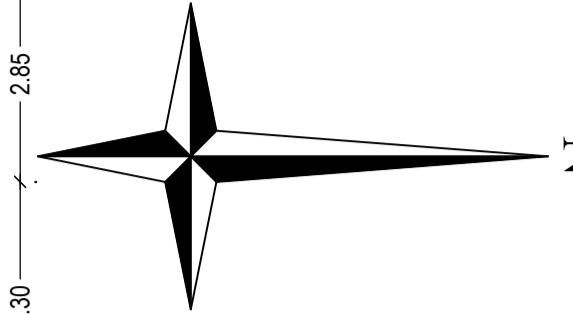
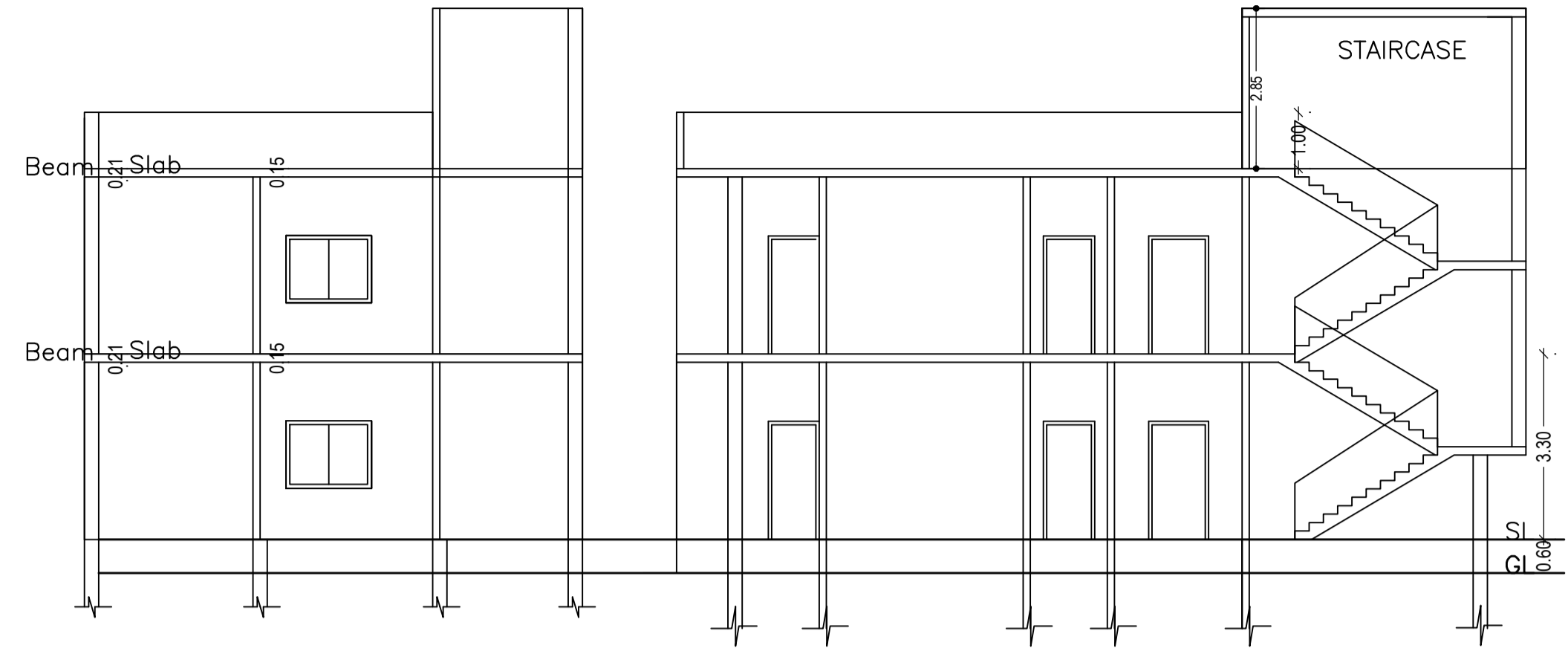
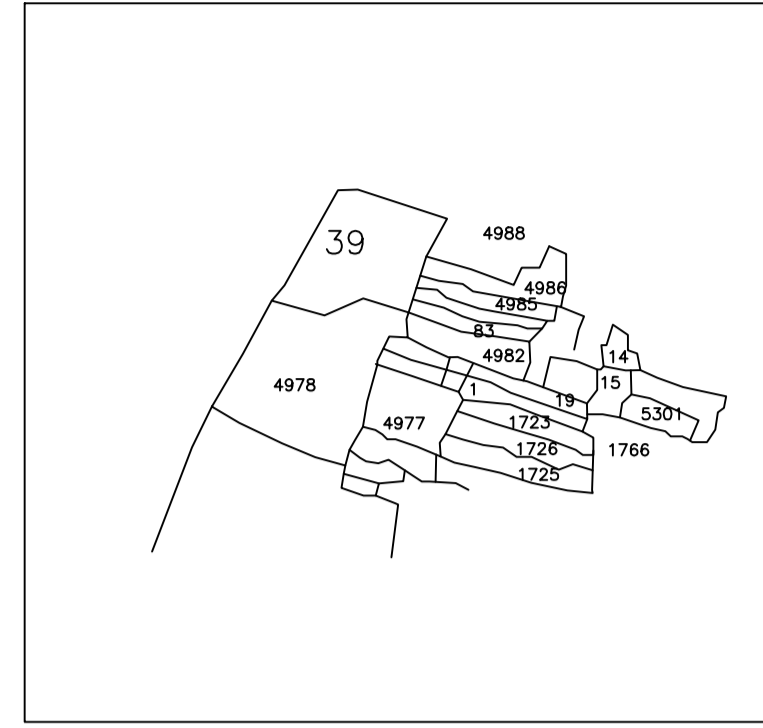
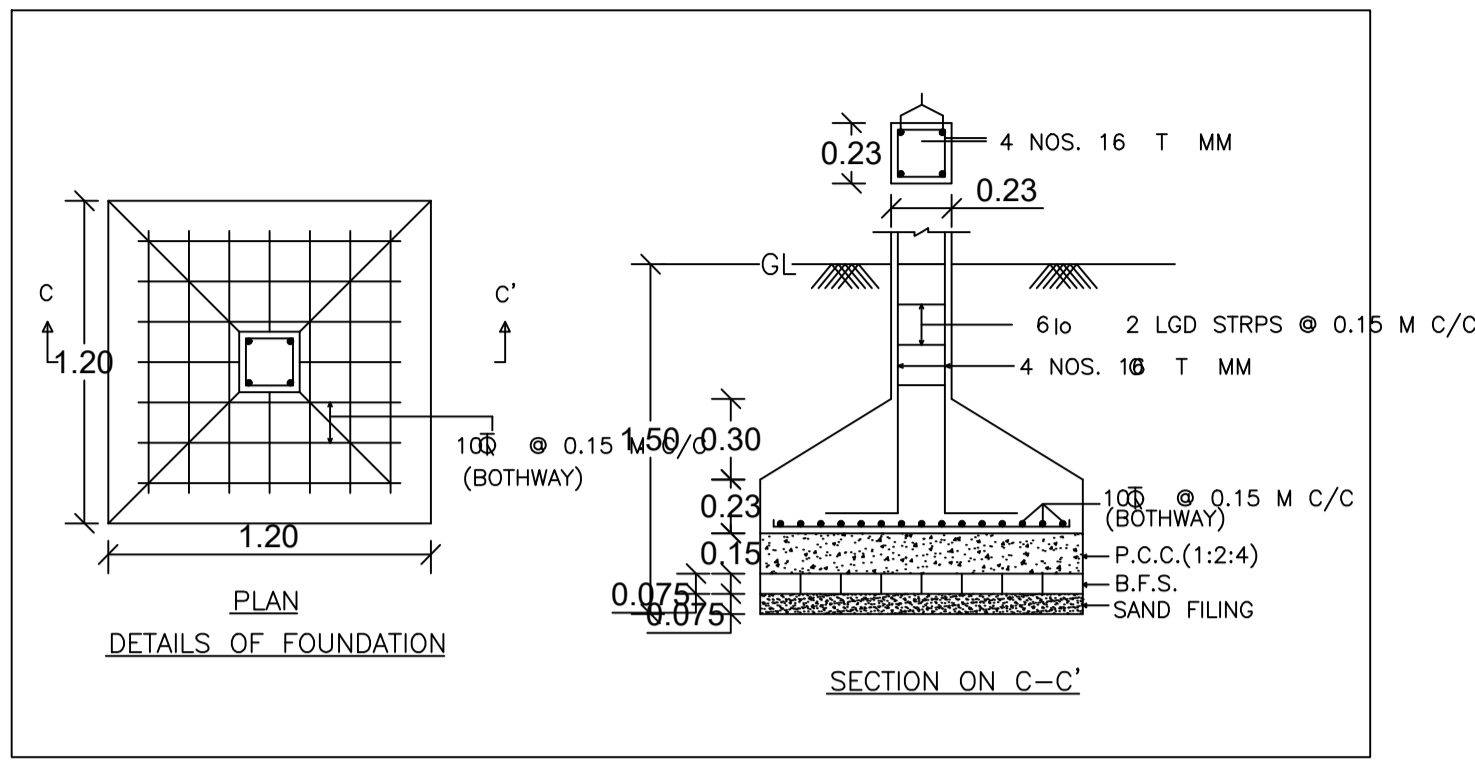
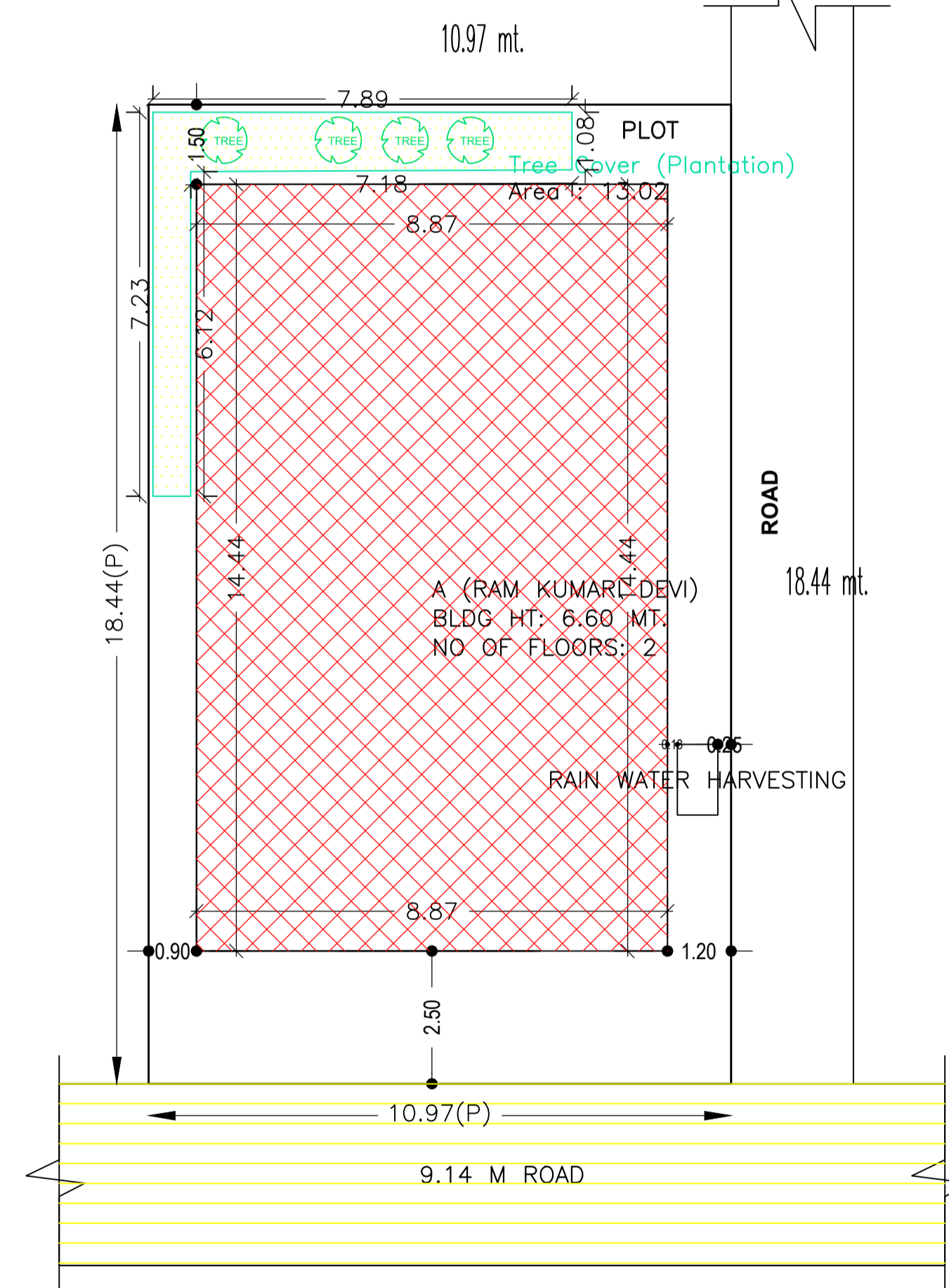
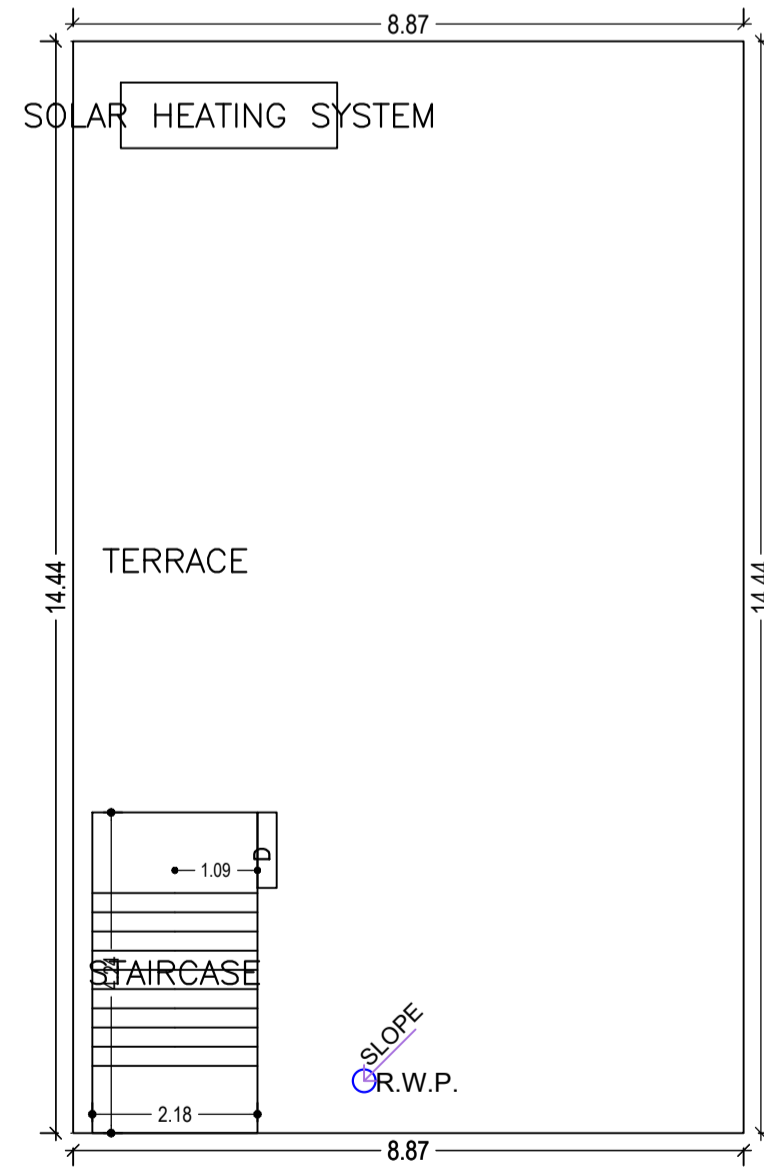
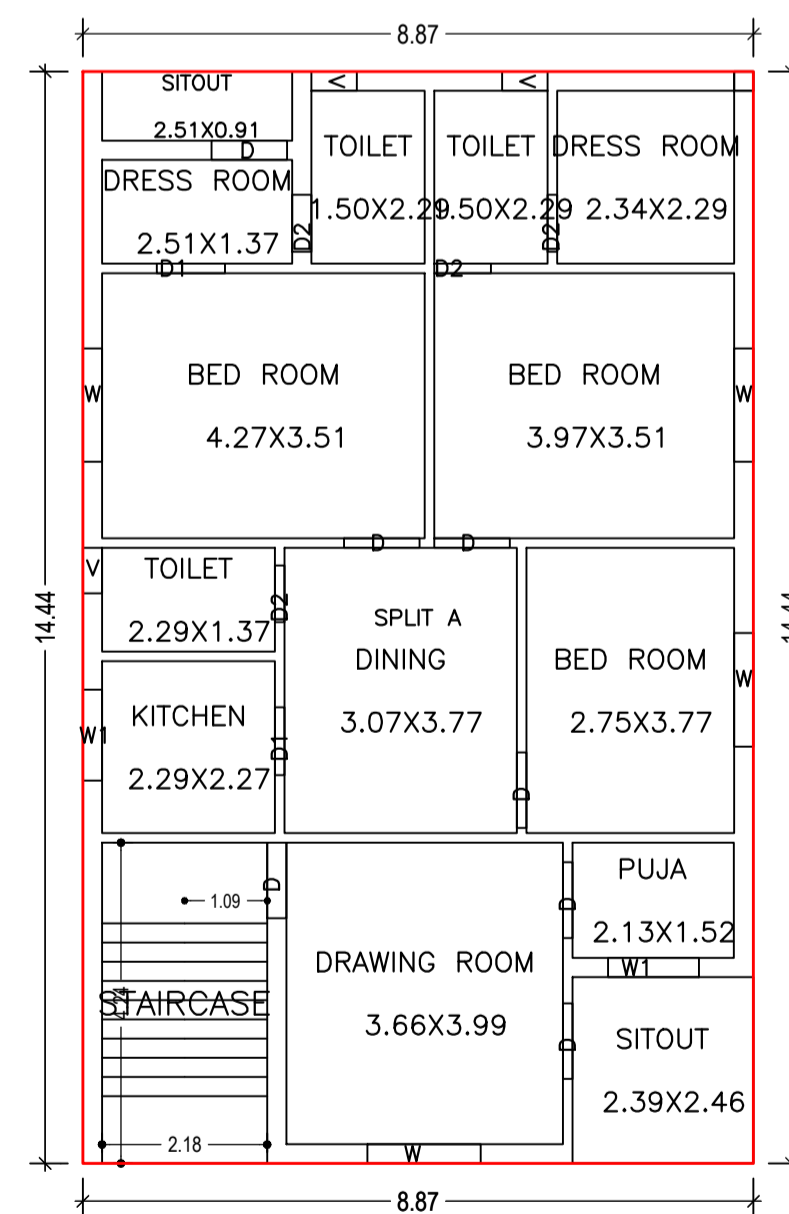
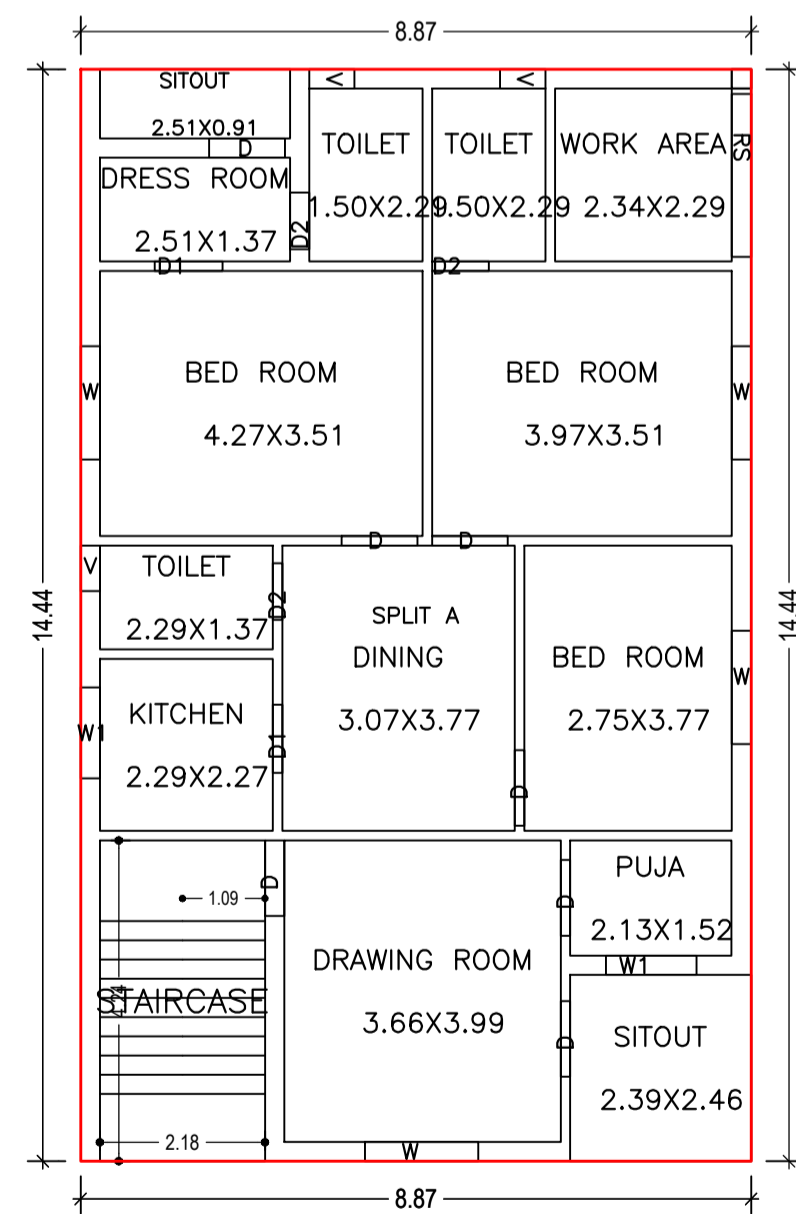

SCHEDULE OF DOOR:

BUILDING NAME	NAME	LENGTH	HEIGHT	NOS
A (RAM KUMARI DEVI)	D2	0.75	2.10	07
A (RAM KUMARI DEVI)	D1	0.90	2.10	04
A (RAM KUMARI DEVI)	D	1.00	2.10	14
A (RAM KUMARI DEVI)	RS	2.16	2.10	01

SCHEDULE OF WINDOW/VENTILATION:

BUILDING NAME	NAME	LENGTH	HEIGHT	NOS
A (RAM KUMARI DEVI)	V	0.60	1.20	06
A (RAM KUMARI DEVI)	W1	1.20	1.20	04
A (RAM KUMARI DEVI)	W	1.50	1.20	08

Building :A (RAM KUMARI DEVI)

Floor Name	Total Built Up Area (Sq.mt.)	Proposed FAR Area (Sq.mt.) Resi.	Total FAR Area (Sq.mt.)	Total Consumed Additional FAR Area (Sq.mt.)	Tnmt (No.)
Ground Floor	128.08	128.08	128.08	128.08	01
First Floor	128.08	128.08	128.08	128.08	00
Terrace Floor	0.00	0.00	0.00	0.00	00
Total :	256.16	256.16	256.16	256.16	01
Total Number of Same Buildings :	1				
Total :	256.16	256.16	256.16	256.16	01

Buildingwise Floor FAR Details

Floor Name	Building Name A (RAM KUMARI DEVI)				Total FAR Area (Sq.mt.)
	Proposed Built Up Area (Sq.mt.)	Proposed FAR Area (Sq.mt.)	Total Proposed Built Up Area (Sq.mt.)	Total FAR Area (Sq.mt.)	
Ground Floor	128.08	128.08	128.08	128.08	
First Floor	128.08	128.08	128.08	128.08	
Terrace Floor	0.00	0.00	0.00	0.00	
Total :	256.16	256.16	256.16	256.16	

FAR & Tenement Details (Table 4c-1)

Building	No. of Same Bldg	Total Built Up Area (Sq.mt.)	Proposed FAR Area (Sq.mt.) Resi.	Total FAR Area (Sq.mt.)	Total Consumed Additional FAR Area (Sq.mt.)	Tnmt (No.)
A (RAM KUMARI DEVI)	1	256.16	256.16	256.16	256.16	01
Grand Total :	1	256.16	256.16	256.16	256.16	01

UnitBUA Table for Building :A (RAM KUMARI DEVI)

FLOOR	Name	UnitBUA Type	UnitBUA Area	Carpet Area	No. of Rooms	No. of Tenement
GROUND FLOOR	SPLIT A	FLAT	256.17	256.04	14	1
FIRST FLOOR	SPLIT A	FLAT	0.00	0.00	14	0
Total:	-	-	256.17	256.04	28	1

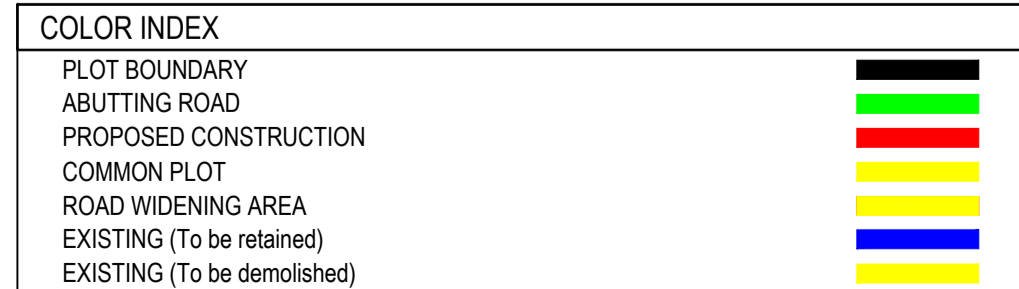

LTP NAME AND SIGNATURE	STRUCTURAL ENG'S NAME AND SIGNATURE	BUILDER NAME AND SIGNATURE	DIGITAL SIGNATURE
AMRIT KUMAR MAHATO CMC/DFTMN/0004/2019			

Building USE/SUBUSE Details

Building Name	Building Use	Building SubUse	Building Structure
A (RAM KUMARI DEVI)	Residential	Bungalow/ Dwelling / Non Apartment	Non-Highrise