

Project Title : NASRIN PERVEEN

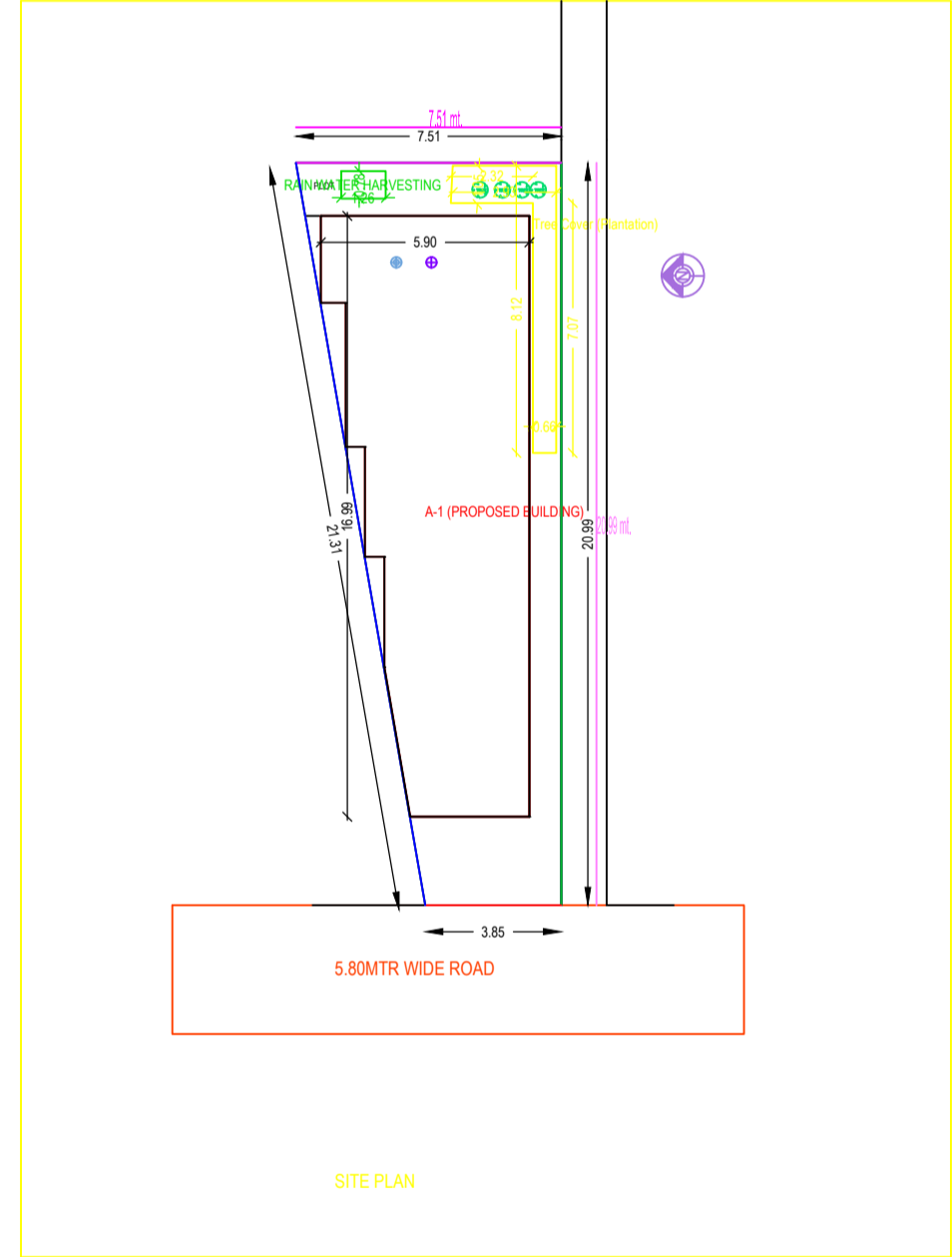
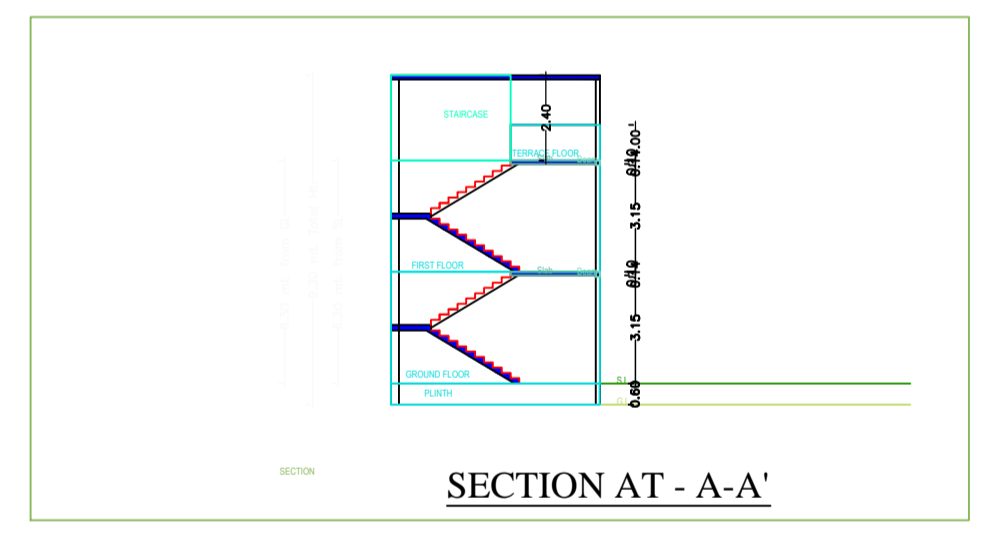
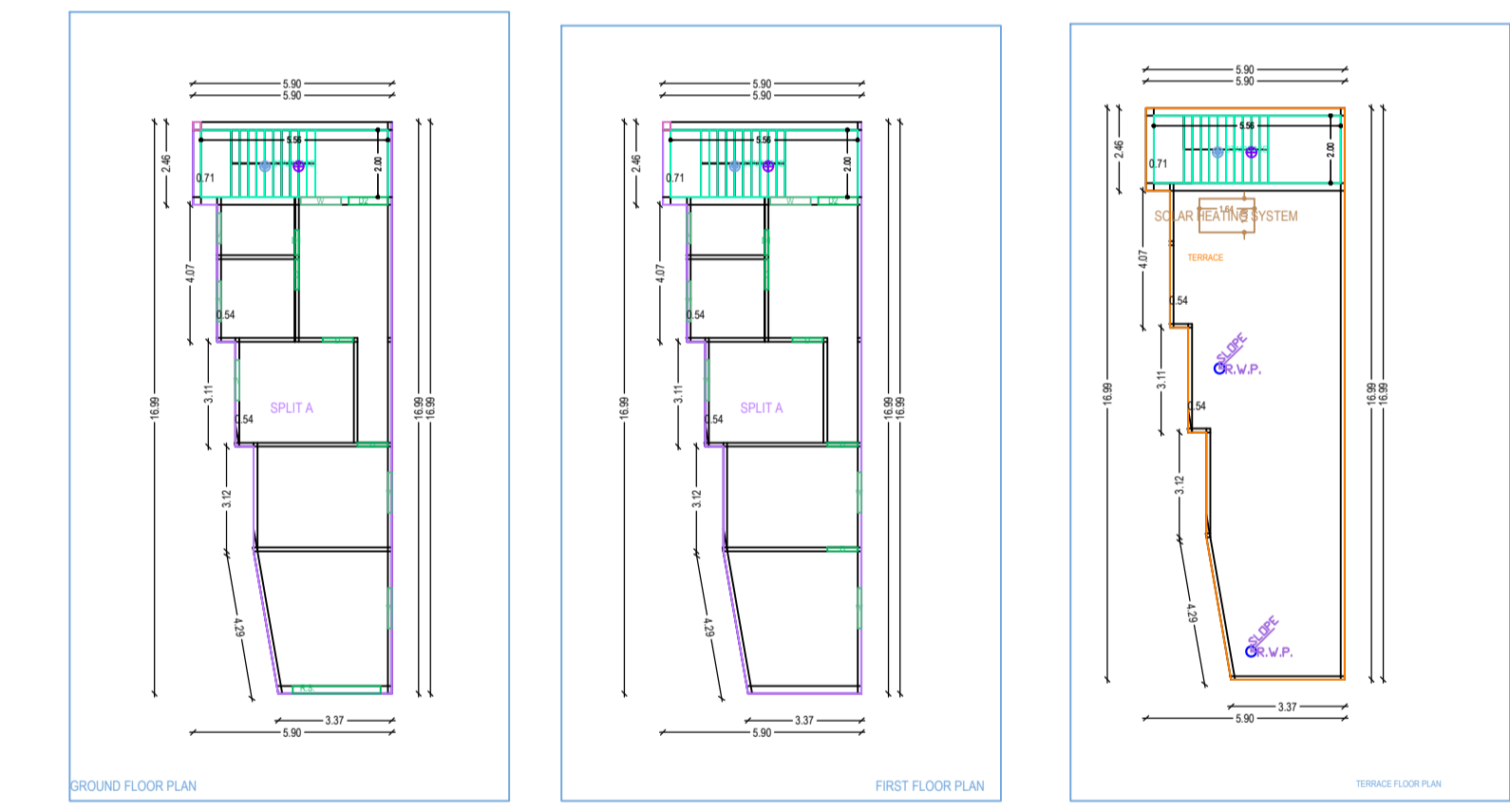
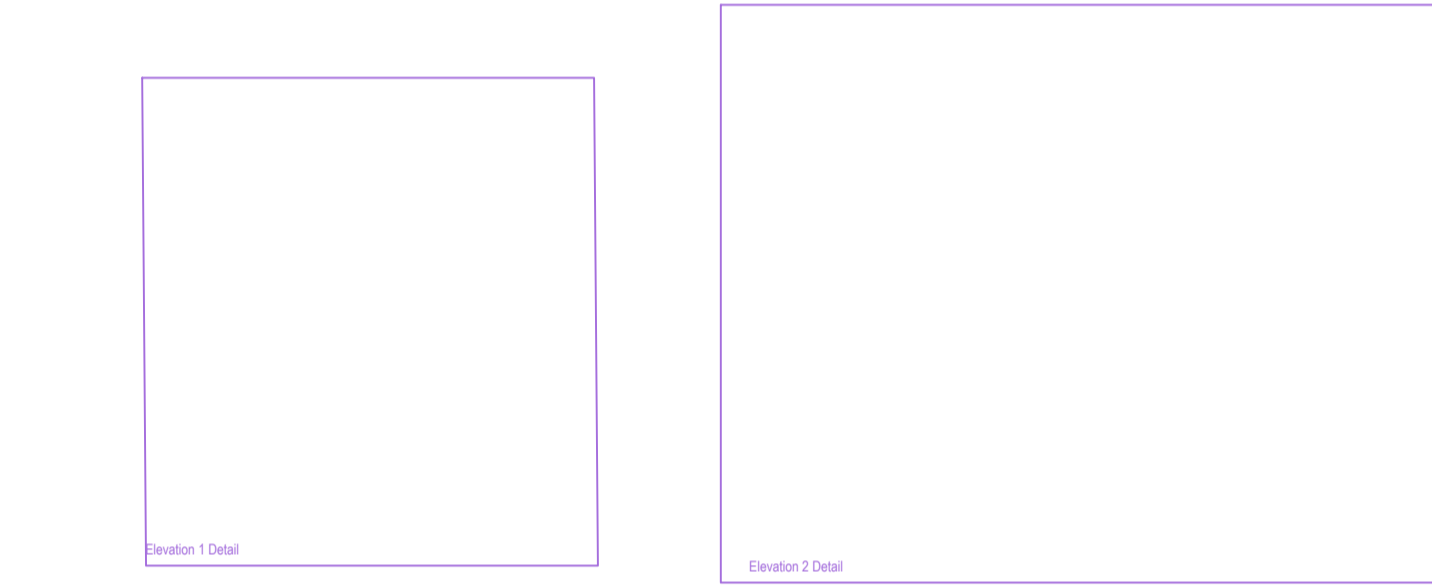
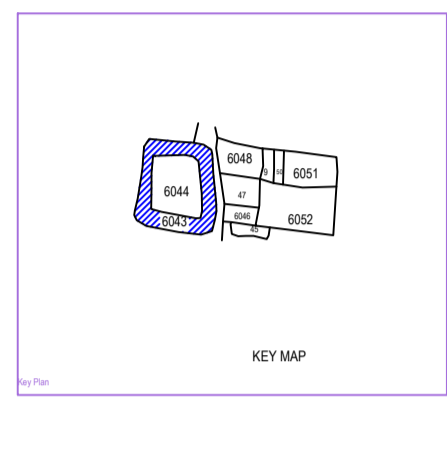
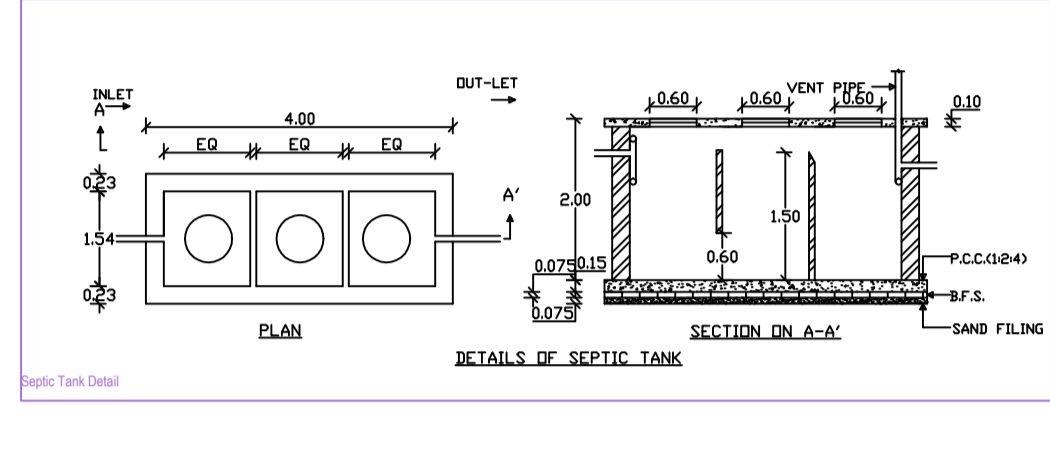
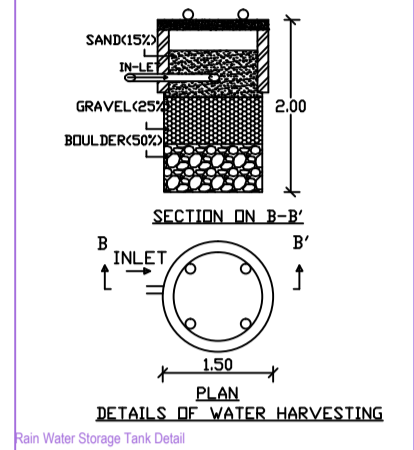
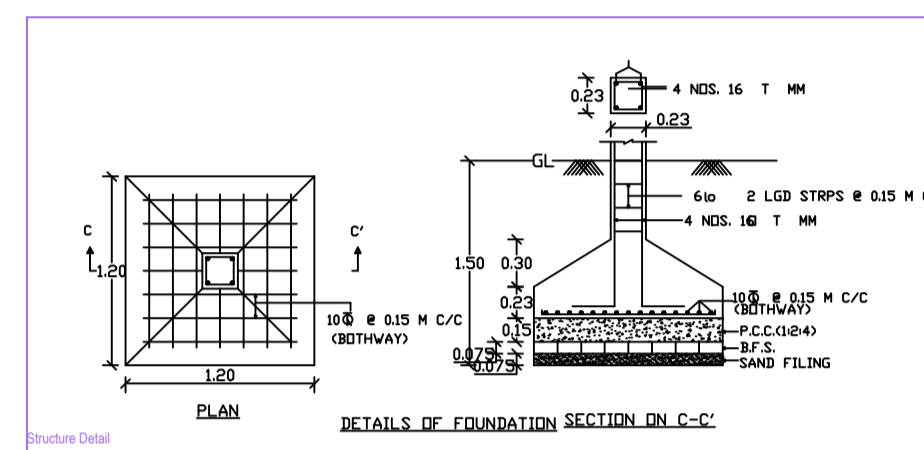

Room Name	Area (Sq.M)	Volume (Cu.M)	Remarks
Ground Floor	138.24	138.24	
First Floor	138.24	138.24	
Total	276.48	276.48	

Room Name	Area (Sq.M)	Volume (Cu.M)	Remarks
Ground Floor	138.24	138.24	
First Floor	138.24	138.24	
Total	276.48	276.48	

Room Name	Area (Sq.M)	Volume (Cu.M)	Remarks
Ground Floor	138.24	138.24	
First Floor	138.24	138.24	
Total	276.48	276.48	

Item	Description	Quantity	Unit	Rate	Amount
1	Excavation	100	Cu.M	100	10000
2	Concrete	100	Cu.M	100	10000
3	Reinforcement	100	Kg	100	10000
4	Formwork	100	Sq.M	100	10000
5	Labour	100	Day	100	10000
6	Transportation	100	Km	100	10000
7	Water	100	Cu.M	100	10000
8	Electricity	100	Kwh	100	10000
9	Material	100	Unit	100	10000
10	Other	100	Unit	100	10000
11	Profit	100	Unit	100	10000
12	Contingency	100	Unit	100	10000
13	Grand Total				130000