

Project Title - SMT. CHUNNI DEVI W/O- SRI VISHWAKARMA KUMAR ASHWATHAMA

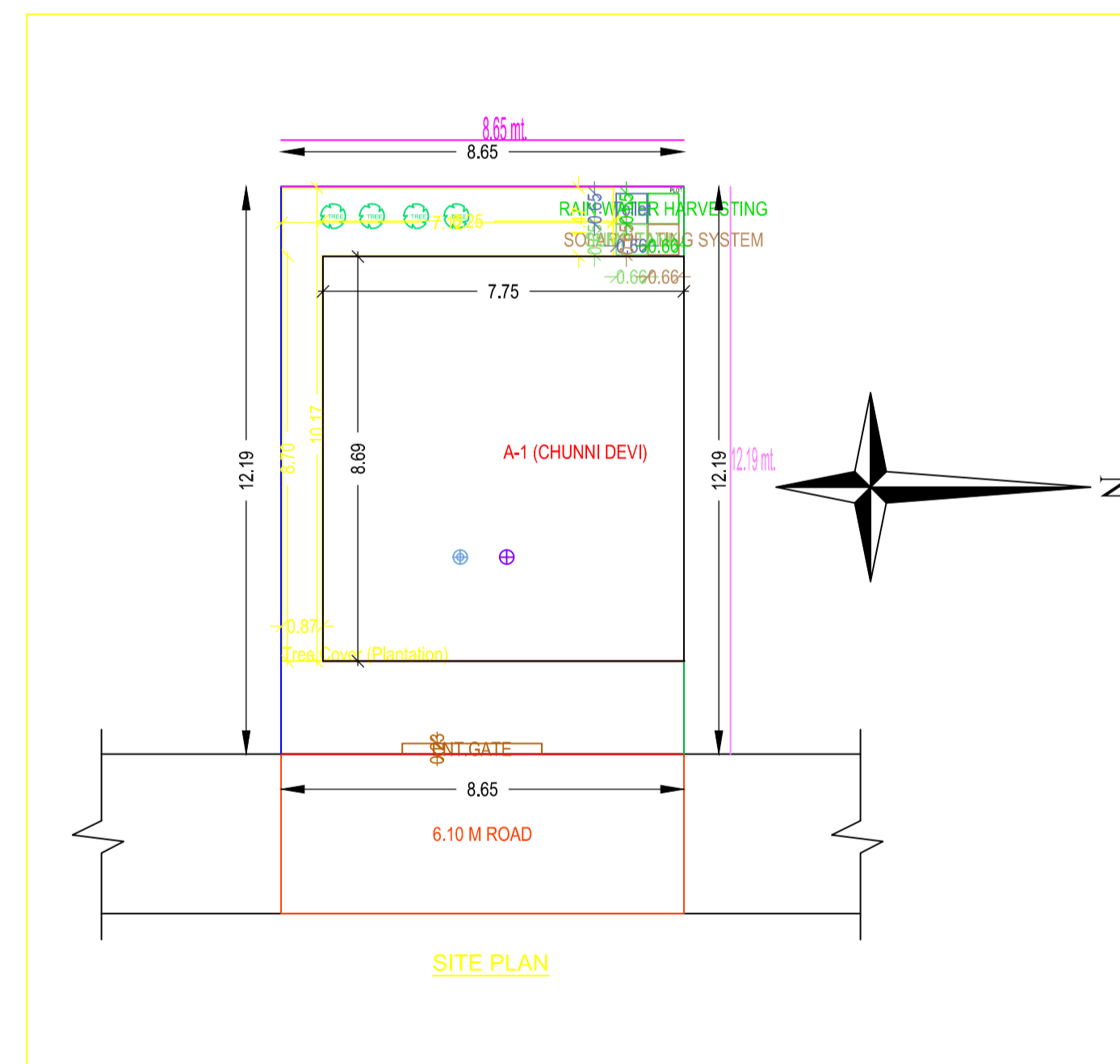
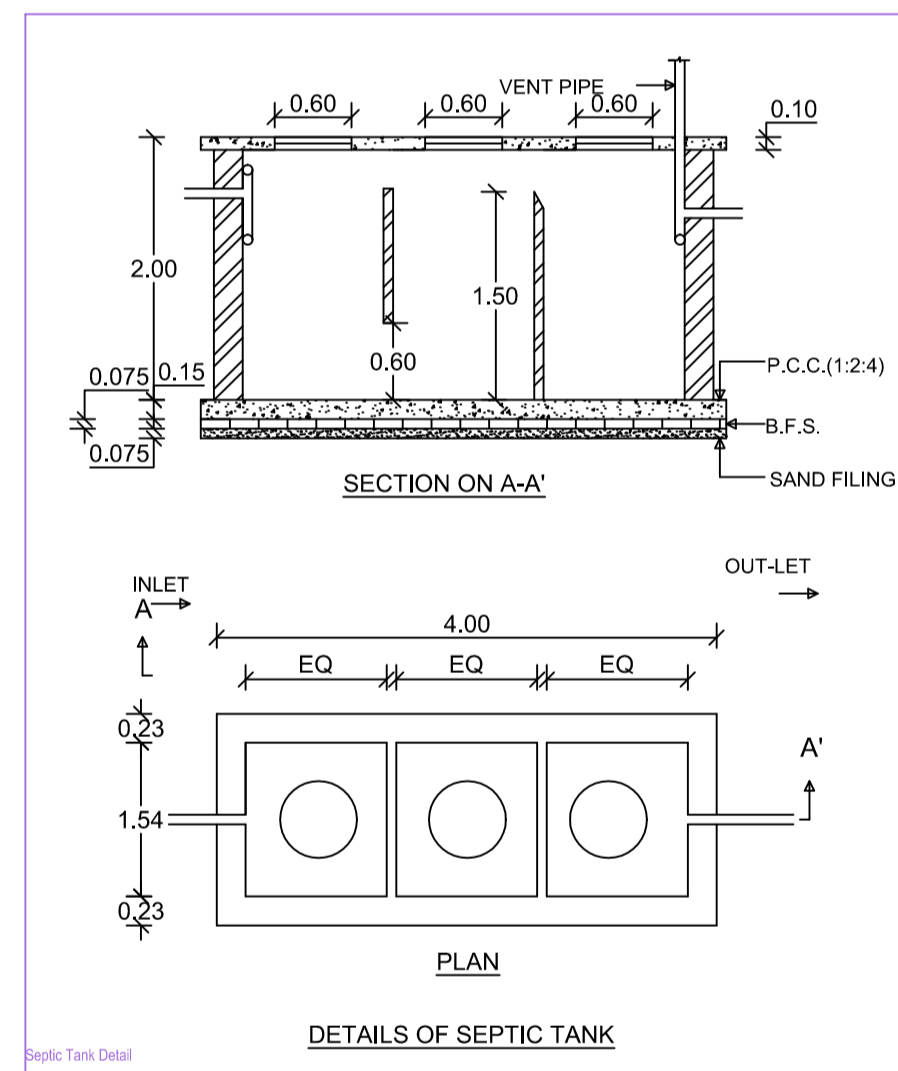
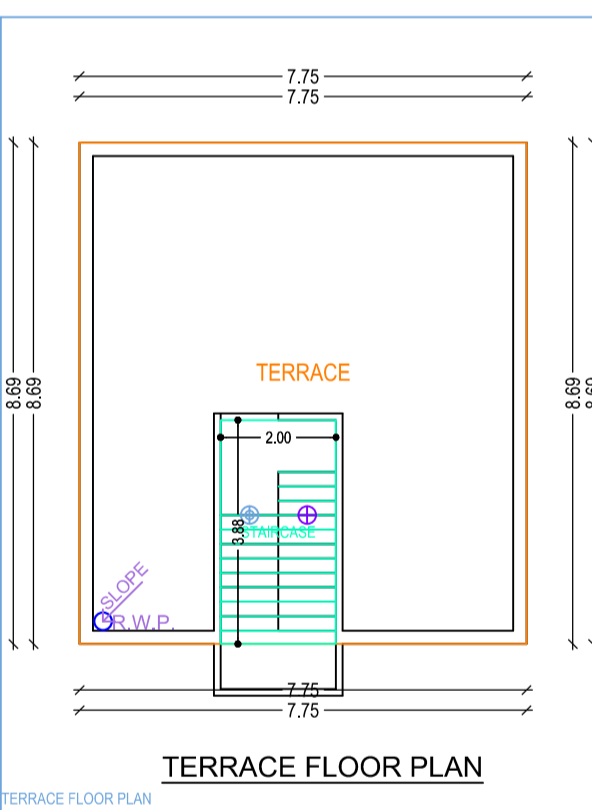
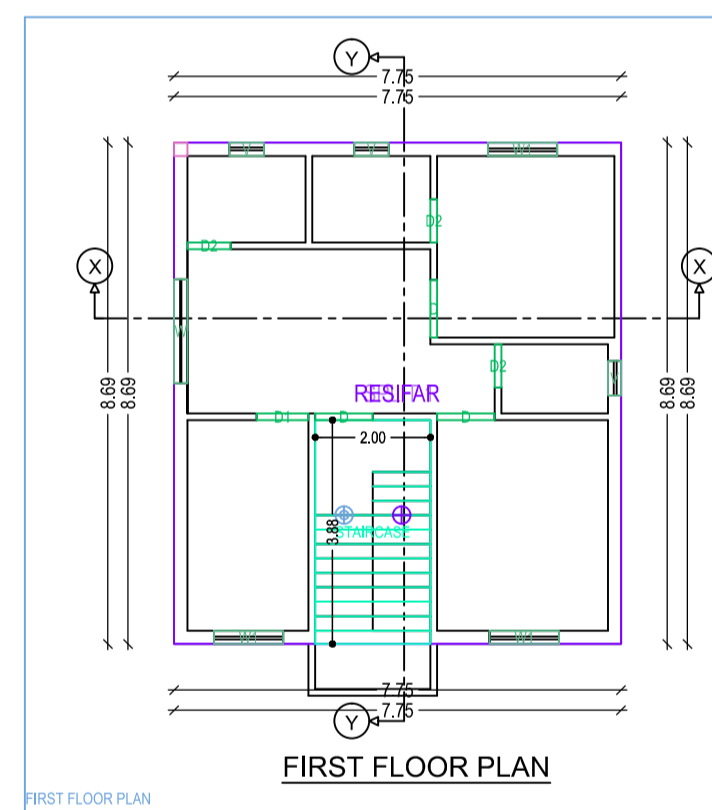
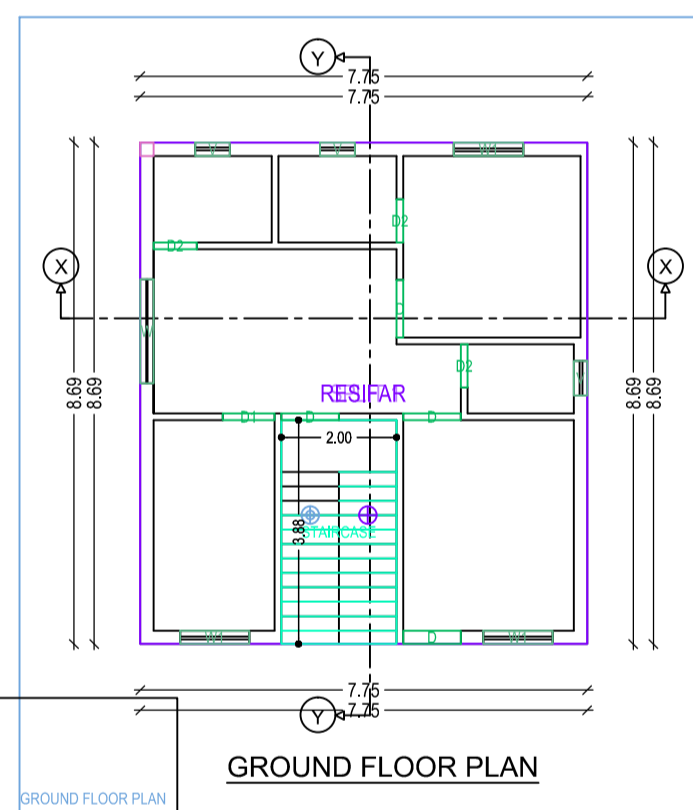
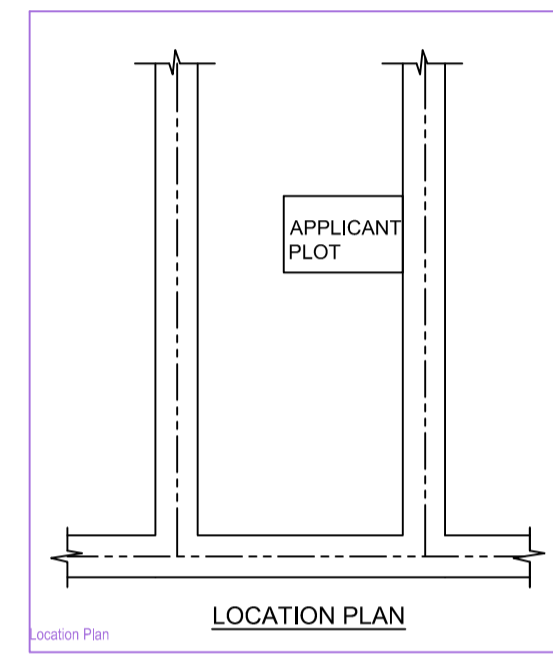
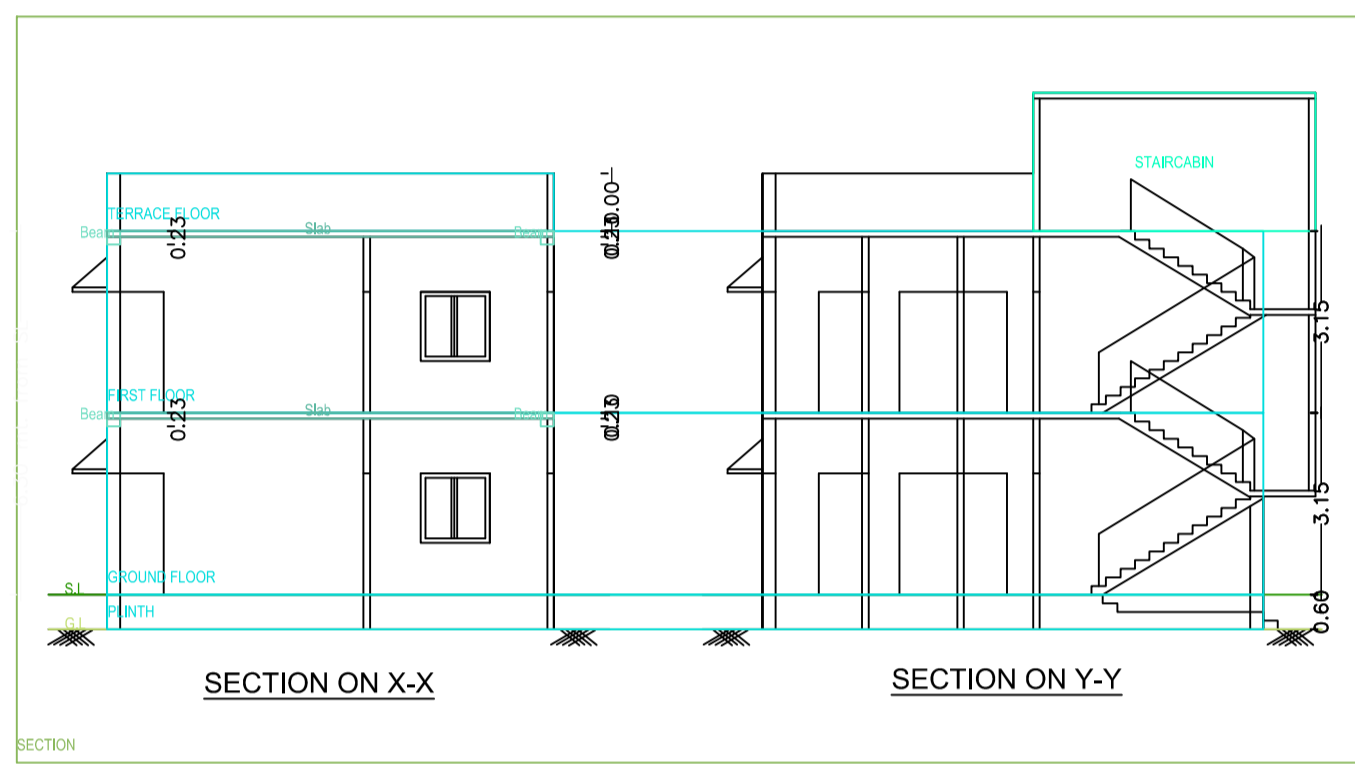
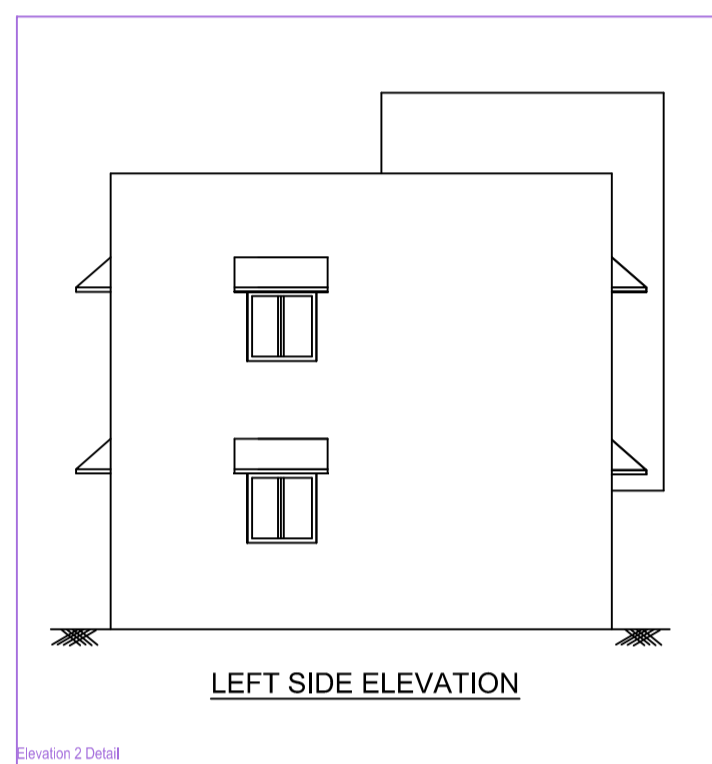
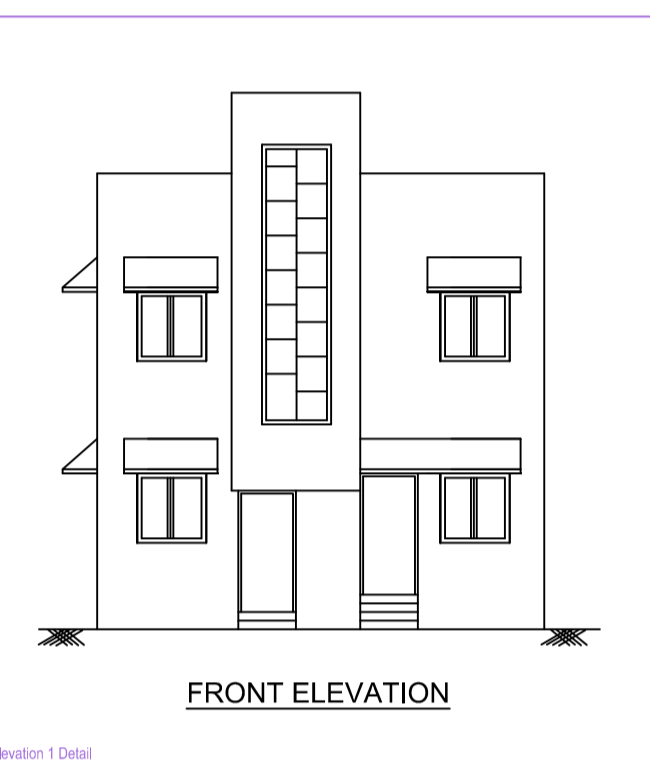
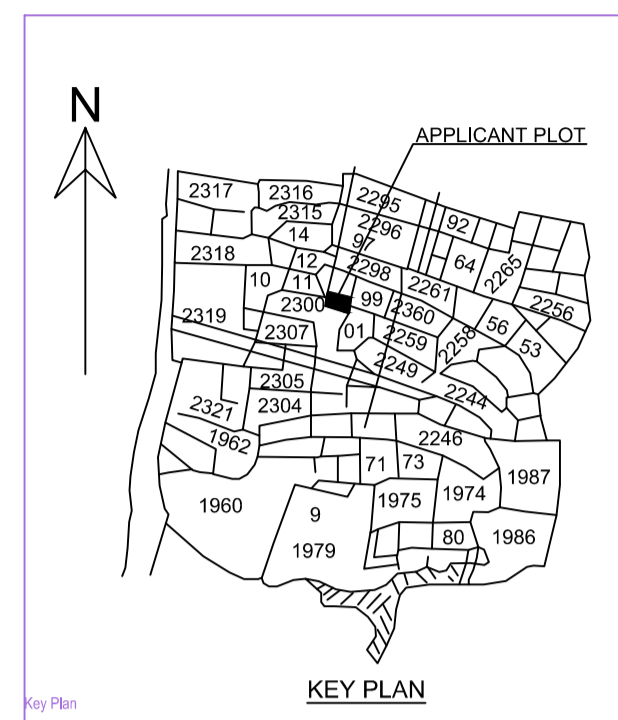
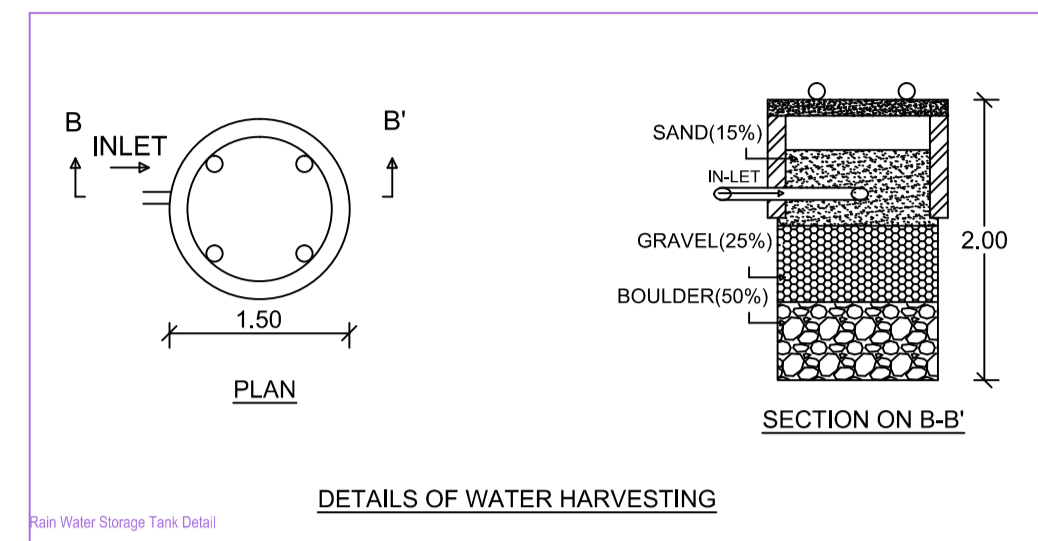
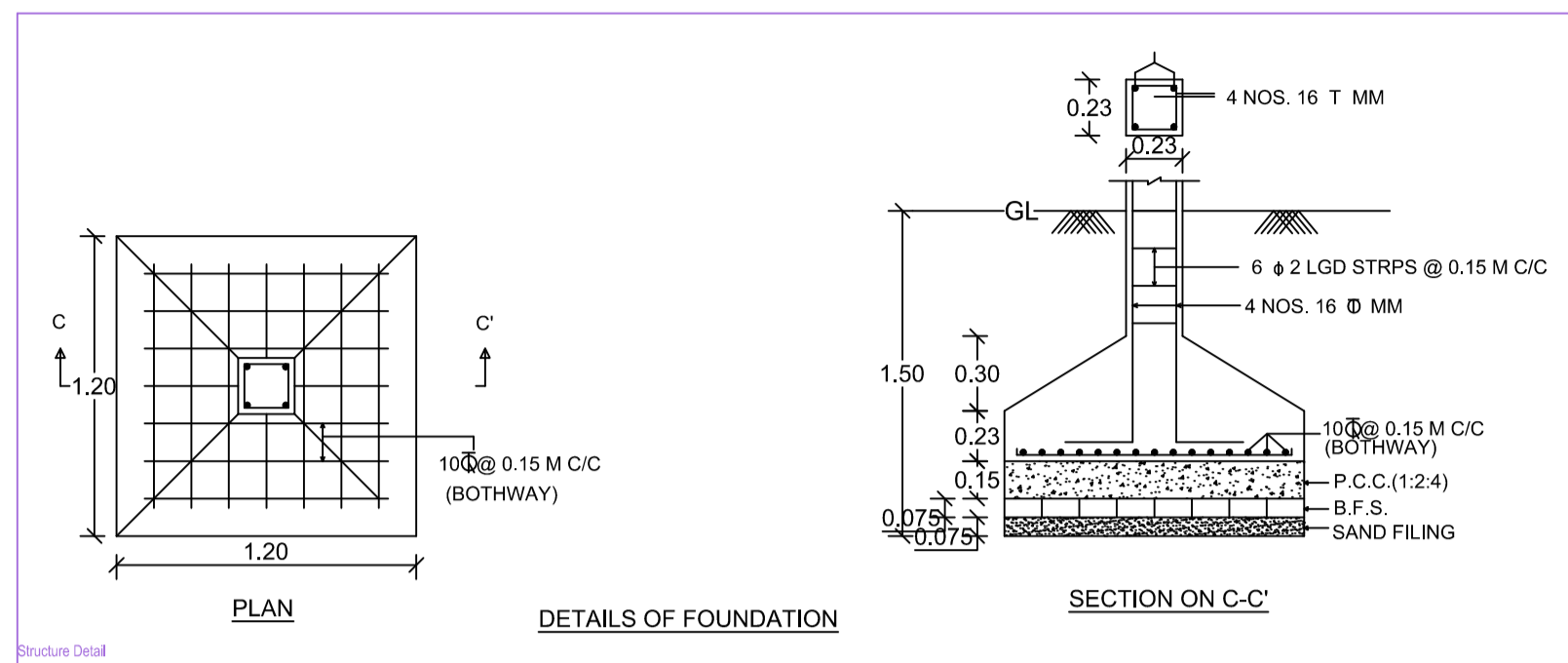

AREA STATEMENT CHAS MUNICIPAL CORPORATION	VERSION NO. 1.0.32
PROJECT DETAIL	VERSION DATE: 16/10/2020
Lineard No. -	Plot Use - Residential
Region - JHARKHAND URBAN LOCAL BODIES	Plot Sub Use - Bungalow/ Dwelling / Non Apartment
District - BOKARO	Land Use Zone - NA
Application Type - General Proposal	Abutting Road Width -
Project Type - Building Permission	Plot No. -
Nature of Development - New	Revenue Survey No/Survey No -
Location - Old Area	Thana No -
Site Location - NA	Holding No -
Village/Mauza Name -	Khasra No -
Ward No -	North -
Road/Street -	South -
	East -
	West -

AREA DETAILS:		SQ.MT.
AREA OF PLOT (Minimum)	(A)	105.44
Net Plot Area (Gross Plot Area - Deduction from Gross Plot Area)	(A-Deductions)	105.44
Deductions for Balance Plot Area (from Gross Plot Area)		
Total		17.99
COP Area		17.99
Total		87.45
Balance Plot Area (Net Plot Area - Recreational/Amenity space)	(A-Deductions)	87.45
Plot Area for Coverage (Net Plot Area)	(A-Deductions)	105.44
Plot Area for FSI (Net Plot Area + Road Widening Area)	(A-Deductions)	105.44
Accessory Area		0.43
COVERAGE CHECK		
Proposed Coverage Area (63.87 %)		67.35
Total Coverage Area (63.87 %)		67.35
FAR CHECK		
Proposed Area of FAR		134.70
Total Area of FAR		134.70
BUILT UP AREA CHECK		
Total Proposed BUILT UP Area		134.70
ARCHT ENGG/ SUPERVISOR (Regd)		OWNER
DEVELOPMENT AUTHORITY LOCAL BODY		

COLOR INDEX	
PLLOT BOUNDARY	Black
ABUTTING ROAD	Red
PROPOSED WORK (COVERAGE AREA)	Green
EXISTING (To be retained)	Blue
EXISTING (To be demolished)	Yellow

MARGIN DETAIL:						
Building / Wing Name	Road Name	Front Margin	Rear Margin	Side1 Margin	Side2 Margin	
A-1 (CHUNNI DEVI)	6.10 M ROAD	2.00	1.50	0.90	0.00	

FAR & Tenement Details (Table 4c-1)					
Building	No. of Same Bldg	Total Built Up Area (Sq.mt.)	Proposed FAR Res.	Total FAR Area (Sq.mt.)	Trent (No.)
A (CHUNNI DEVI)	1	134.70	134.70	134.70	01
Grand Total	1	134.70	134.70	134.70	01

Building :A (CHUNNI DEVI)					
Floor Name	Total Built Up Area (Sq.mt.)	Proposed FAR Area (Sq.mt.) Res.	Total FAR Area (Sq.mt.)	Trent (No.)	
Ground Floor...	67.35	67.35	67.35	01	
First Floor...	67.35	67.35	67.35	00	
Terrace Floor...	0.00	0.00	0.00	00	
Total	134.70	134.70	134.70	01	
Total Number of Same Buildings	1				
Total	134.70	134.70	134.70	01	

SCHEDULE OF JOINERY:					
BUILDING NAME	NAME	LENGTH	HEIGHT	NOS	
A (CHUNNI DEVI)	D2	0.75	2.10	06	
A (CHUNNI DEVI)	D1	0.90	2.10	02	
A (CHUNNI DEVI)	D	1.00	2.10	07	
Total	-	-	-	15	

SCHEDULE OF JOINERY:					
BUILDING NAME	NAME	LENGTH	HEIGHT	NOS	
A (CHUNNI DEVI)	V	0.60	1.00	06	
A (CHUNNI DEVI)	W1	1.20	1.20	06	
A (CHUNNI DEVI)	W	1.80	1.20	02	
Total	-	-	-	14	

UnitBUA Table for Building :A (CHUNNI DEVI)						
FLOOR	Name	UnitBUA Type	UnitBUA Area	Carpet Area	No. of Rooms	No. of Tenement
GROUND FLOOR PLAN	SPLIT 1	FLAT	134.70	134.59	8	1
Total	-	-	134.70	134.59	16	1