

Project Title - SMT SITA DEVI

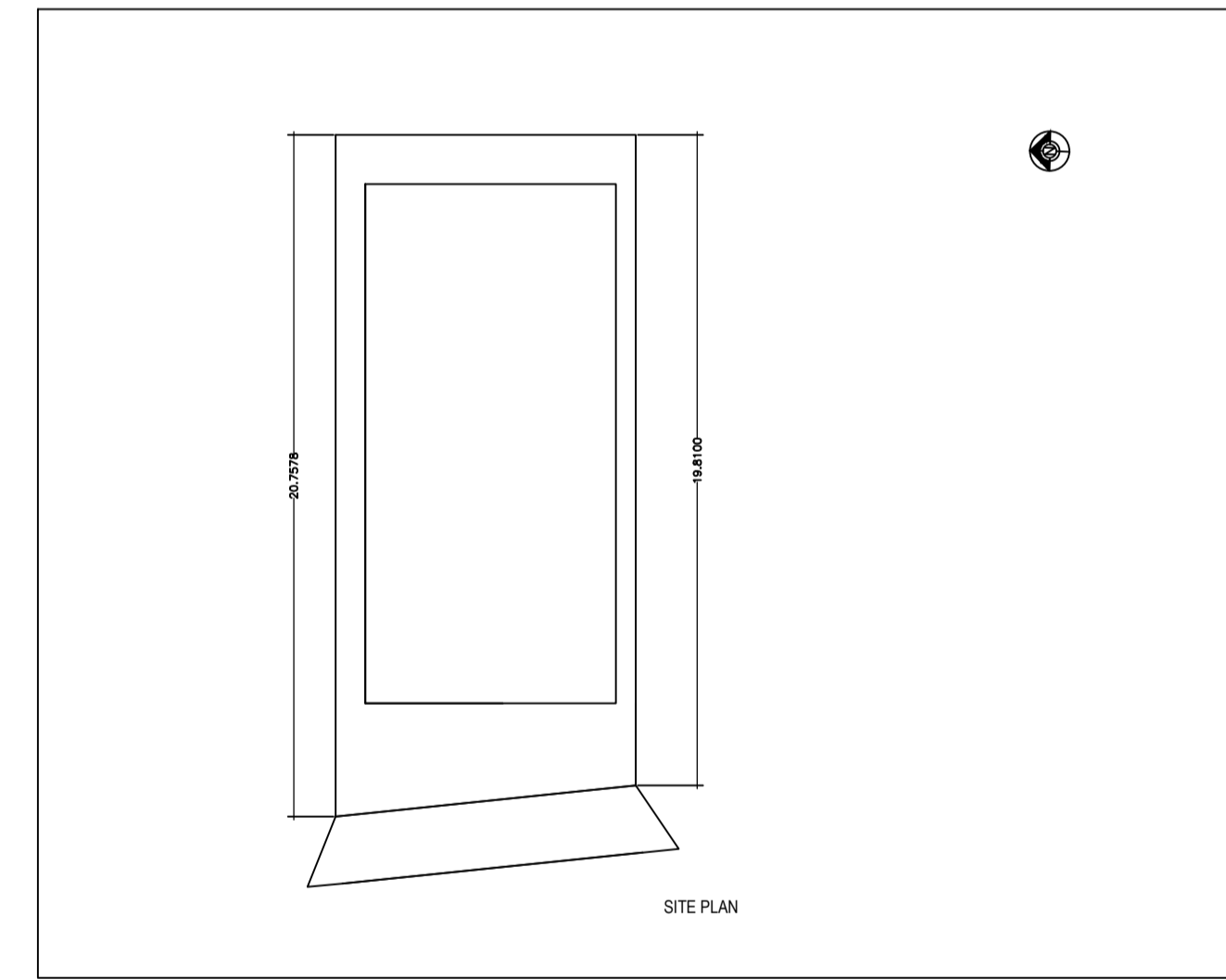
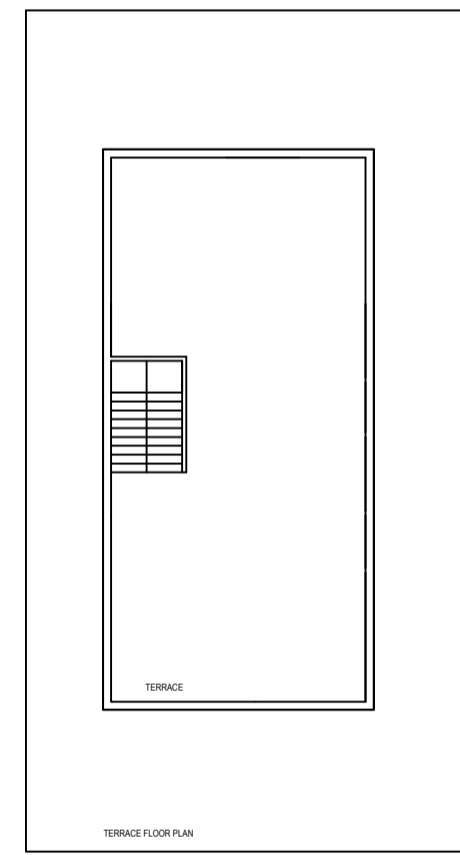
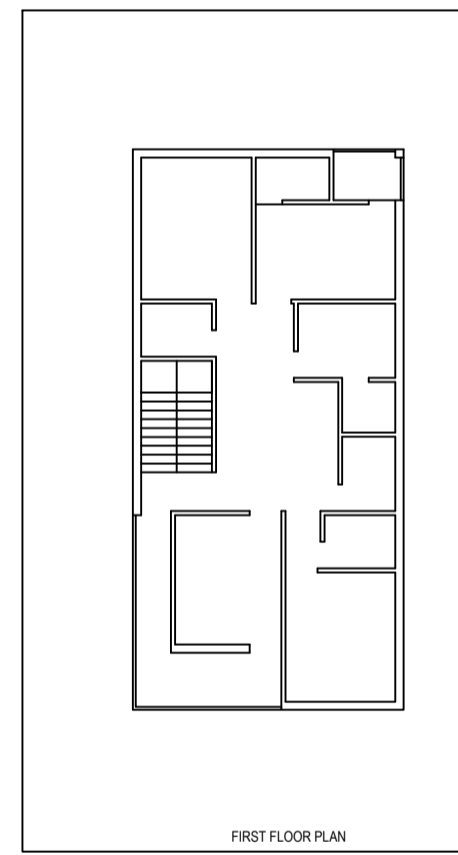
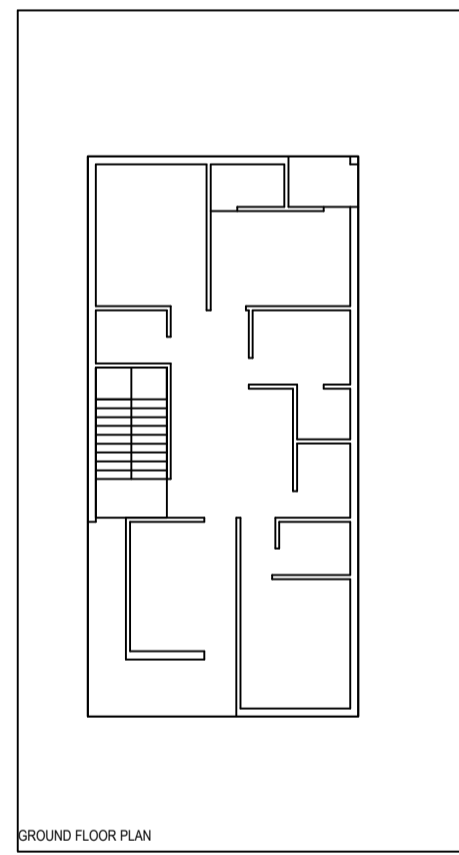
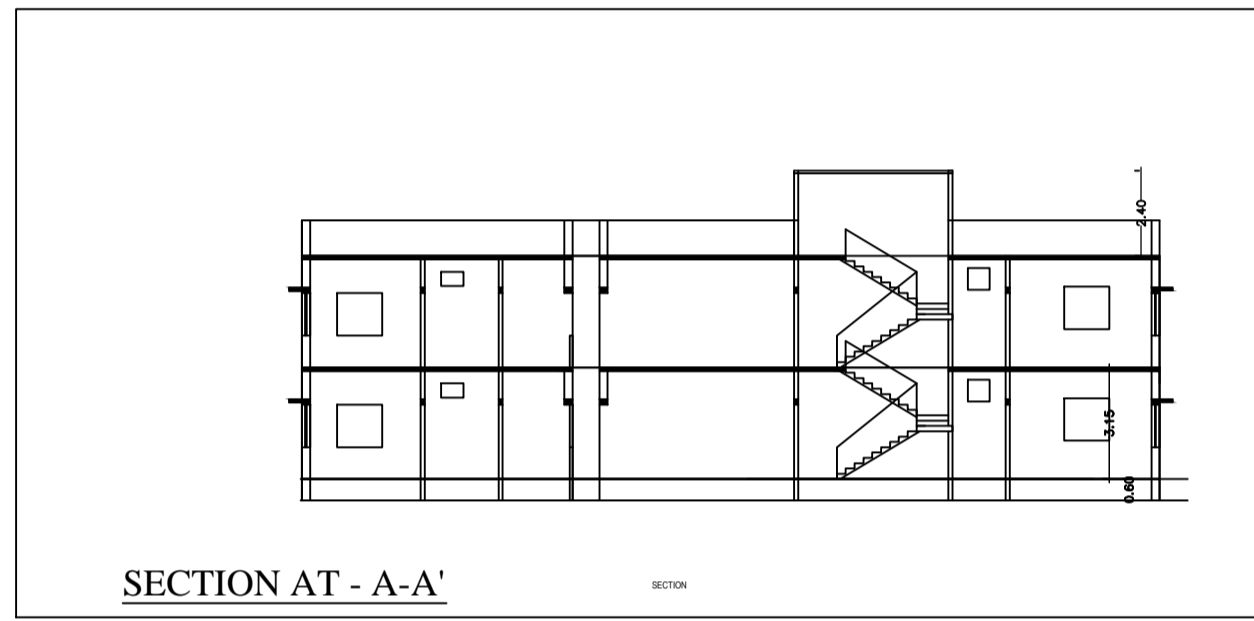
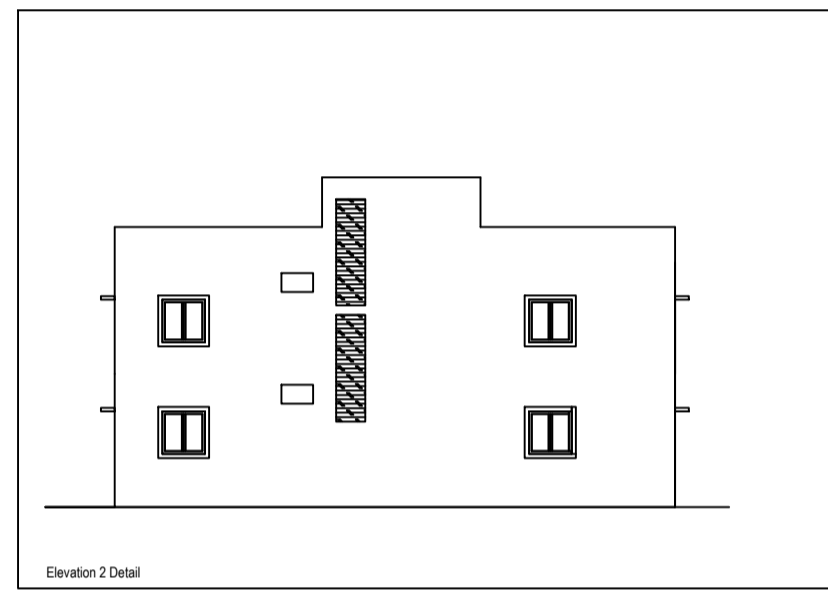
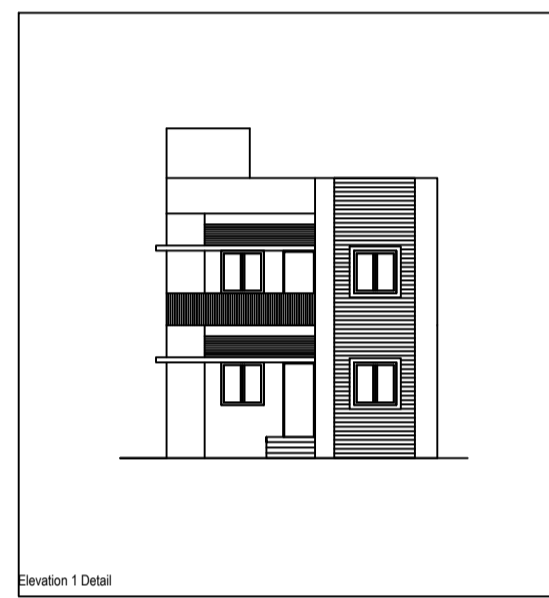
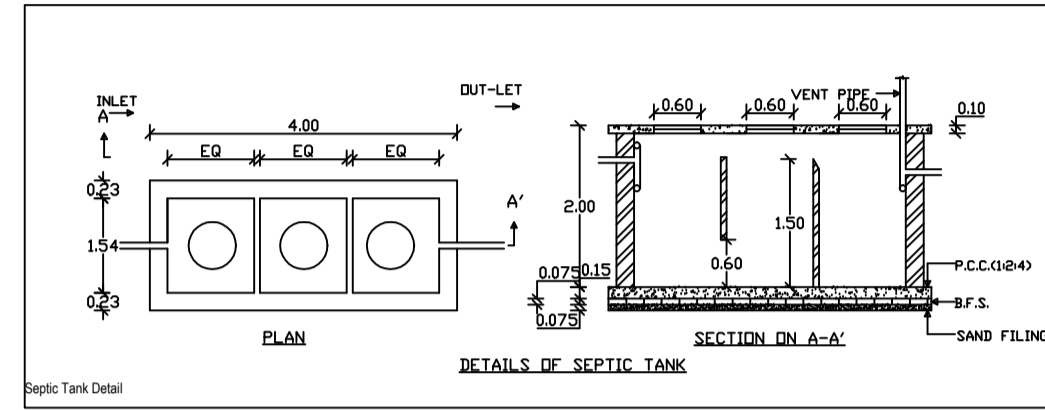
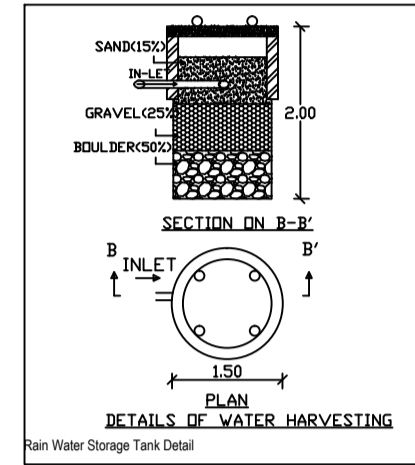
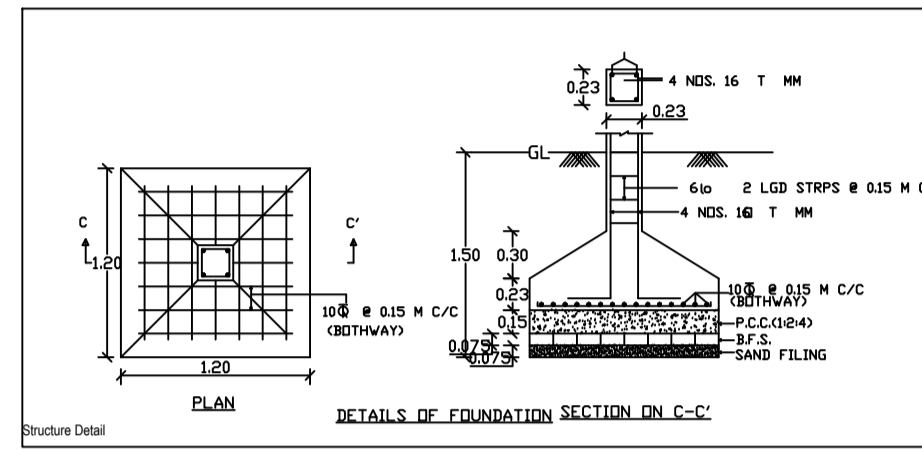

DESCRIPTION	SECTION No. / E.D.
FOUNDATION	SECTION 1.1.1
WATER HARVESTING	SECTION 1.1.2
SEPTIC TANK	SECTION 1.1.3
STRUCTURE	SECTION 1.1.4
ROOFING	SECTION 1.1.5
MECHANICAL	SECTION 1.1.6
ELECTRICAL	SECTION 1.1.7
PLUMBING	SECTION 1.1.8
PAINTING	SECTION 1.1.9
LANDSCAPING	SECTION 1.1.10
ENVIRONMENTAL	SECTION 1.1.11
LOCAL BODY	SECTION 1.1.12

ITEM NO.	DESCRIPTION	QTY	UNIT	ESTD.
1	FOUNDATION	1	SQ. M.	100.00
2	WATER HARVESTING	1	SQ. M.	150.00
3	SEPTIC TANK	1	SQ. M.	120.00
4	STRUCTURE	1	SQ. M.	200.00
5	ROOFING	1	SQ. M.	80.00
6	MECHANICAL	1	SQ. M.	100.00
7	ELECTRICAL	1	SQ. M.	120.00
8	PLUMBING	1	SQ. M.	100.00
9	PAINTING	1	SQ. M.	100.00
10	LANDSCAPING	1	SQ. M.	100.00
11	ENVIRONMENTAL	1	SQ. M.	100.00
12	LOCAL BODY	1	SQ. M.	100.00

ITEM NO.	DESCRIPTION	QTY	UNIT	ESTD.
1	FOUNDATION	1	SQ. M.	100.00
2	WATER HARVESTING	1	SQ. M.	150.00
3	SEPTIC TANK	1	SQ. M.	120.00
4	STRUCTURE	1	SQ. M.	200.00
5	ROOFING	1	SQ. M.	80.00
6	MECHANICAL	1	SQ. M.	100.00
7	ELECTRICAL	1	SQ. M.	120.00
8	PLUMBING	1	SQ. M.	100.00
9	PAINTING	1	SQ. M.	100.00
10	LANDSCAPING	1	SQ. M.	100.00
11	ENVIRONMENTAL	1	SQ. M.	100.00
12	LOCAL BODY	1	SQ. M.	100.00

ITEM NO.	DESCRIPTION	QTY	UNIT	ESTD.
1	FOUNDATION	1	SQ. M.	100.00
2	WATER HARVESTING	1	SQ. M.	150.00
3	SEPTIC TANK	1	SQ. M.	120.00
4	STRUCTURE	1	SQ. M.	200.00
5	ROOFING	1	SQ. M.	80.00
6	MECHANICAL	1	SQ. M.	100.00
7	ELECTRICAL	1	SQ. M.	120.00
8	PLUMBING	1	SQ. M.	100.00
9	PAINTING	1	SQ. M.	100.00
10	LANDSCAPING	1	SQ. M.	100.00
11	ENVIRONMENTAL	1	SQ. M.	100.00
12	LOCAL BODY	1	SQ. M.	100.00

ITEM NO.	DESCRIPTION	QTY	UNIT	ESTD.
1	FOUNDATION	1	SQ. M.	100.00
2	WATER HARVESTING	1	SQ. M.	150.00
3	SEPTIC TANK	1	SQ. M.	120.00
4	STRUCTURE	1	SQ. M.	200.00
5	ROOFING	1	SQ. M.	80.00
6	MECHANICAL	1	SQ. M.	100.00
7	ELECTRICAL	1	SQ. M.	120.00
8	PLUMBING	1	SQ. M.	100.00
9	PAINTING	1	SQ. M.	100.00
10	LANDSCAPING	1	SQ. M.	100.00
11	ENVIRONMENTAL	1	SQ. M.	100.00
12	LOCAL BODY	1	SQ. M.	100.00

ITEM NO.	DESCRIPTION	QTY	UNIT	ESTD.
1	FOUNDATION	1	SQ. M.	100.00
2	WATER HARVESTING	1	SQ. M.	150.00
3	SEPTIC TANK	1	SQ. M.	120.00
4	STRUCTURE	1	SQ. M.	200.00
5	ROOFING	1	SQ. M.	80.00
6	MECHANICAL	1	SQ. M.	100.00
7	ELECTRICAL	1	SQ. M.	120.00
8	PLUMBING	1	SQ. M.	100.00
9	PAINTING	1	SQ. M.	100.00
10	LANDSCAPING	1	SQ. M.	100.00
11	ENVIRONMENTAL	1	SQ. M.	100.00
12	LOCAL BODY	1	SQ. M.	100.00

Floor Name	Total Built-up Area (Sq.M)	Occupied Area (Sq.M)	Proposed FSI Area (Sq.M)	Total FSI Area (Sq.M)	Floor No.
Ground Floor	100.00	80.00	100.00	100.00	01
First Floor	100.00	80.00	100.00	100.00	02
Terrace Floor	100.00	80.00	100.00	100.00	03
Roof	100.00	80.00	100.00	100.00	04
Total	400.00	320.00	400.00	400.00	01

FLOOR NAME	NO.	AREA (SQ.M)	NO. OF STAIRS
FLOOR 01	01	100.00	01
FLOOR 02	02	100.00	01
FLOOR 03	03	100.00	01
FLOOR 04	04	100.00	01
TOTAL		400.00	04

FLOOR NAME	NO.	AREA (SQ.M)	NO. OF STAIRS
FLOOR 01	01	100.00	01
FLOOR 02	02	100.00	01
FLOOR 03	03	100.00	01
FLOOR 04	04	100.00	01
TOTAL		400.00	04

FLOOR	NO.	CONCRETE PART	CEMENT AREA	NO. OF STAIRS	NO. OF STAIRS
FLOOR 01	01	100.00	100.00	01	01
FLOOR 02	02	100.00	100.00	01	01
FLOOR 03	03	100.00	100.00	01	01
FLOOR 04	04	100.00	100.00	01	01
TOTAL		400.00	400.00	04	04