

Proposal Basic Information

Proposal File No.	CMC/BP/0218/W07/2022
Owner Name	SMT. KRISHNA DEY
Khata No	656
Plot No	3845
Village Name	Chas
Use	Residential
SubUse	Bungalow/ Dwelling / Non Apartment

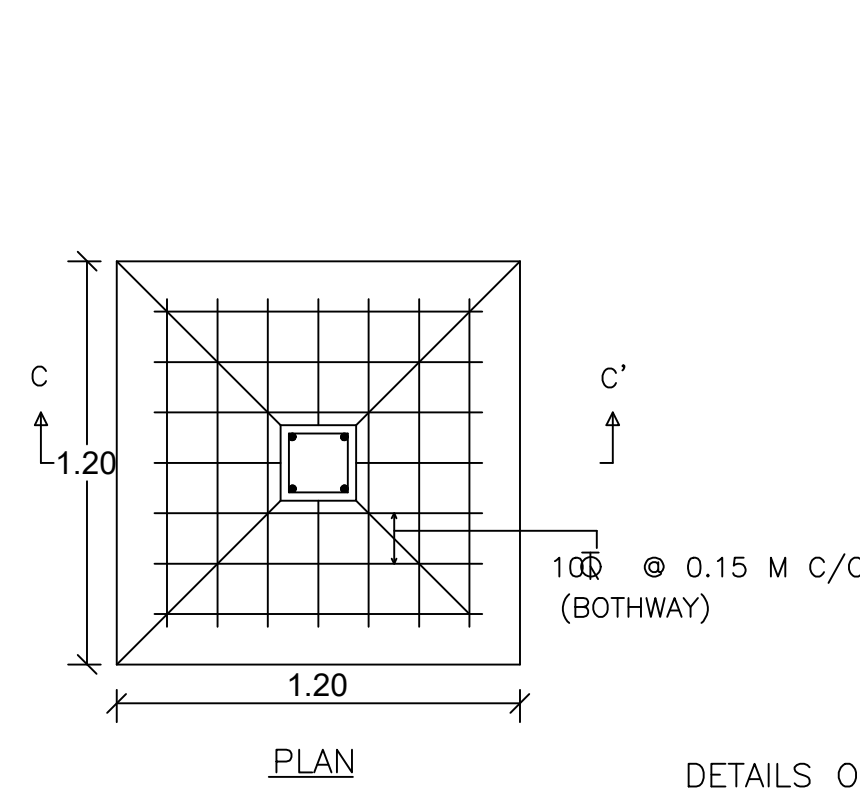

DETAILS OF FOUNDATION

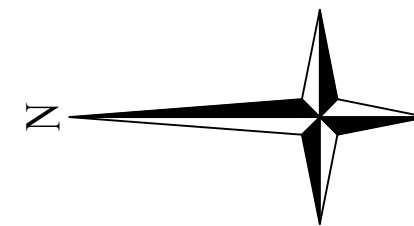
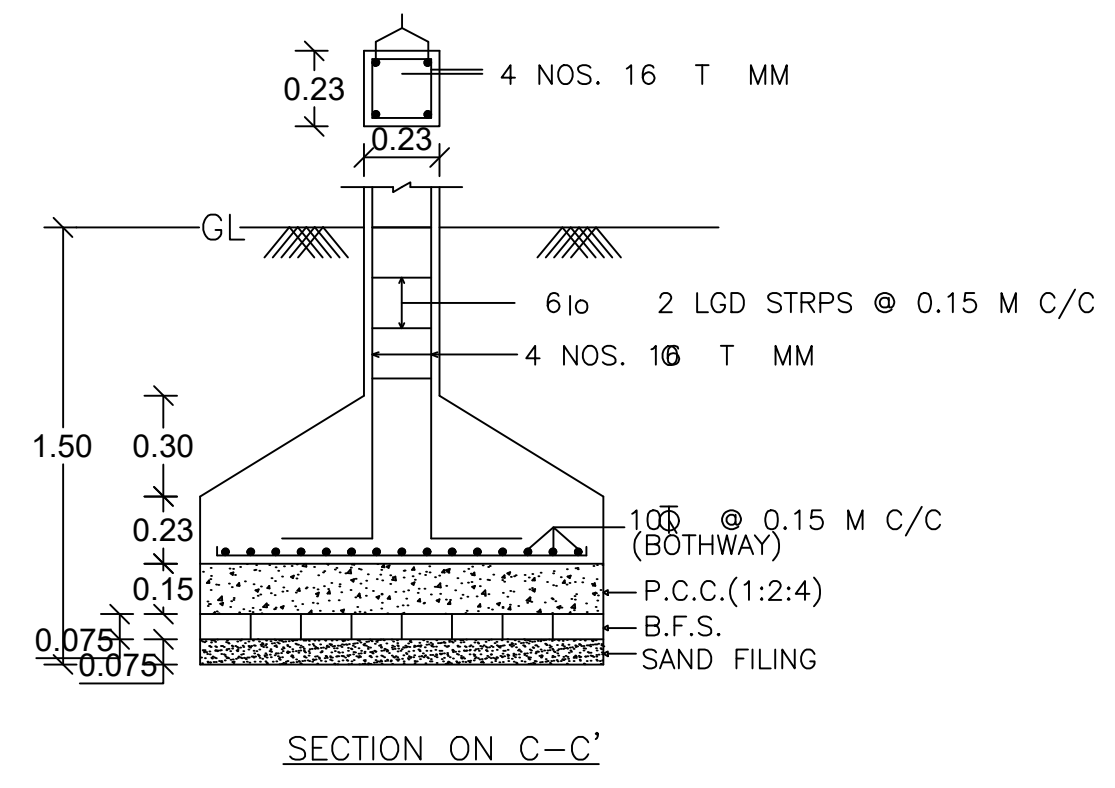

SECTION ON C-C'

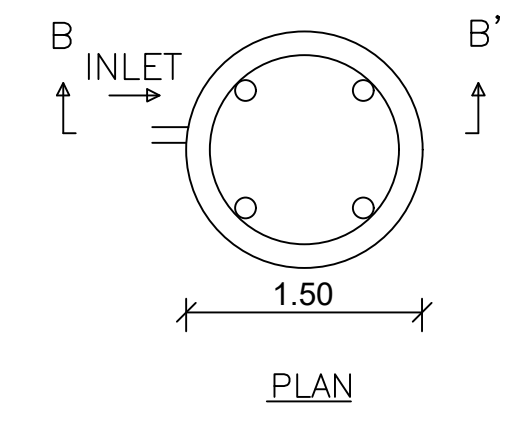

DETAILS OF WATER HARVESTING

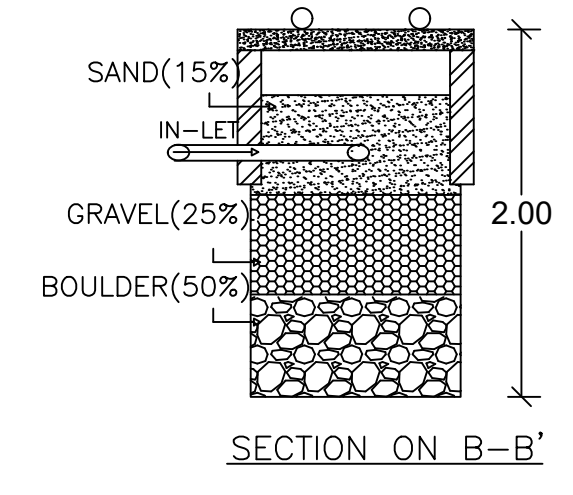

SECTION ON B-B'

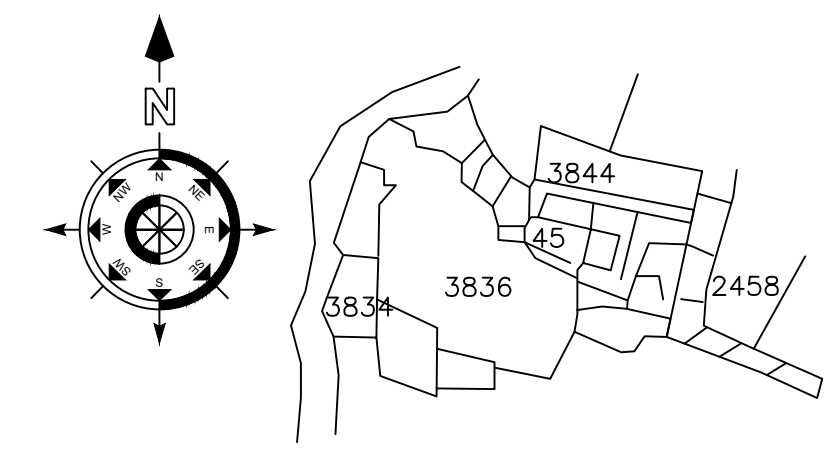

KEY PLAN

AREA STATEMENT CHAS MUNICIPAL CORPORATION	VERSION NO.: 1.0.64	SQ.MT.
PROJECT DETAIL:	VERSION DATE: 16/10/2020	
Region: JHARKHAND URBAN LOCAL BODIES	Plot Use: Residential	
District: BOKARO	Plot SubUse: Bungalow/ Dwelling / Non Apartment	
Authority: CHAS MUNICIPAL CORPORATION	PlotNearbyReligiousStructure: NA	
Inward_No: CMC/BP/0218/W07/2022	PlotSubPlot No: 3845	
Application Type: General Proposal	North: Plot No. - MUNNI DEVI	
Project Type: Building Permission	South: Plot No. - CHANDAN KUMAR SHARMA	
Nature of Development: New	East: Plot No. - 3841	
Location of Development Area: Old Area	West: Road Width - 4.57 M ROAD	
AREA DETAILS:		
AREA OF PLOT (Minimum)	(A)	79.70
NET AREA OF PLOT(Gross Plot Area - Deduction from Gross Plot area)	(A-Deductions)	79.70
Deduction for Balance Plot Area(from Gross Plot Area)		
Common Plot		11.08
Total		11.08
BALANCE AREA OF PLOT(Net Plot Area - Recreational/Amenity space)	(A-Deductions)	68.63
PLOT AREA FOR COVERAGE(Net Plot Area)	(A-Deductions)	79.70
Plot Area for FAR (Net Plot Area + Road Widening Area)	(A-Deductions)	79.70
COVERAGE CHECK		
Permissible Coverage area (70.00 %)		55.79
Proposed Coverage Area (65.66 %)		52.33
Total Prop. Coverage Area (65.66 %)		52.33
Balance coverage area (4.34 %)		3.46
FAR CHECK		
Perm. FAR Area (1.50)		119.55
Total Perm. FAR area		119.55
Residential FAR		104.66
Proposed FAR Area		104.66
Total Proposed FAR Area		104.66
Consumed FAR (Factor)		1.31
Balance FAR Area		14.89
BUILT UP AREA CHECK		
Total Proposed BuiltUp Area		104.66
ARCHITECT (Regd)		RAVI KUMAR
ENGINEER (Regd)		
SUPERVISOR (Regd)		
OWNER (Regd)		SMT. KRISHNA DEY
DEVELOPMENT AUTHORITY LOCAL BODY		

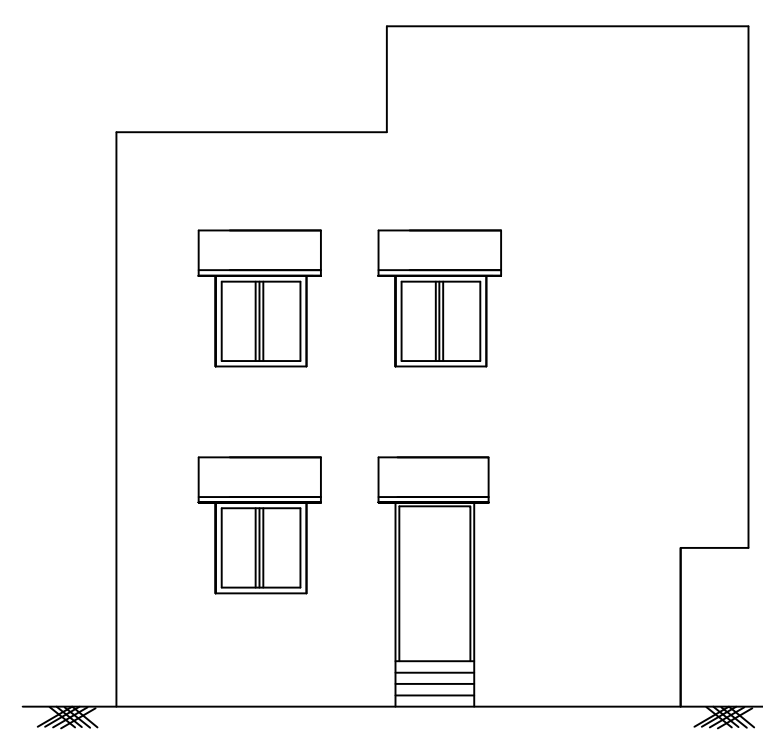

FRONT ELEVATION

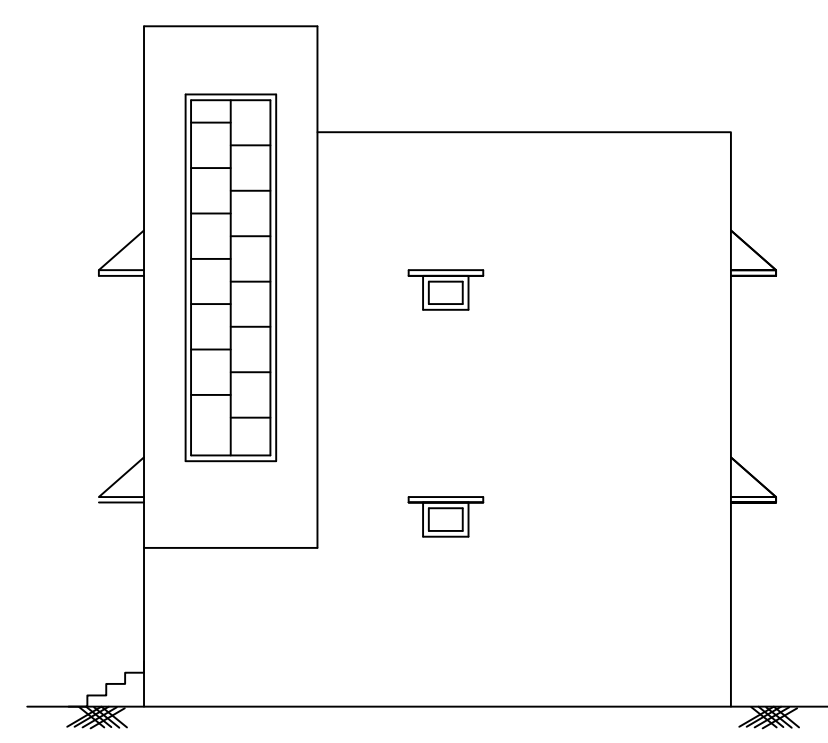

RIGHT SIDE ELEVATION

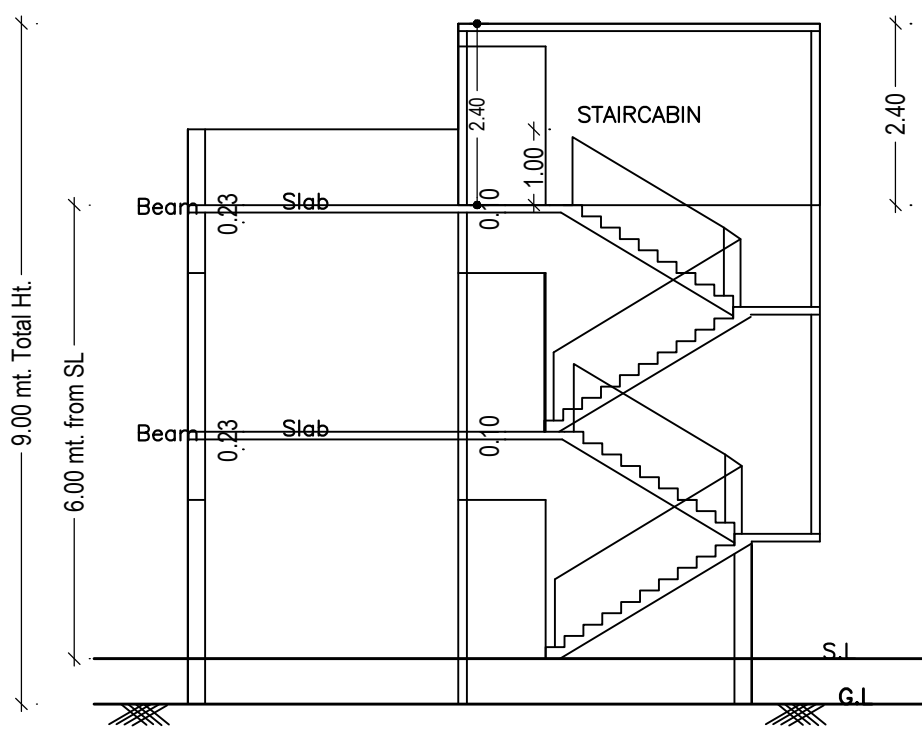

SECTION ON Y-Y

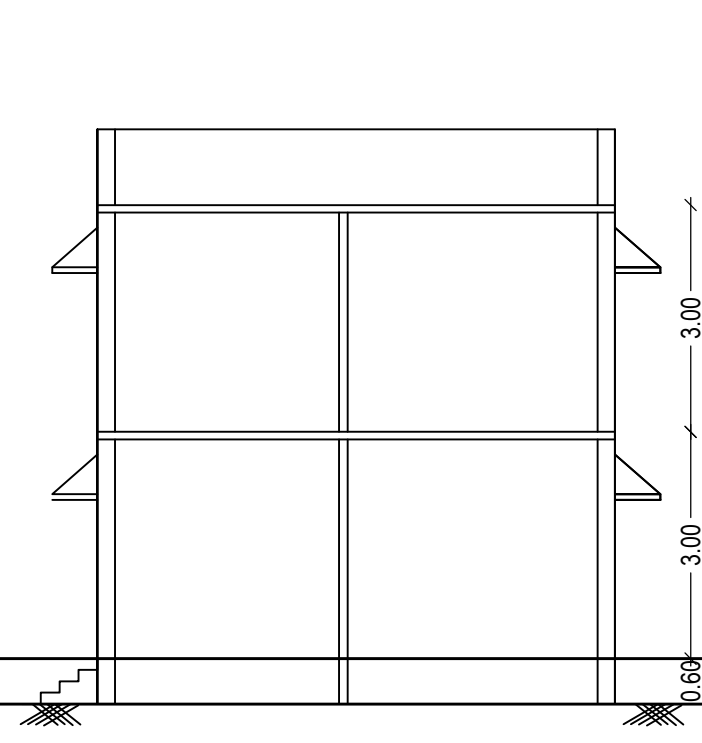

SECTION ON Y-Y

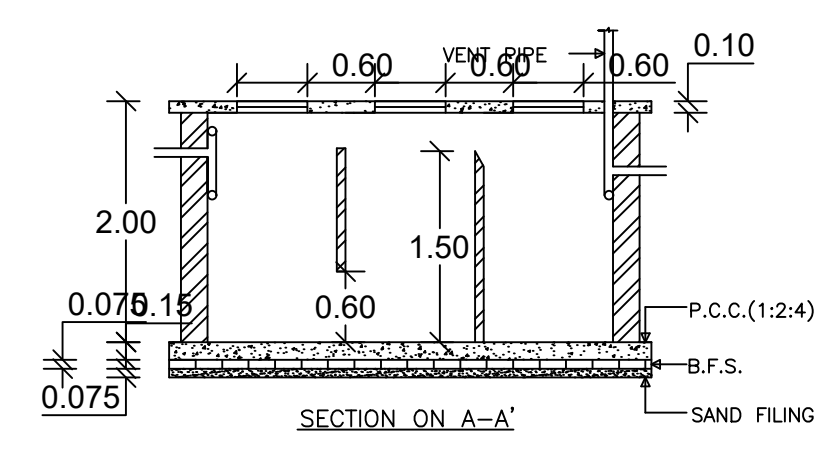

SECTION ON A-A'

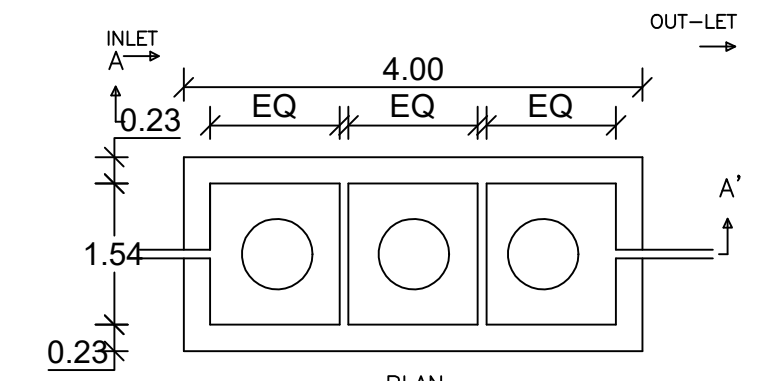

PLAN

DETAILS OF SEPTIC TANK

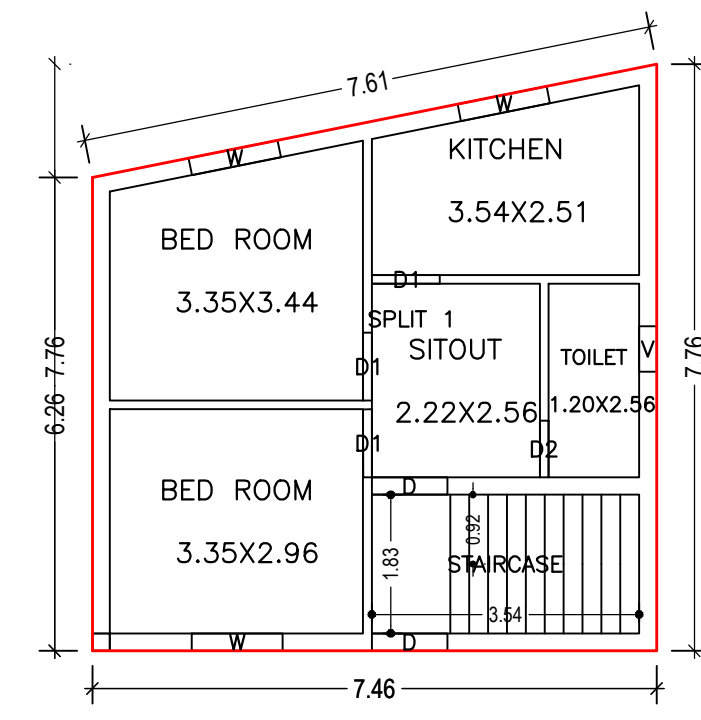

GROUND FLOOR PLAN (Proposed) (SCALE 1:100)

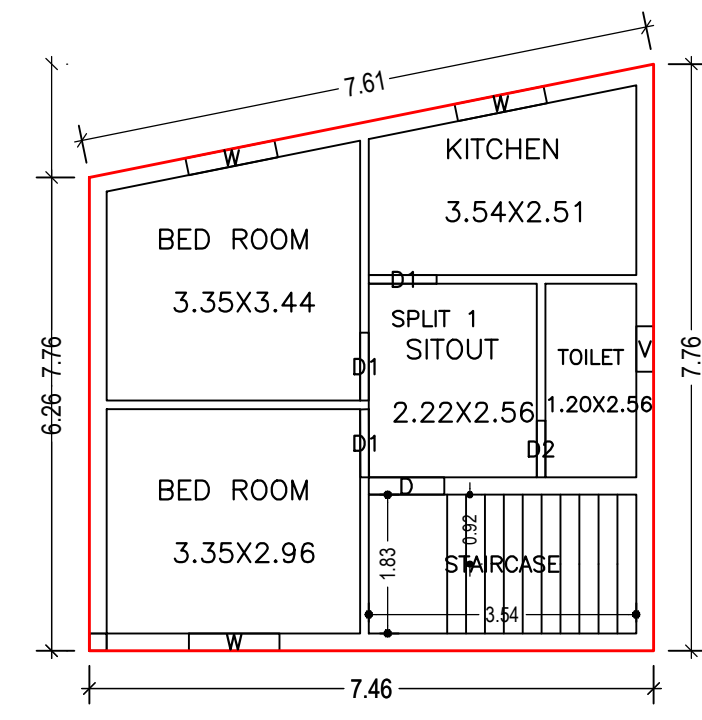

FIRST FLOOR PLAN (Proposed) (SCALE 1:100)

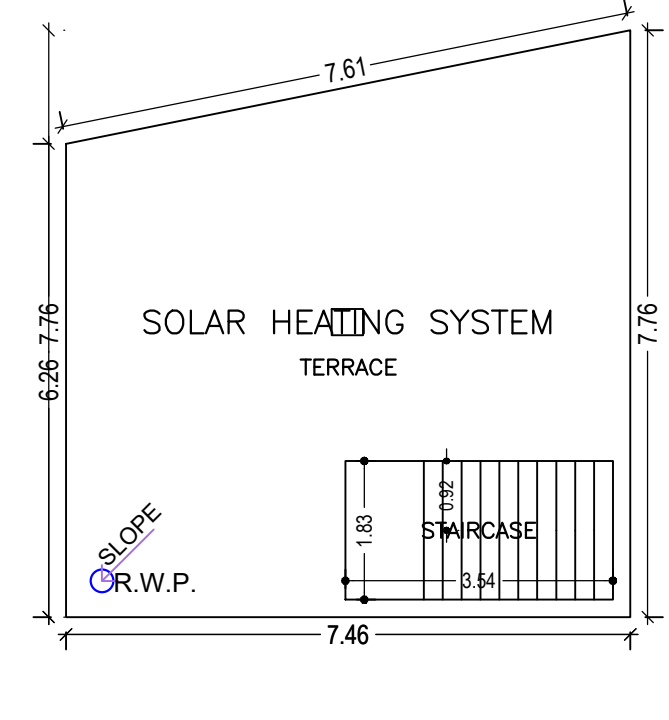

TERRACE FLOOR PLAN (SCALE 1:100)

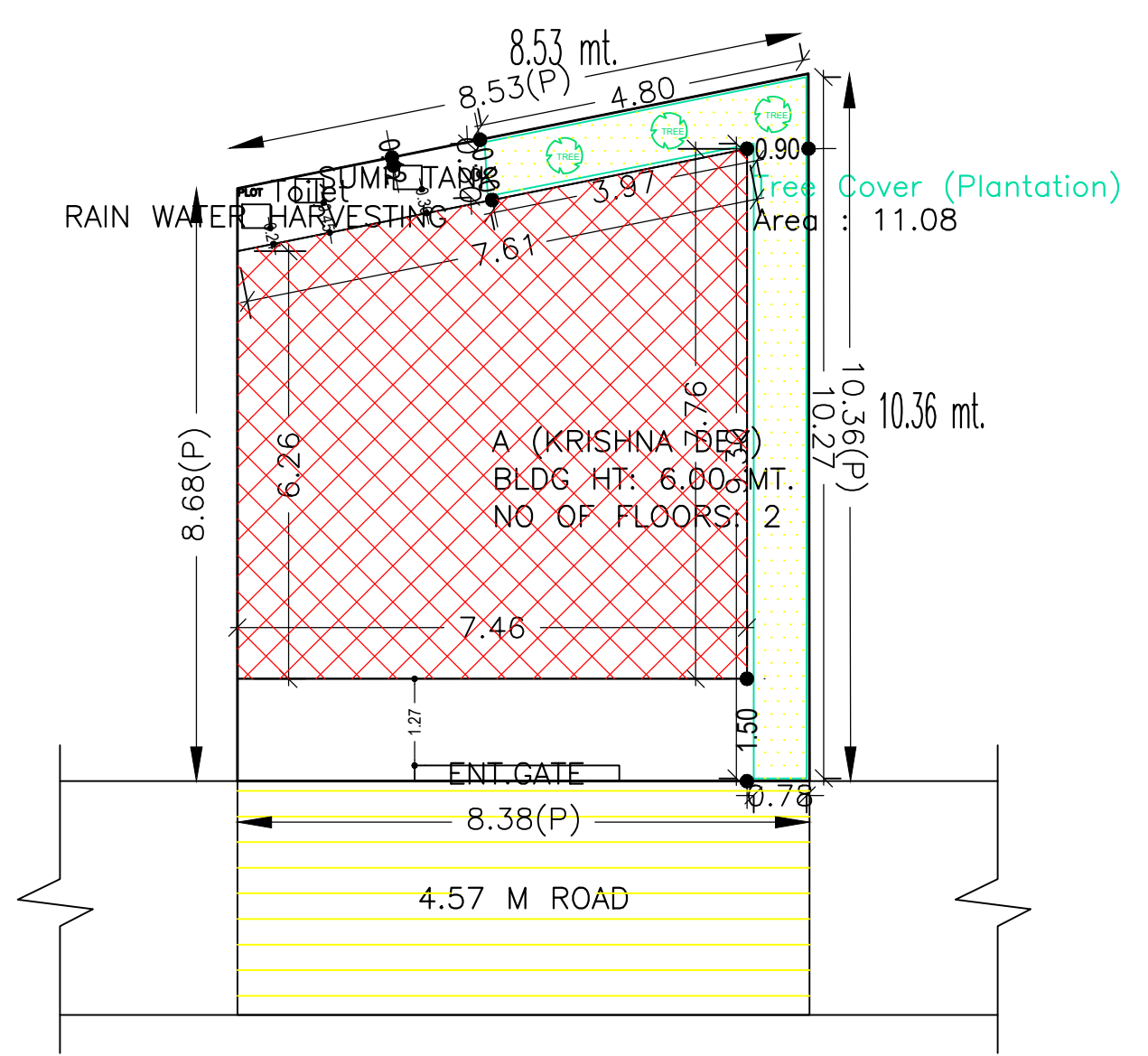

SITE PLAN

Building :A (KRISHNA DEY)

Floor Name	Total Built Up Area (Sq.mt.)	Proposed FAR Area (Sq.mt.) Resi.	Total FAR Area (Sq.mt.)	Total Consumed Additional FAR Area (Sq.mt.)	Trmt (No.)
Ground Floor	52.33	52.33	52.33	52.33	01
First Floor	52.33	52.33	52.33	52.33	00
Terrace Floor	0.00	0.00	0.00	0.00	00
Total :	104.66	104.66	104.66	104.66	01
Total Number of Same Buildings :	1				
Total :	104.66	104.66	104.66	104.66	01

Buildingwise Floor FAR Details

Floor Name	Building Name A (KRISHNA DEY)		Total	
	Proposed Built Up Area (Sq.mt.)	Proposed FAR Area (Sq.mt.)	Total Proposed Built Up Area (Sq.mt.)	Total FAR Area (Sq.mt.)
Ground Floor	52.33	52.33	52.33	52.33
First Floor	52.33	52.33	52.33	52.33
Terrace Floor	0.00	0.00	0.00	0.00
Total :	104.66	104.66	104.66	104.66

UnitBUA Table for Building :A (KRISHNA DEY)

FLOOR	Name	UnitBUA Type	UnitBUA Area	Carpet Area	No. of Rooms	No. of Tenement
GROUND FLOOR PLAN	SPLIT 1	FLAT	104.66	104.55	5	1
FIRST FLOOR PLAN	SPLIT 1	FLAT	0.00	0.00	5	0
Total:	-	-	104.66	104.55	10	1

FAR & Tenement Details (Table 4c-1)

Building	No. of Same Bldg	Total Built Up Area (Sq.mt.)	Proposed FAR Area (Sq.mt.) Resi.	Total FAR Area (Sq.mt.)	Total Consumed Additional FAR Area (Sq.mt.)	Trmt (No.)
A (KRISHNA DEY)	1	104.66	104.66	104.66	104.66	01
Grand Total :	1	104.66	104.66	104.66	104.66	01

SCHEDULE OF DOOR:

BUILDING NAME	NAME	LENGTH	HEIGHT	NOS
A (KRISHNA DEY)	D2	0.75	2.10	02
A (KRISHNA DEY)	D1	0.90	2.10	06
A (KRISHNA DEY)	D	1.00	2.10	02

SCHEDULE OF WINDOW/VENTILATION:

BUILDING NAME	NAME	LENGTH	HEIGHT	NOS
A (KRISHNA DEY)	V	0.60	1.20	02
A (KRISHNA DEY)	W	1.20	1.20	06

Building USE/SUBUSE Details

Building Name	Building Use	Building SubUse	Building Structure
A (KRISHNA DEY)	Residential	Bungalow/ Dwelling / Non Apartment	Non-Highrise

COLOR INDEX

PLOT BOUNDARY	█
ABUTTING ROAD	█
PROPOSED CONSTRUCTION	█
COMMON PLOT	█
ROAD WIDENING AREA	█
EXISTING (To be retained)	█
EXISTING (To be demolished)	█

LTP NAME AND SIGNATURE	STRUCTURAL ENG'S NAME AND SIGNATURE	BUILDER NAME AND SIGNATURE	DIGITAL SIGNATURE
RAVI KUMAR CMC/DFTMN/024/2017			