

Proposal Basic Information	
Proposal File No.	CMC/BP/0165/W28/2022
Owner Name	SHRI RAM SAGAR SHARMA
Khata No	112
Plot No	7336,7337
Village Name	Chas
Use	Residential
SubUse	Bungalow/ Dwelling / Non Apartment

AREA STATEMENT CHAS MUNICIPAL CORPORATION		VERSION NO. : 1.0.62	SQ. MT.
PROJECT DETAIL:		VERSION DATE: 16/10/2020	
Region: JHARKHAND URBAN LOCAL BODIES	Plot Use: Residential		
District: BOKARO	Plot SubUse: Bungalow/ Dwelling / Non Apartment		
Authority: CHAS MUNICIPAL CORPORATION	PlotNearbyReligiousStructure: NA		
Inward No: CMC/BP/0165/W28/2022	Plot/SubPlot No: 7336,7337		
Application Type: General Proposal	North: CTS No. - NIJ		
Project Type: Building Permission	South: Road Width - 3.65		
Nature of Development: New	East: CTS No. - RAJ KUMARI DEVI		
Location of Development Area: Old Area	West: CTS No. - BHAGYA MANI DEVI		
AREA DETAILS:			
AREA OF PLOT (Minimum)	(A)	150.76	
NET AREA OF PLOT(Gross Plot Area - Deduction from Gross Plot area)	(A-Deductions)	150.76	
Deduction for Balance Plot Area(from Gross Plot Area)			
Common Plot		12.79	
Total		12.79	
BALANCE AREA OF PLOT(Net Plot Area - Recreational/Amenity space)	(A-Deductions)	137.97	
PLOT AREA FOR COVERAGE(Net Plot Area)	(A-Deductions)	150.76	
Plot Area for FAR (Net Plot Area + Road Widening Area)	(A-Deductions)	150.76	
COVERAGE CHECK			
Permissible Coverage area (70.00 %)		105.53	
Proposed Coverage Area (54.65 %)		82.39	
Total Prop. Coverage Area (54.65 %)		82.39	
Balance coverage area (15.35 %)		23.14	
FAR CHECK			
Perm. FAR Area (1.50)		226.14	
Total Perm. FAR area		226.14	
Residential FAR		149.47	
Proposed FAR Area		149.47	
Total Proposed FAR Area		149.47	
Consumed FAR (Factor)		0.99	
Balance FAR Area		76.67	
BUILT UP AREA CHECK			
Total Proposed BuiltUp Area		164.78	
ARCHITECT (Regd)		RAGHUNATH MAHATO	
ENGINEER (Regd)			
SUPERVISOR (Regd)			
OWNER (Regd)		SHRI RAM SAGAR SHARMA	
DEVELOPMENT AUTHORITY		LOCAL BODY	

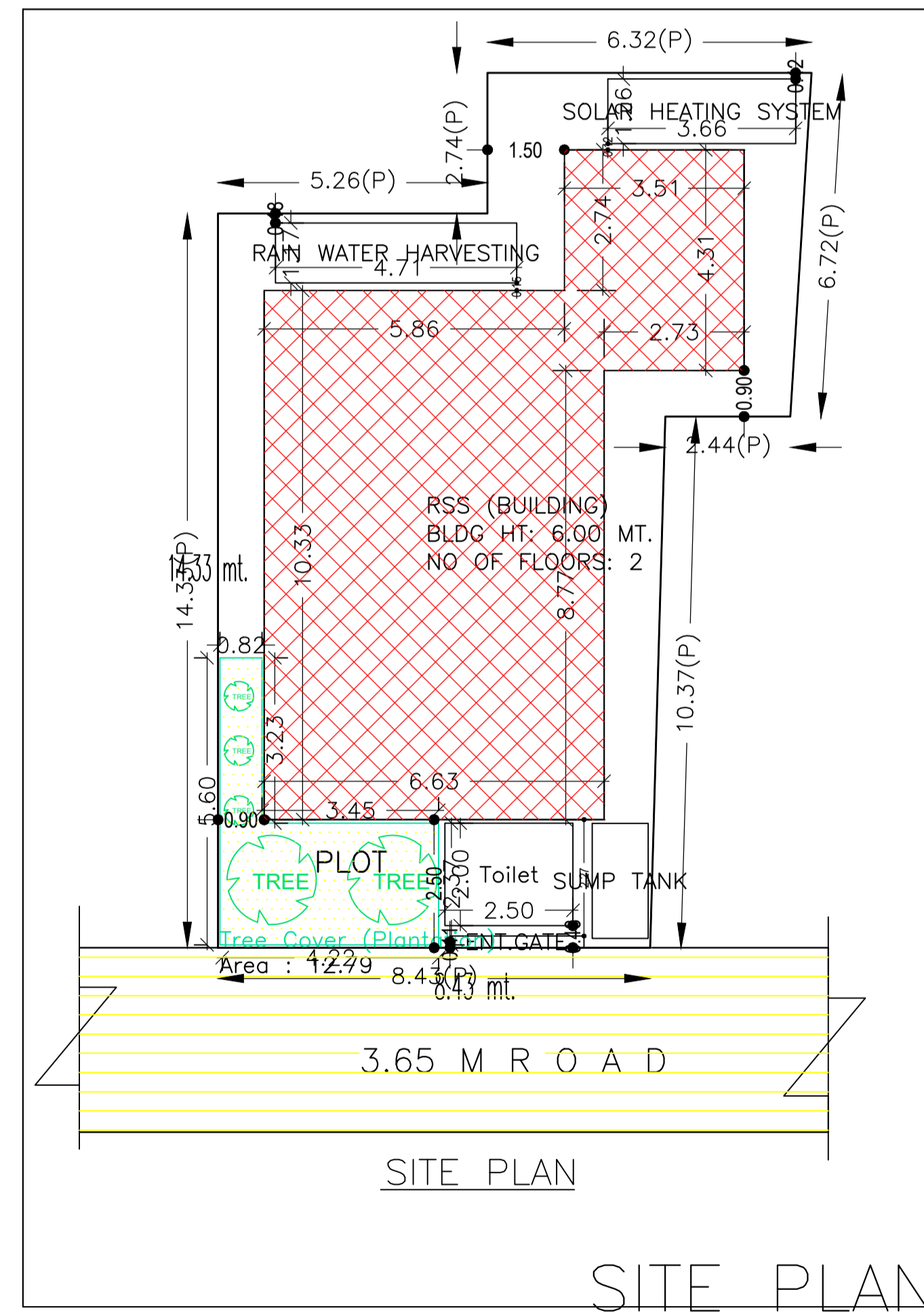
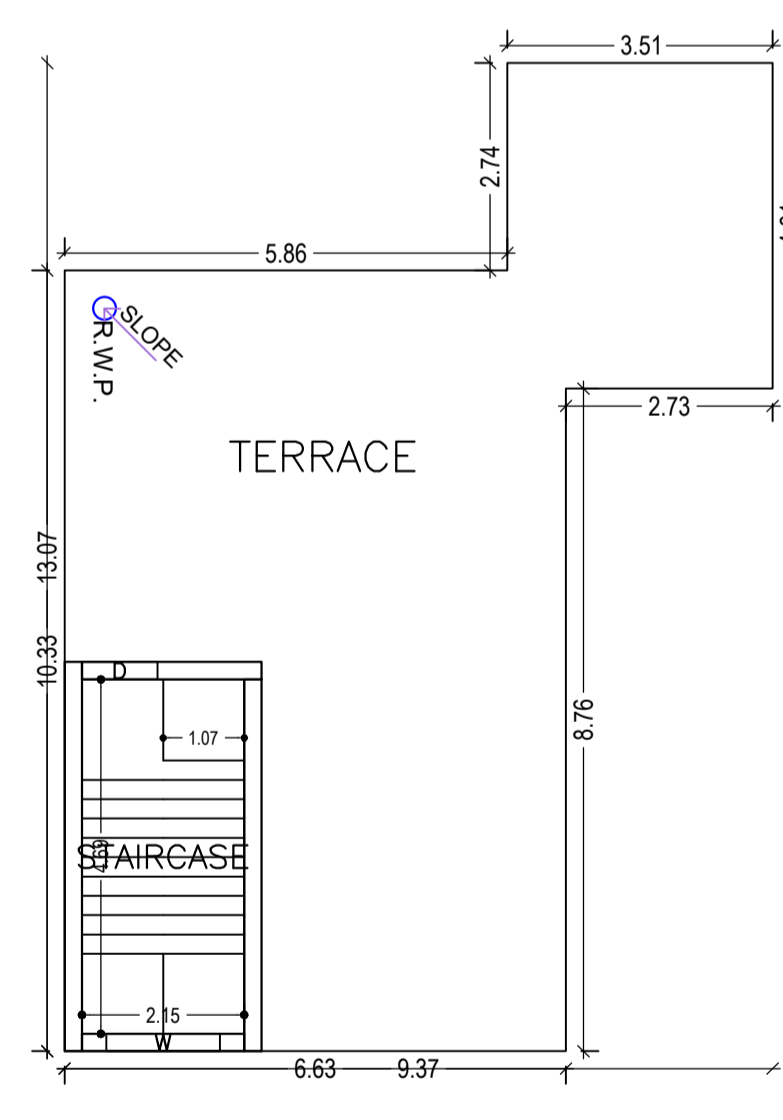
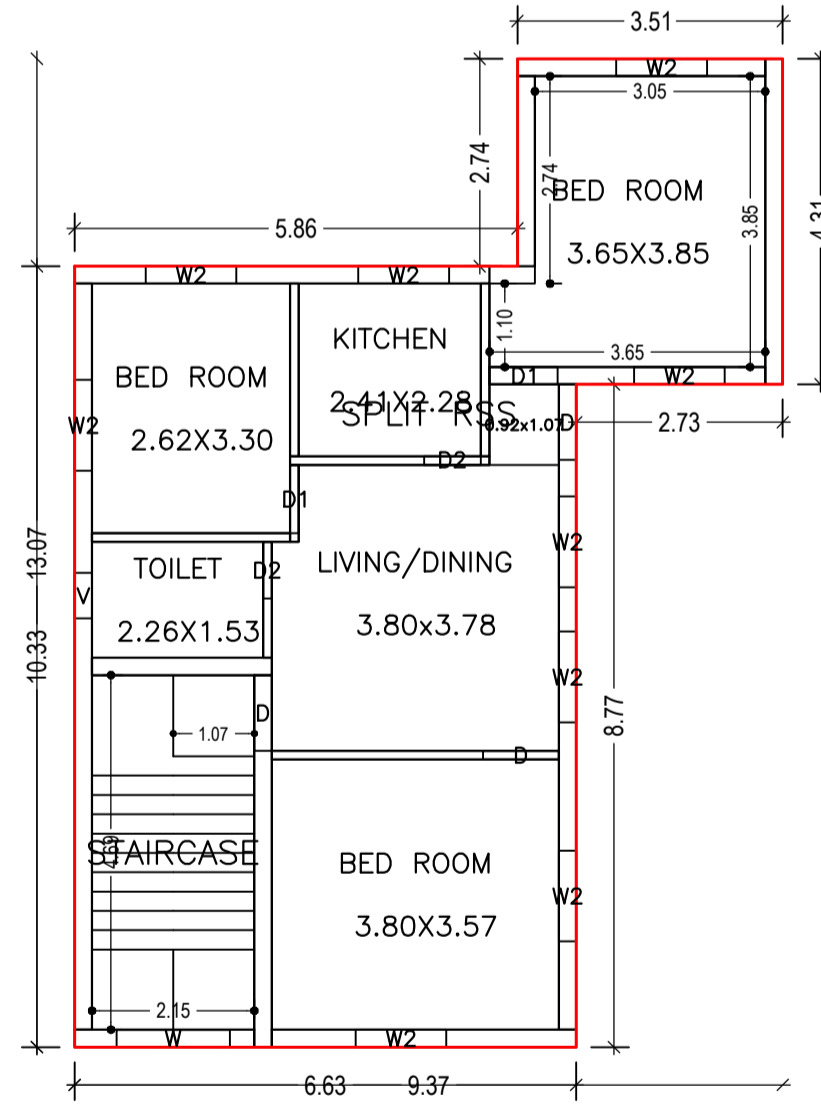
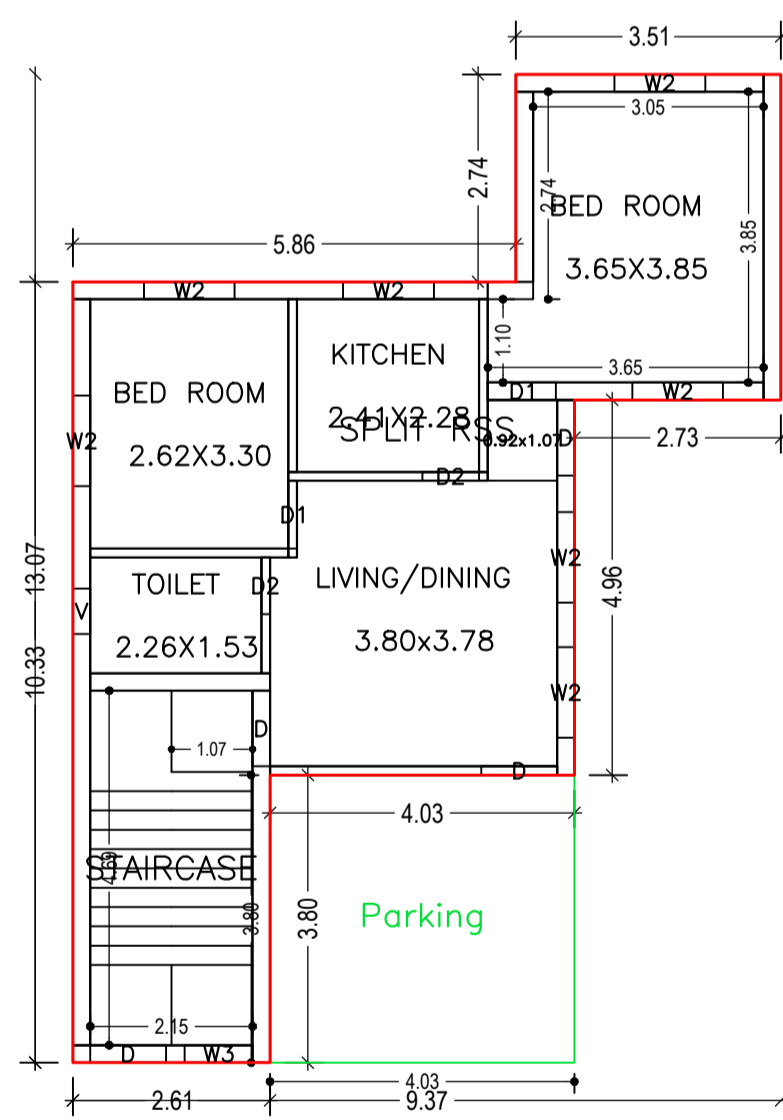
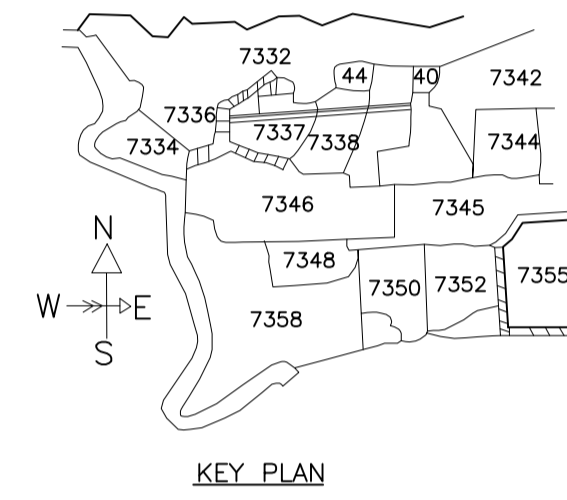
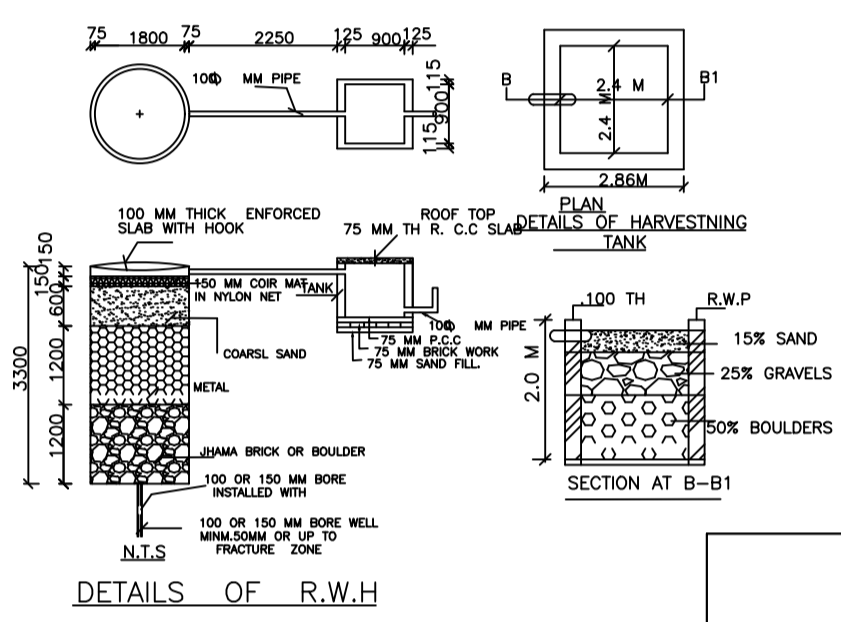
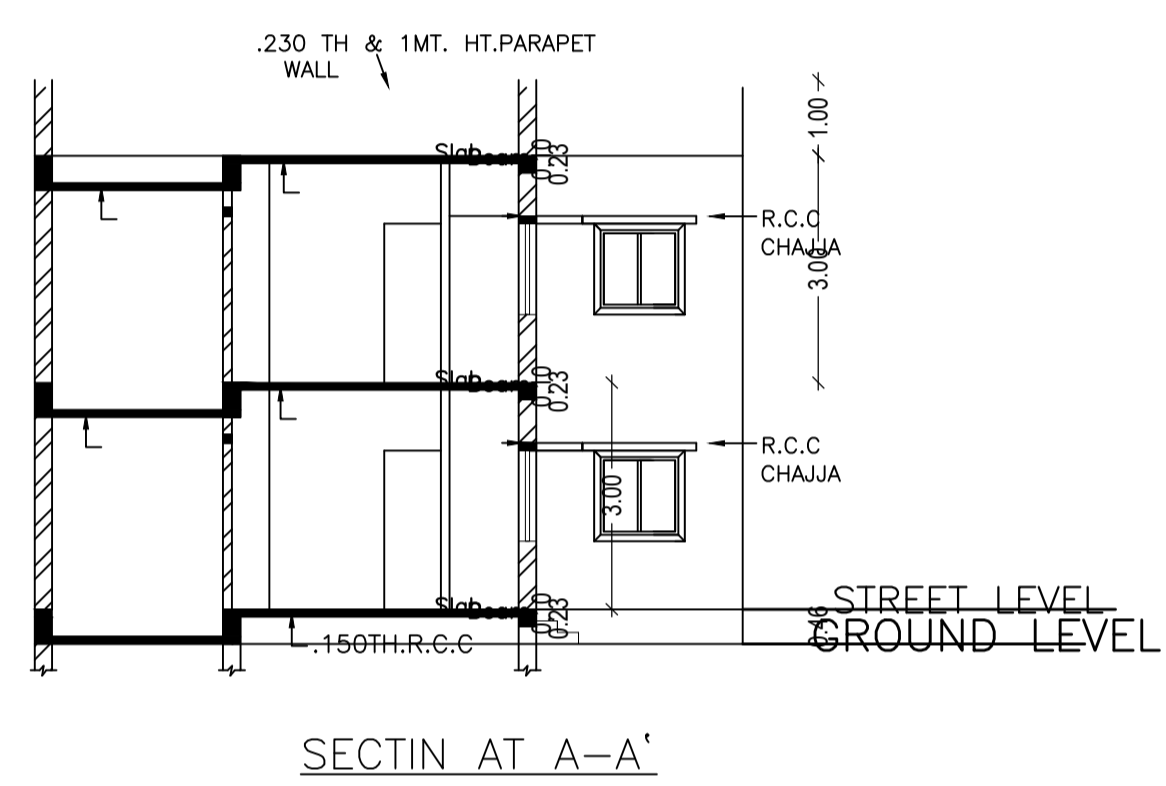
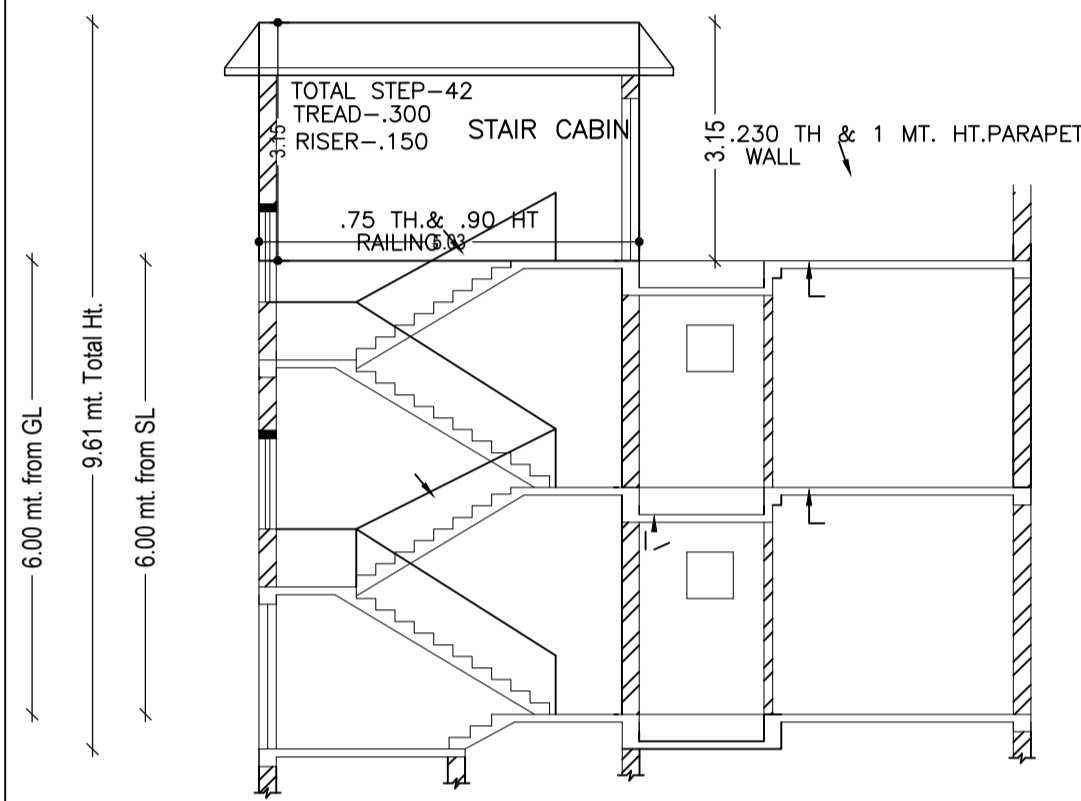

Building :RSS (BUILDING)

Floor Name	Total Built Up Area (Sq.mt.)	Deductions (Area in Sq.mt.)	Proposed FAR Area (Sq.mt.)	Total FAR Area (Sq.mt.)	Total Consumed Additional FAR Area (Sq.mt.)	Tnmt (No.)
Ground Floor	82.39	15.31	67.08	67.08	67.08	01
First Floor	82.39	0.00	82.39	82.39	82.39	00
Terrace Floor	0.00	0.00	0.00	0.00	0.00	00
Total :	164.78	15.31	149.47	149.47	149.47	01
Total Number of Same Buildings :	1					
Total :	164.78	15.31	149.47	149.47	149.47	01

Buildingwise Floor FAR Details

Floor Name	Building Name		Total	
	Proposed Built Up Area (Sq.mt.)	Proposed FAR Area (Sq.mt.)	Total Proposed Built Up Area (Sq.mt.)	Total FAR Area (Sq.mt.)
Ground Floor	82.39	67.08	82.39	67.08
First Floor	82.39	82.39	82.39	82.39
Terrace Floor	0.00	0.00	0.00	0.00
Total :	164.78	149.47	164.78	149.47

SCHEDULE OF DOOR:

BUILDING NAME	NAME	LENGTH	HEIGHT	NOS
RSS (BUILDING)	D2	0.75	2.10	04
RSS (BUILDING)	D1	0.90	2.10	04
RSS (BUILDING)	D	1.00	2.10	06

SCHEDULE OF WINDOW/VENTILATION:

BUILDING NAME	NAME	LENGTH	HEIGHT	NOS
RSS (BUILDING)	V	0.60	0.60	02
RSS (BUILDING)	V3	0.90	1.20	01
RSS (BUILDING)	W2	1.20	1.20	16
RSS (BUILDING)	W	1.50	1.20	01

FAR & Tenement Details (Table 4c-1)

UnitBUA Table for Building :RSS (BUILDING)

FLOOR	Name	UnitBUA Type	UnitBUA Area	Carpent Area	No. of Rooms	No. of Tenement
GROUND FLOOR	SPLIT RSS	FLAT	107.18	103.90	5	1
FIRST FLOOR	SPLIT RSS	FLAT	0.00	0.00	6	0
Total:	-	-	107.18	103.90	11	1

Building	No. of Same Bldg	Total Built Up Area (Sq.mt.)	Deductions (Area in Sq.mt.)	Proposed FAR Area (Sq.mt.)	Total FAR Area (Sq.mt.)	Total Consumed Additional FAR Area (Sq.mt.)	Tnmt (No.)
RSS (BUILDING)	1	164.78	15.31	149.47	149.47	149.47	01
Grand Total :	1	164.78	15.31	149.47	149.47	149.47	01

COLOR INDEX		LTP NAME AND SIGNATURE	STRUCTURAL ENG'S NAME AND SIGNATURE	BUILDER NAME AND SIGNATURE	DIGITAL SIGNATURE
█	PLOT BOUNDARY	RAGHUNATH MAHATO			
█	ABUTTING ROAD	CMC/DFTM/0033/2017			
█	PROPOSED CONSTRUCTION				
█	COMMON PLOT				
█	ROAD WIDENING AREA				
█	EXISTING (To be retained)				
█	EXISTING (To be demolished)				

Building USE/SUBUSE Details

Building Name	Building Use	Building SubUse	Building Structure
RSS (BUILDING)	Residential	Bungalow/ Dwelling / Non Apartment	Non-Highrise