

Proposal Basic Information

Proposal File No.	CMC/BP/0146/W03/2022
Owner Name	SMT POONAM KUMARI
Khata No	456
Plot No	997
Village Name	Chas
Use	Mixed
SubUse	Res+Comm

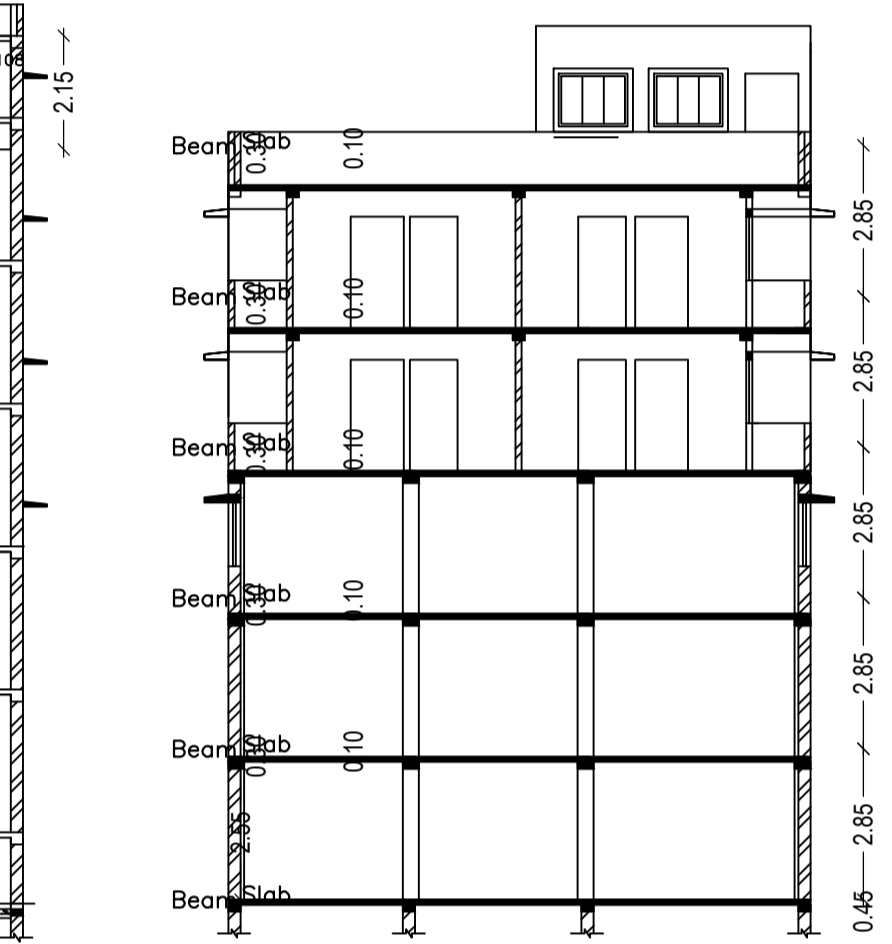
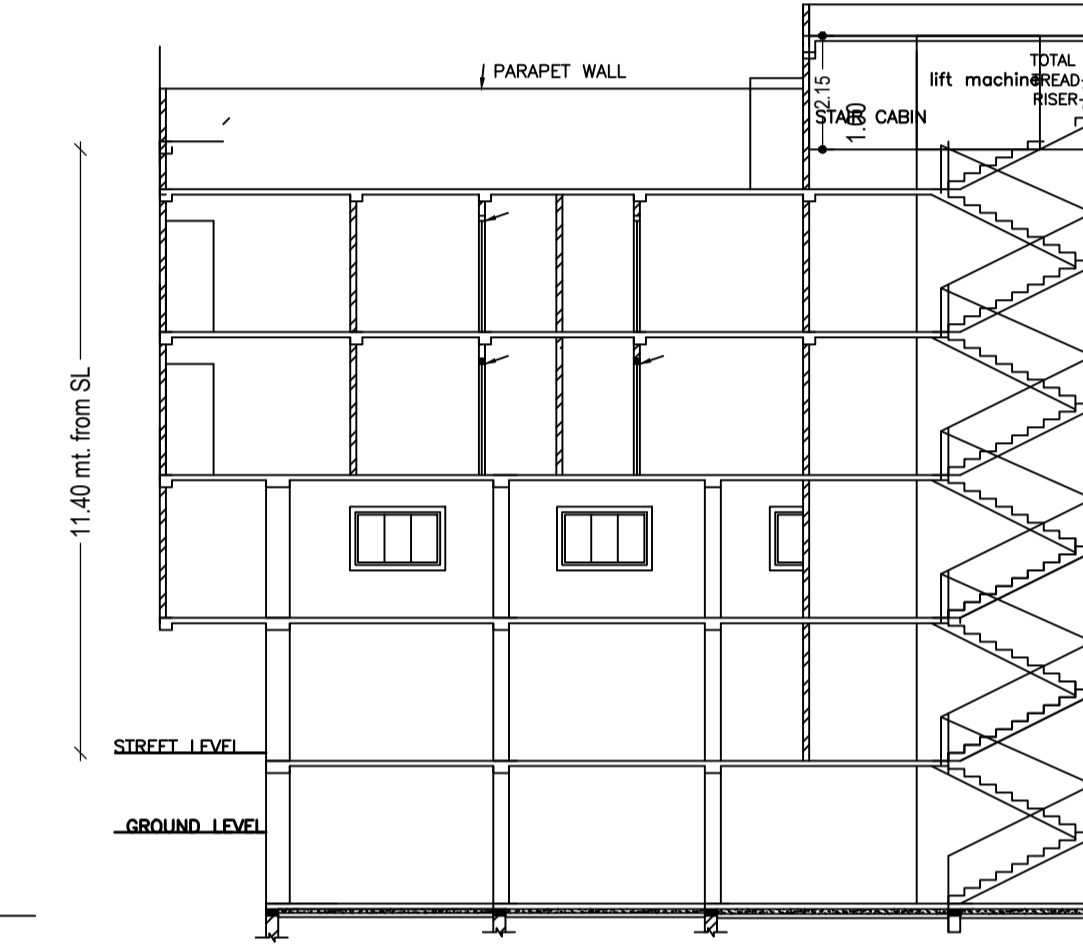
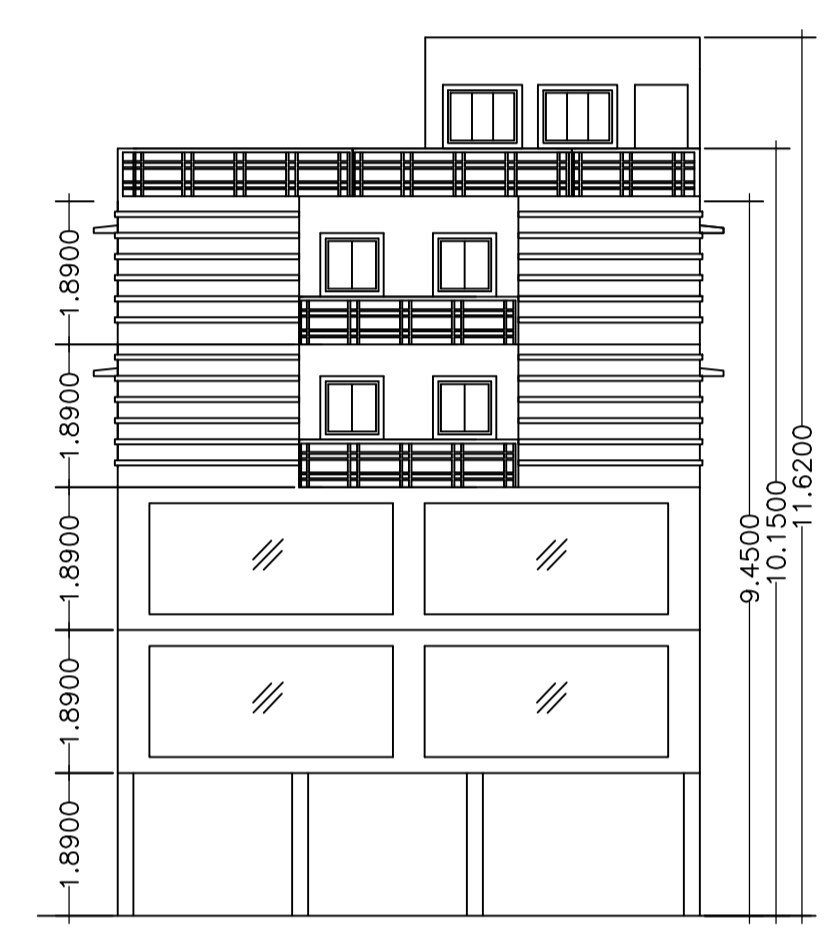
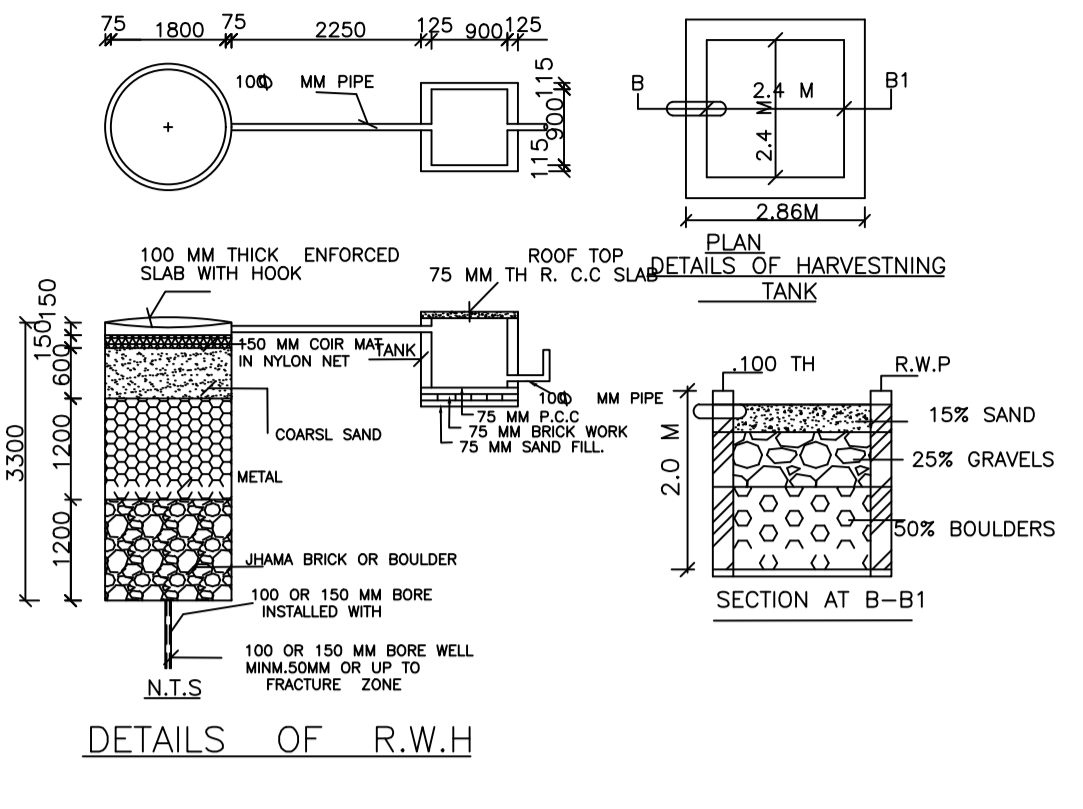
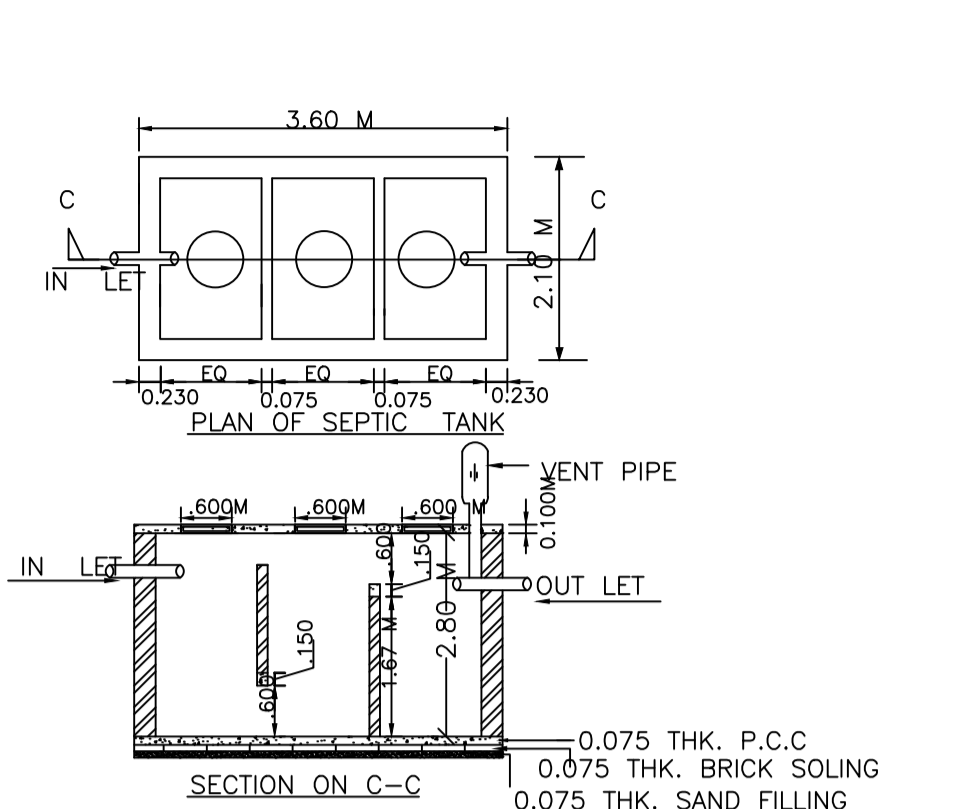
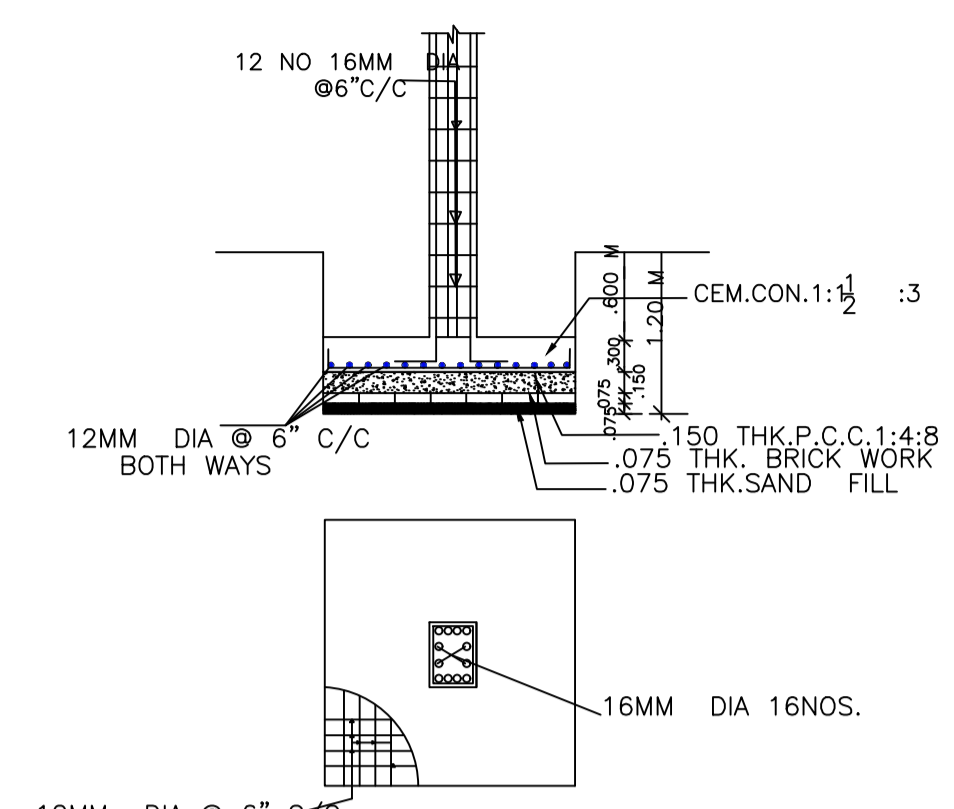
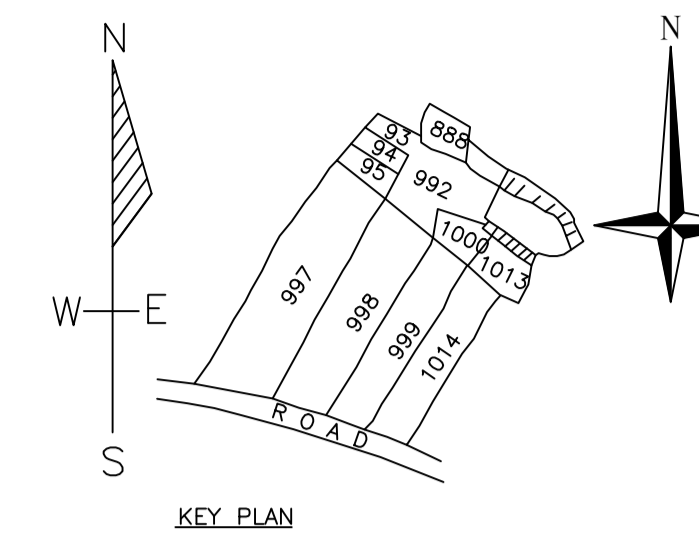

FRONT ELEVATION

RIGHT SIDE ELEVATION

SECTION AT B-B'

SECTION AT A-A'

Required Parking (Table 7a)

Building Name	Type	SubUse	Area (Sq.mt)		Car		Visitors Car		TwoWheeler		
			Reqd	Prop	Reqd	Prop	Reqd	Prop	Reqd	Prop	
A (BUILDING)	Residential	ResComm Bldg	>0	1	2.00	1.00	2	-	-	-	-
			>0	1	2.00	-	-	1	1	-	-
			>0	100	32.73	1	3	-	-	-	-
Commercial			>0	100	32.73	-	5	8	-	1	1
Total			-	-	-	-	-	-	9	16	

Parking Check (Table 7b)

Vehicle Type	Reqd		Prop	
	No.	Area	No.	Area
Car	-	-	8	100.00
Visitors Car Parking	5	62.50	1	100.00
Total Visitor Parking	1	12.50	1	12.50
TwoWheeler	-	-	16	32.00
Total TwoWheeler	8	16.00	16	32.00
Other Parking	-	-	-	-
Total	-	93.00	-	265.07

AREA STATEMENT CHAS MUNICIPAL CORPORATION		VERSION NO. 1.0.62	VERSION DATE 16/10/2020
PROJECT DETAIL		Plot Use: Mixed	444.72
Region: BHARHAR URBAN LOCAL BODIES		Plot SubUse: Res+Comm	444.72
District: BHARHAR		Plot/Religious/Structure: NA	444.72
Authority: CHAS MUNICIPAL CORPORATION		Plot/Religious/Structure: NA	444.72
Inward No: CMC/BP/0146/W03/2022		Plot/Religious/Structure: NA	444.72
Application Type: General Proposal		North Plot No.: 997 PART OF PLOT	444.72
Project Type: Building Permission		South Plot No.: 12.20	444.72
Nature of Development: New		East Plot No.: 997 PART OF PLOT	444.72
Location of Development Area: Old Area		West Plot No.: 997 PART OF PLOT	444.72
AREA DETAILS		Area of Plot (Minimum)	50 MT
KEY AREA OF PLOT/Gross Plot Area		(A)	444.72
Deduction from Gross Plot Area		(A-Deductions)	444.72
Deduction for Balance Plot Area/From Gross Plot Area			66.39
Common Plot			66.39
BALANCE AREA OF PLOT/Net Plot Area - Recreational/Amenity		(A-Deductions)	378.34
PLOT AREA FOR COVERAGE/Net Plot Area		(A-Deductions)	444.72
PLOT AREA FOR FAR (Net Plot Area + Road/Widening Area)		(A-Deductions)	444.72
COVERAGE CHECK			
Permissible Coverage Area (60.00 %)			266.83
Proposed Coverage Area (42.14 %)			187.39
Total Prop. Coverage Area (42.14 %)			187.39
Balance coverage area (17.86 %)			79.44
FAR CHECK			
Perm. FAR Area (2.50)			1111.80
Total Perm. FAR area			1111.80
Residential FAR			422.83
Commercial FAR			378.81
Proposed FAR Area			807.14
Total Proposed FAR Area			807.14
Consumed FAR (Factory)			1.87
Balance FAR Area			304.66
BUILT UP AREA CHECK			
Total Proposed Builtup Area			988.05
ARCHITECT (Regd)		SUBHASH NARHARRAO NETRAGAONKAR	
ENGINEER (Regd)		SUBHASH NARHARRAO NETRAGAONKAR	
SUPERVISOR (Regd)		SMT POONAM KUMARI	
OWNER (Regd)		SMT POONAM KUMARI	
DEVELOPMENT AUTHORITY		LOCAL BODY	

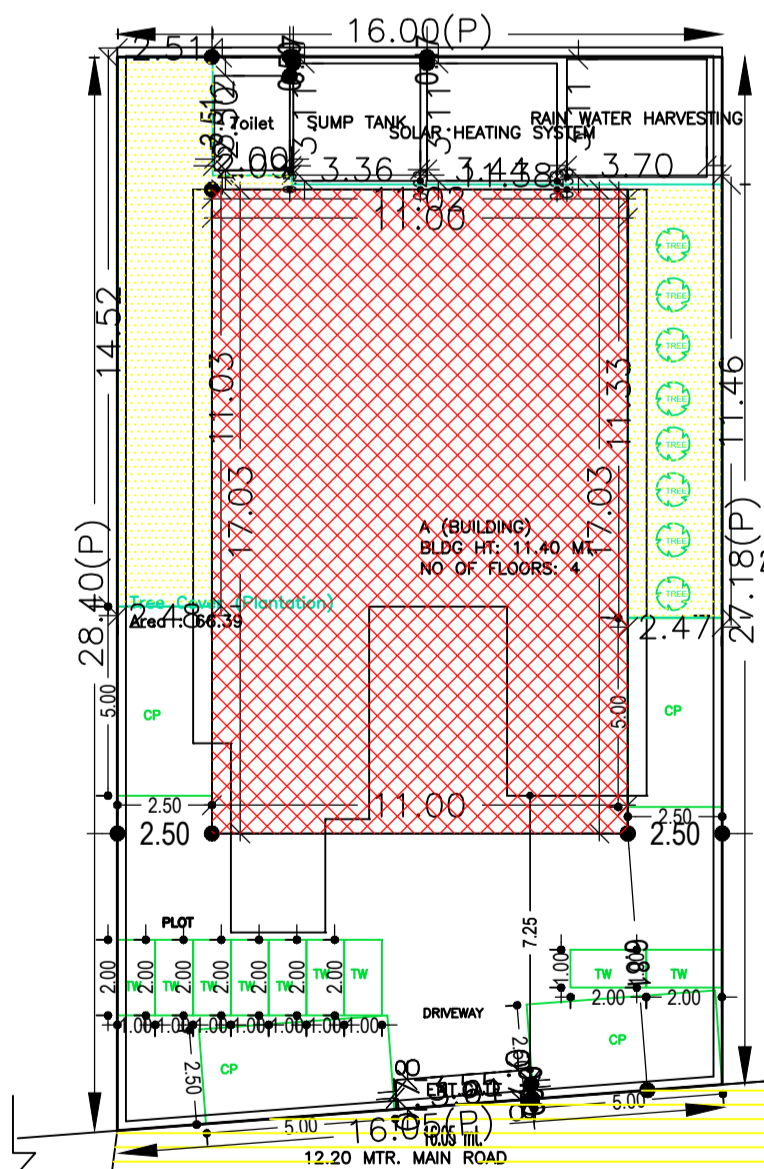
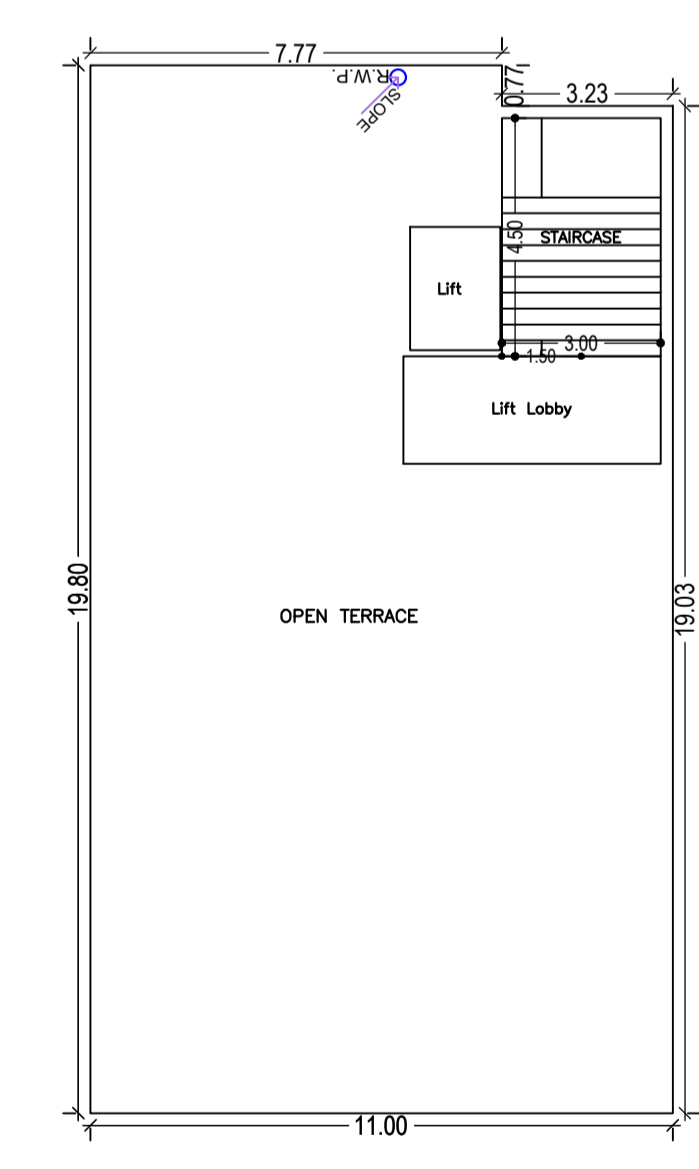
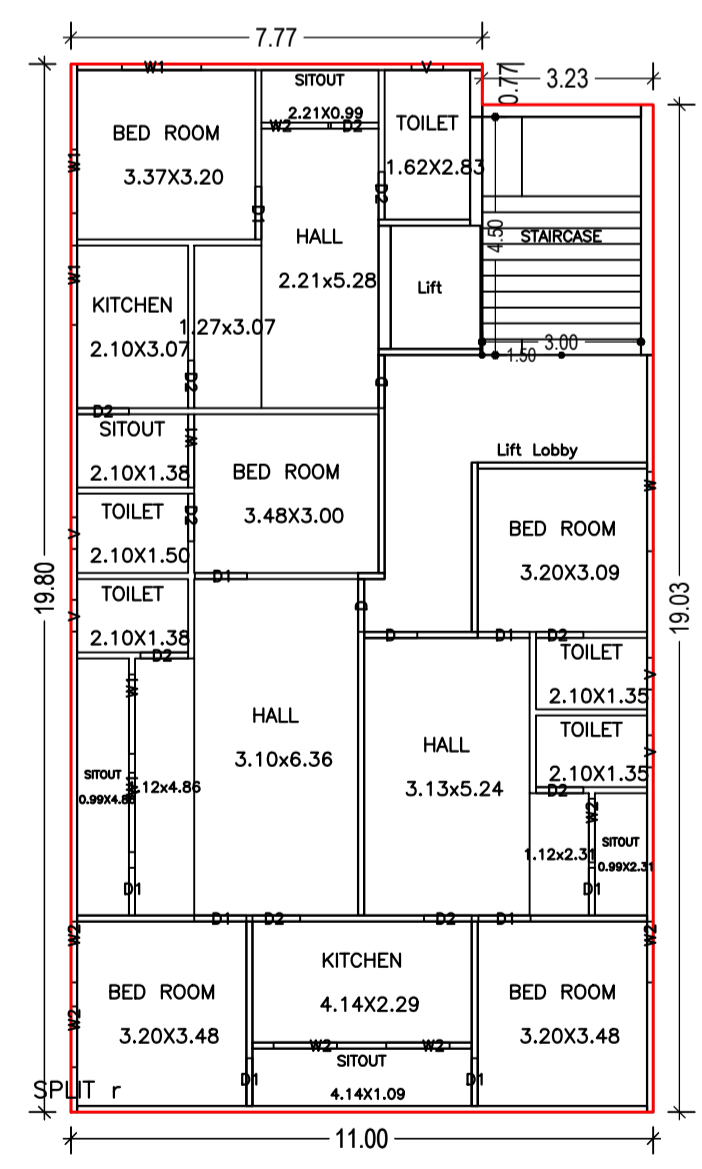
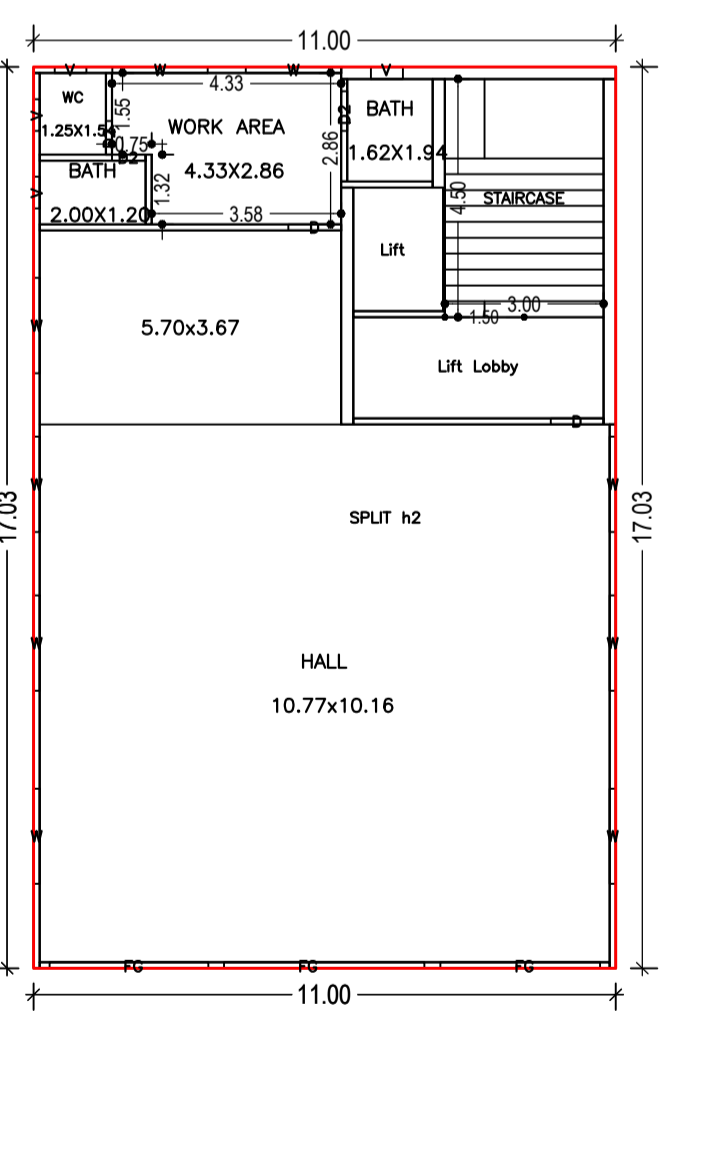
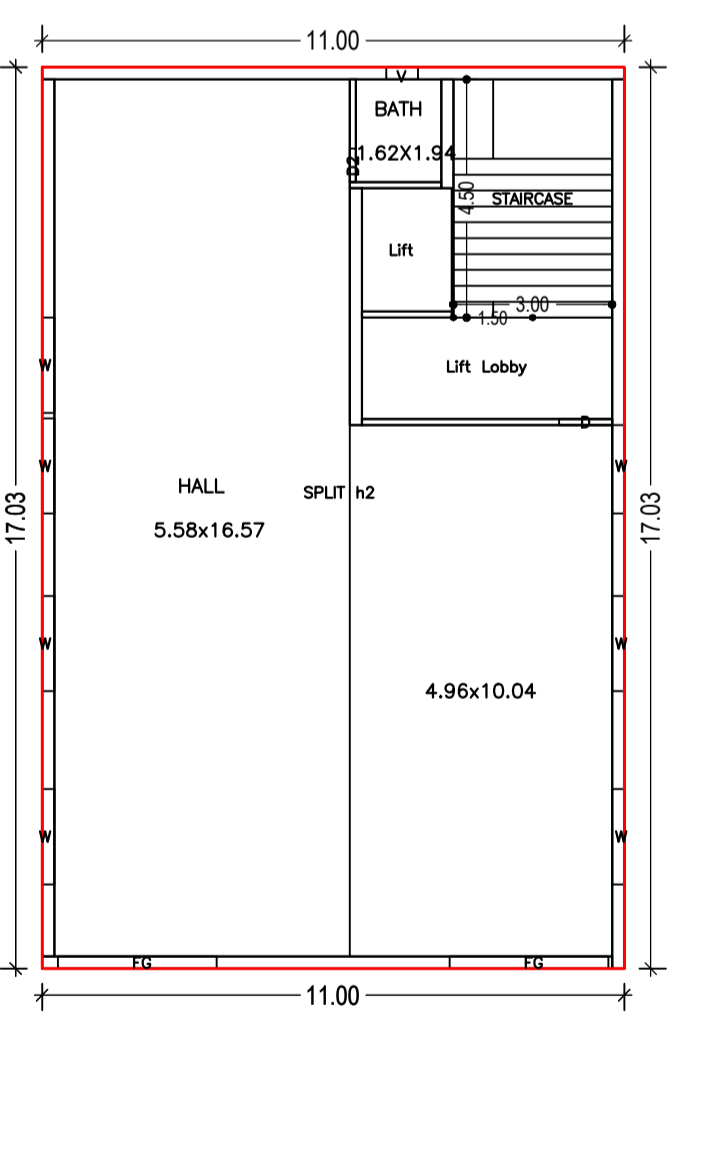
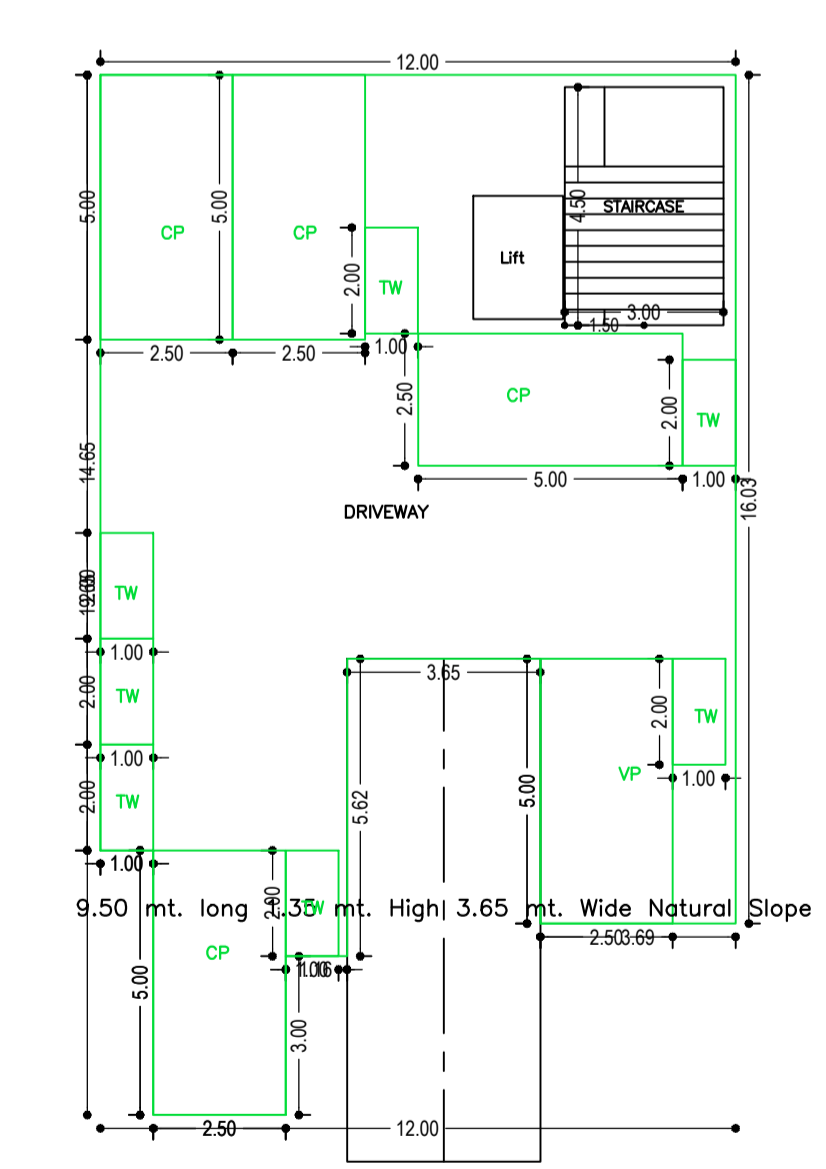

BASEMENT FLOOR PLAN (SCALE 1:100)

GROUND FLOOR PLAN (Proposed) (SCALE 1:100)

FIRST FLOOR PLAN (Proposed) (SCALE 1:100)

TYPICAL - 2&3 FLOOR PLAN (Proposed) (SCALE 1:100)

TERRACE FLOOR PLAN (SCALE 1:100)

SITE PLAN

SCHEDULE OF DOOR:

BUILDING NAME	NAME	LENGTH	HEIGHT	NOS
A (BUILDING)	D2	3.94	2.10	03
A (BUILDING)	D2	0.75	2.10	01
A (BUILDING)	D2	0.90	2.10	18
A (BUILDING)	D1	0.90	2.10	08
A (BUILDING)	D2	0.99	2.10	02
A (BUILDING)	D1	0.99	2.10	08
A (BUILDING)	D	1.00	2.10	08
A (BUILDING)	D1	1.00	2.10	02

SCHEDULE OF WINDOW/VENTILATION:

BUILDING NAME	NAME	LENGTH	HEIGHT	NOS
A (BUILDING)	V	0.60	1.20	15
A (BUILDING)	W2	1.15	1.20	06
A (BUILDING)	W1	1.20	1.20	02
A (BUILDING)	W2	1.20	1.20	06
A (BUILDING)	W2	1.26	1.20	02
A (BUILDING)	W1	1.36	1.20	02
A (BUILDING)	W1	1.50	1.20	08
A (BUILDING)	W	1.50	1.20	02
A (BUILDING)	W	1.87	1.20	01
A (BUILDING)	W	1.80	1.20	15
A (BUILDING)	FG	3.00	1.20	03
A (BUILDING)	FG	3.02	1.20	01
A (BUILDING)	FG	3.79	1.20	01

Building : A (BUILDING)

Floor Name	Total Built Up Area (Sq.mt)	Deductions (Area in Sq.mt)	Proposed FAR Area (Sq.mt)	Add Area in FAR (Sq.mt)	Total FAR Area (Sq.mt)	Total Consumed FAR Area (Sq.mt)	Trmt (No.)
Basement Floor	182.53	3.96	168.07	0.00	13.50	13.50	00
Ground Floor	187.39	0.00	0.00	0.00	187.39	187.39	01
First Floor	187.39	3.96	0.00	0.00	183.43	183.43	01
Second Floor	215.37	3.96	0.00	0.00	211.41	211.41	01
Third Floor	215.37	3.96	0.00	0.00	211.41	211.41	01
Terrace Floor	0.00	0.00	0.00	0.00	0.00	0.00	00
Total	988.05	15.84	165.07	422.82	370.81	13.50	807.14
Total Number of Same Buildings	1	-	-	-	-	-	04

Building USE/SUBUSE Details

Building Name	Building Use	Building SubUse	Building Structure
A (BUILDING)	Residential	Res+Comm Bldg	Non-Highrise

Buildingwise Floor FAR Details

Floor Name	Building Name	Proposed Built Up Area (Sq.mt)	Proposed FAR Area (Sq.mt)	Total FAR Area (Sq.mt)
Basement Floor	A (BUILDING)	182.53	13.50	13.50
Ground Floor	A (BUILDING)	187.39	187.39	187.39
First Floor	A (BUILDING)	187.39	183.43	183.43
Second Floor	A (BUILDING)	215.37	211.41	211.41
Third Floor	A (BUILDING)	215.37	211.41	211.41
Terrace Floor	A (BUILDING)	0.00	0.00	0.00
Total	A (BUILDING)	988.05	807.14	807.14

FAR & Tenement Details (Table 4c-1)

Building	No. of Same Bldg	Total Built Up Area (Sq.mt)	Deductions (Area in Sq.mt)	Proposed FAR Area (Sq.mt)	Add Area in FAR (Sq.mt)	Total FAR Area (Sq.mt)	Total Consumed FAR Area (Sq.mt)	Trmt (No.)
A (BUILDING)	1	988.05	15.84	165.07	422.82	370.81	13.50	807.14
Grand Total	1	988.05	15.84	165.07	422.82	370.81	13.50	807.14

UnitBUA Table for Building : A (BUILDING)

FLOOR	Name	UNB/UA Type	UNB/UA Area (Sq.mt)	Carpet Area (Sq.mt)	No. of Rooms	No. of Tenement
TYPICAL - 2&3 FLOOR PLAN	SPLIT-1	FLAT	171.03	169.53	20	2
FIRST FLOOR PLAN	SPLIT H2	SHOP	150.62	149.19	5	1
GROUND FLOOR PLAN	SPLIT H2	SHOP	147.98	147.76	2	1
Total	-	-	640.66	636.47	47	4

COLOR INDEX

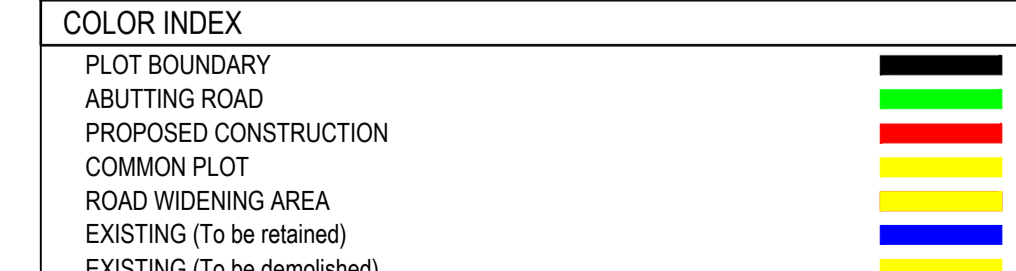

LTP NAME AND SIGNATURE	STRUCTURAL ENG'S NAME AND SIGNATURE	BUILDER NAME AND SIGNATURE	DIGITAL SIGNATURE
SUBHASH NARHARRAO NETRAGAONKAR CMC/ARC/0014/2018			