

FRONT ELEVATION

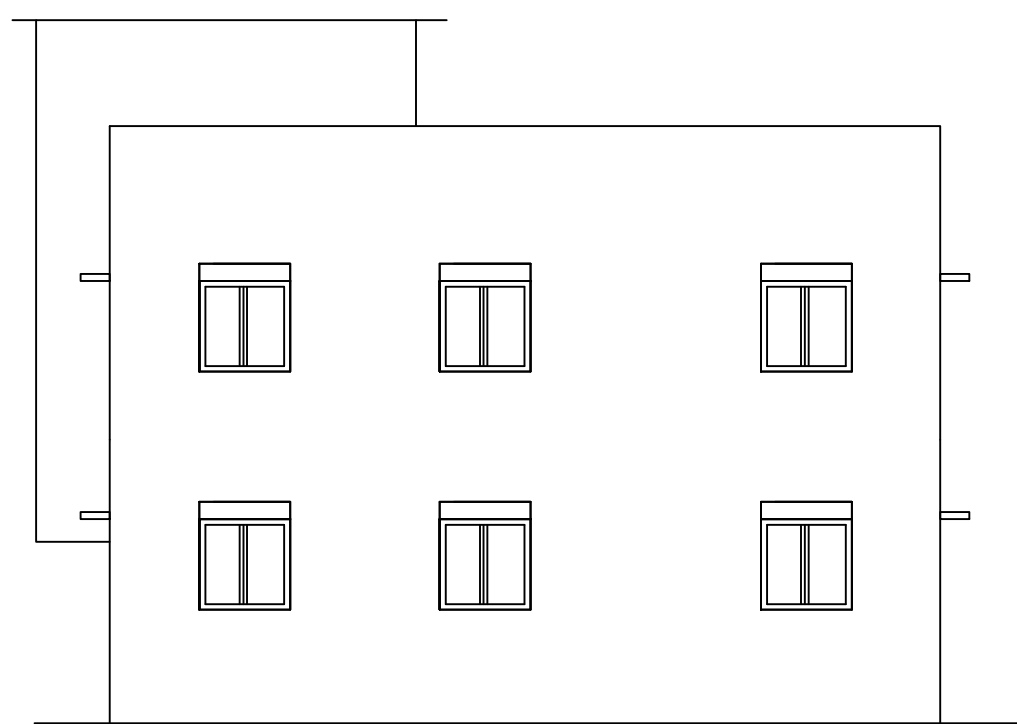

RIGHT SIDE ELEVATION

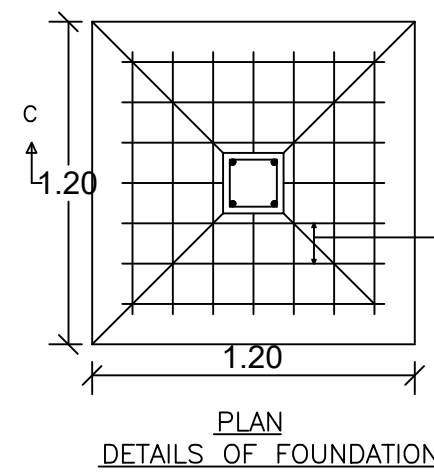

DETAILS OF FOUNDATION

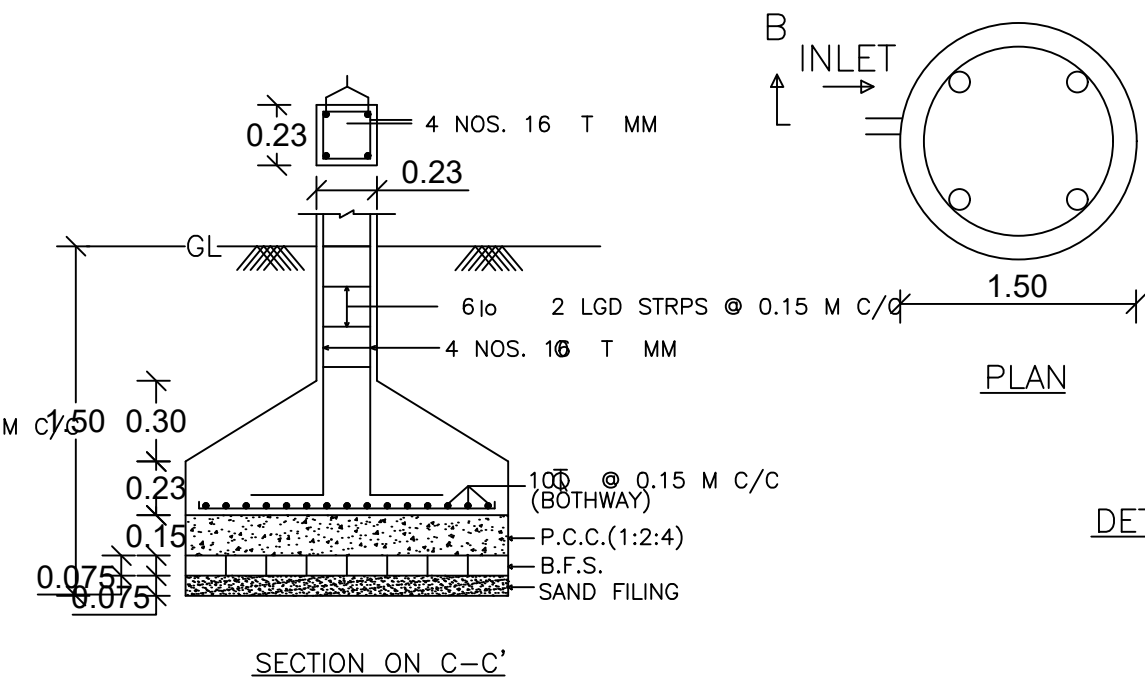

SECTION ON C-C'

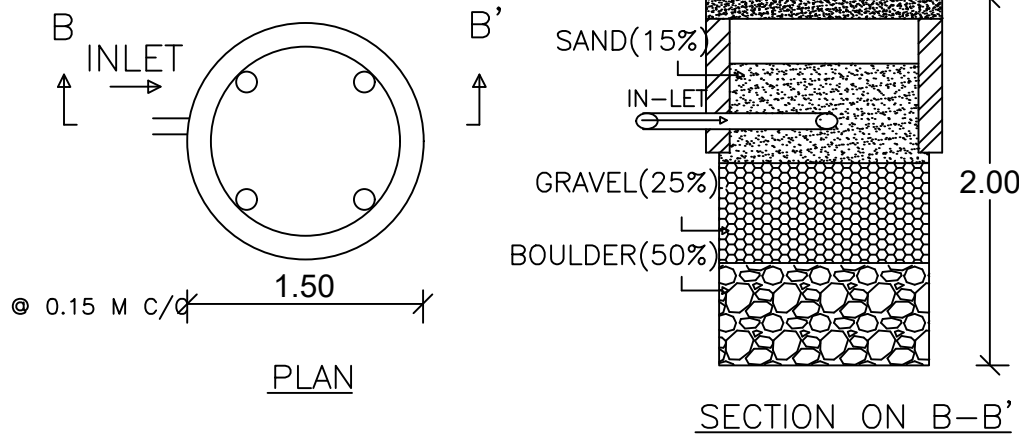

SECTION ON B-B'

DETAILS OF WATER HARVESTING

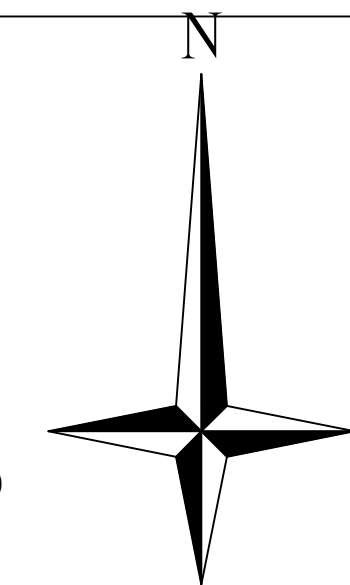

Proposal Basic Information	
Proposal File No.	CMC/BP/0230/W11/2022
Owner Name	KAMLA KANT MISHRA
Khata No	393,274
Plot No	6233,6234
Village Name	Chas
Use	Residential
SubUse	Bungalow/ Dwelling / Non Apartment

AREA STATEMENT CHAS MUNICIPAL CORPORATION		VERSION NO. : 1.0.66
PROJECT DETAIL:		VERSION DATE: 16/10/2020
Region: JHARKHAND URBAN LOCAL BODIES	Plot Use: Residential	
District: BOKARD	Plot SubUse: Bungalow/ Dwelling / Non Apartment	
Authority: CHAS MUNICIPAL CORPORATION	PlotNearby/ReligiousStructure: NA	
Inward No: CMC/BP/0230/W11/2022	Plot/SubPlot No: 6233,6234	
Application Type: General Proposal	North: CTS No. - PANDEY JI.DR. N.K.SINGH AND NAKUL SINGH	
Project Type: Building Permission	South: Road Width - 2.40 MTR WIDE ROAD	
Nature of Development: New	East: CTS No. - SUNITA DEVI AND JAGDISH JI	
Location of Development Area: Old Area	West: Road Width - HOUSE OF R.N. GIRI AND 4.26 MTR WIDE ROAD	
AREA OF PLOT (Minimum)	(A)	343.06
NET AREA OF PLOT(Gross Plot Area - Deduction from Gross Plot area)	(A-Deductions)	343.06
Deduction for Balance Plot Area(from Gross Plot Area)		
Common Plot		46.27
Total		46.27
BALANCE AREA OF PLOT(Net Plot Area - Recreational/Amenity space)	(A-Deductions)	296.79
PLOT AREA FOR COVERAGE(Net Plot Area)	(A-Deductions)	343.06
Plot Area for FAR (Net Plot Area + RoadWidening Area)	(A-Deductions)	343.06
COVERAGE CHECK		
Permissible Coverage area (60.00 %)		205.84
Proposed Coverage Area (43.24 %)		148.33
Total Prop. Coverage Area (43.24 %)		148.33
Balance coverage area (16.76 %)		57.51
FAR CHECK		
Perm. FAR Area (1.500)		514.59
Total Perm. FAR area		514.59
Residential FAR		296.66
Proposed FAR Area		296.66
Total Proposed FAR Area		296.66
Consumed FAR (Factor)		0.86
Balance FAR Area		217.93
BUILT UP AREA CHECK		
Total Proposed BuiltUp Area		296.66
ARCHITECT (Regd)		AMRIT KUMAR MAHATO
ENGINEER (Regd)		
SUPERVISOR (Regd)		
OWNER (Regd)		KAMLA KANT MISHRA
DEVELOPMENT AUTHORITY		LOCAL BODY

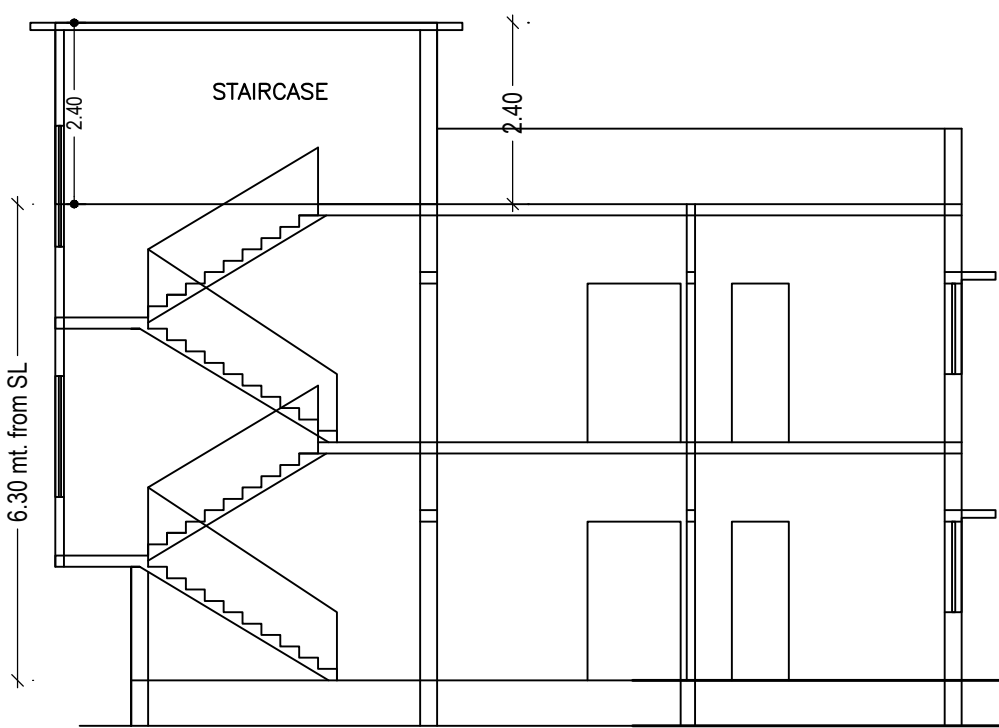

SECTION ON X-X'

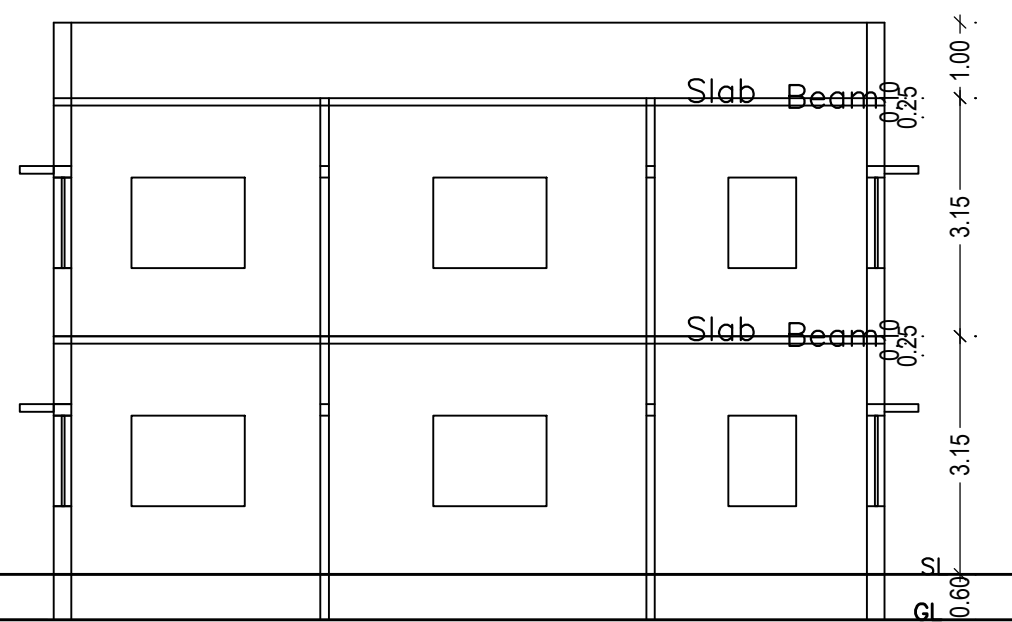

SECTION ON Y-Y'

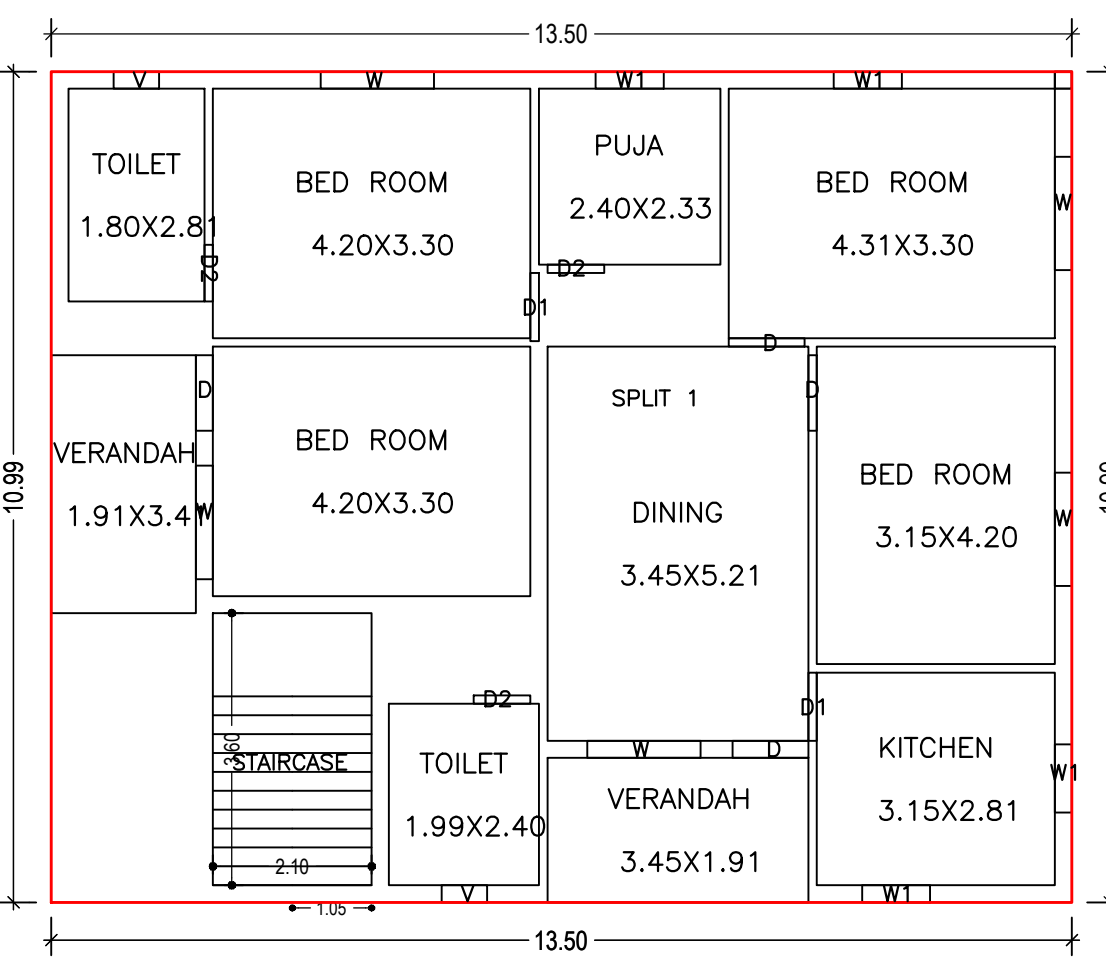
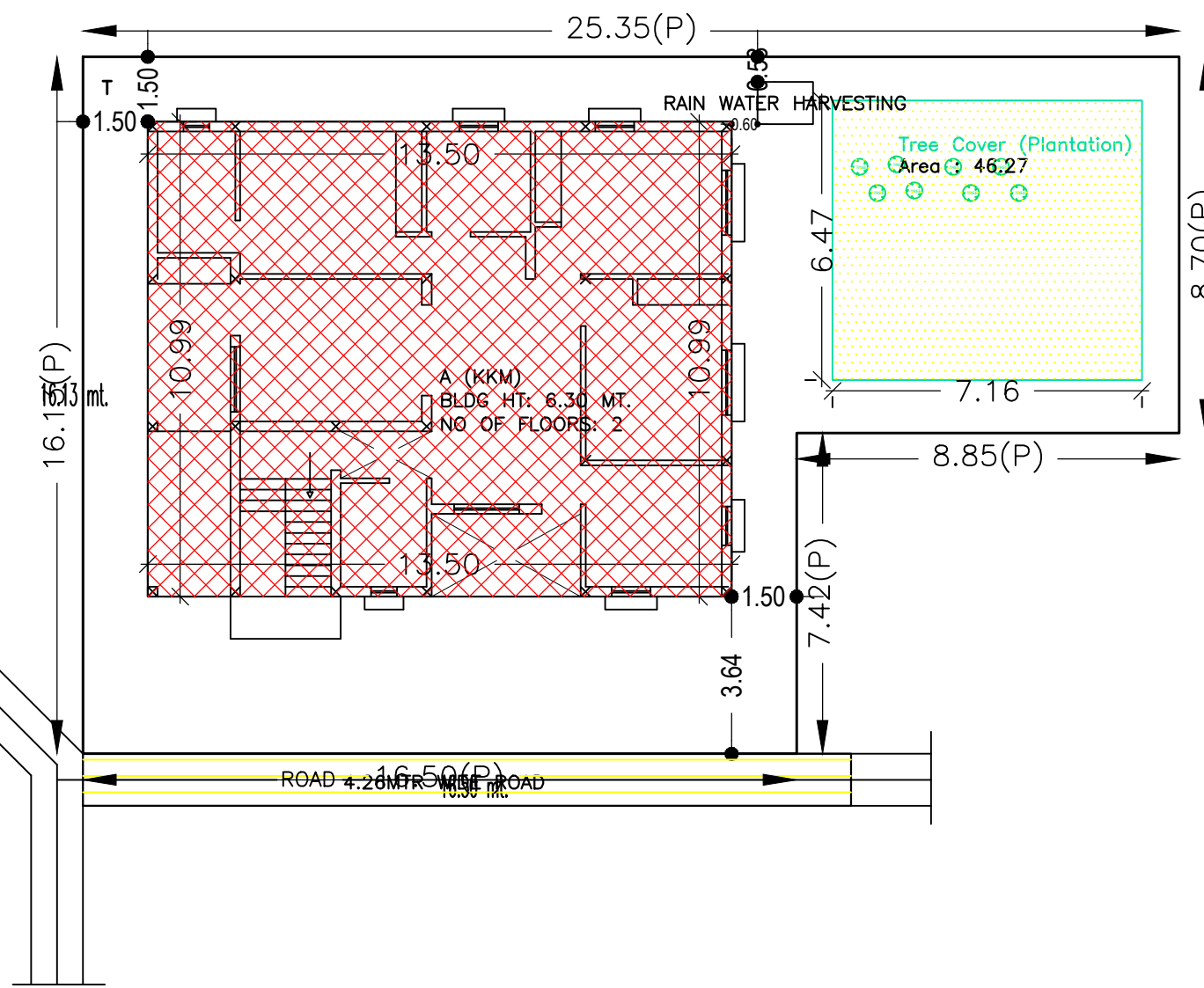

GROUND FLOOR PLAN (Proposed) (SCALE 1:100)

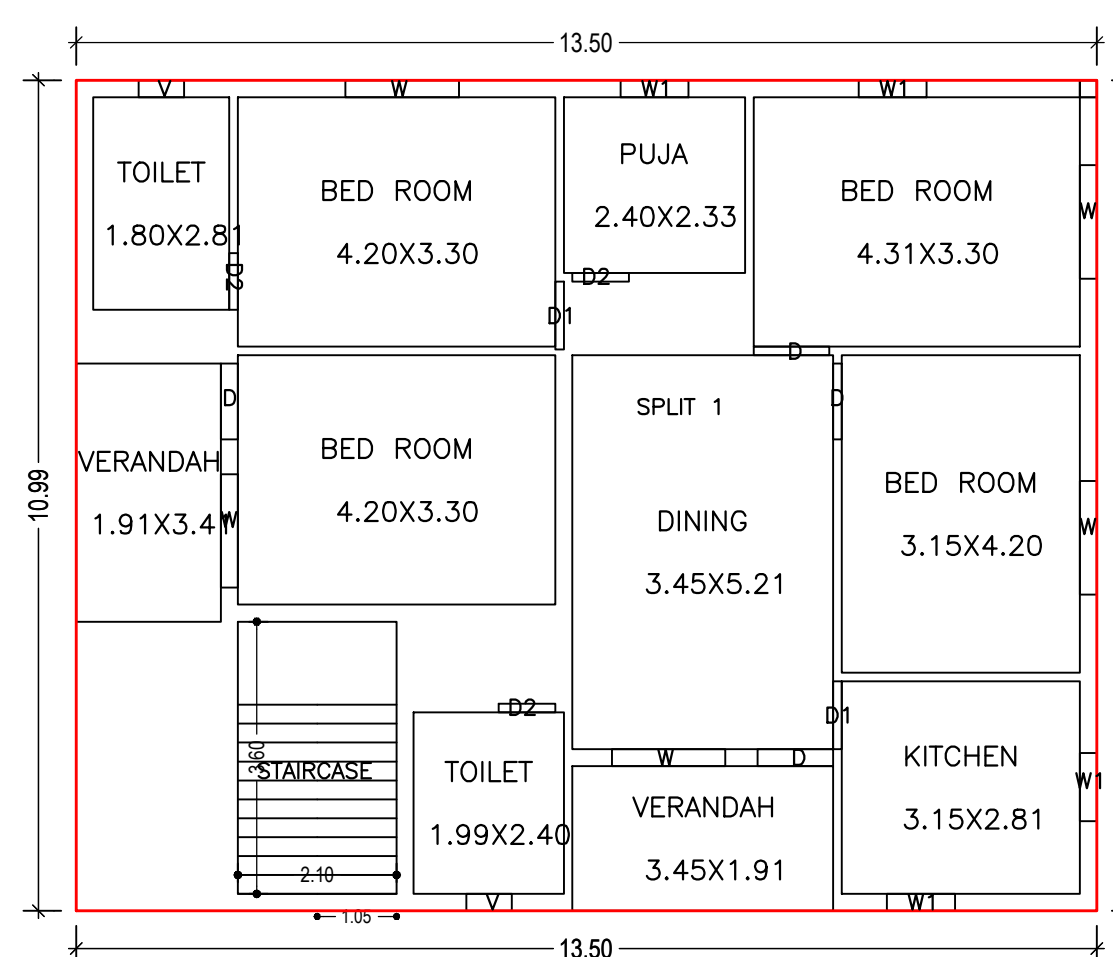

FIRST FLOOR PLAN (Proposed) (SCALE 1:100)

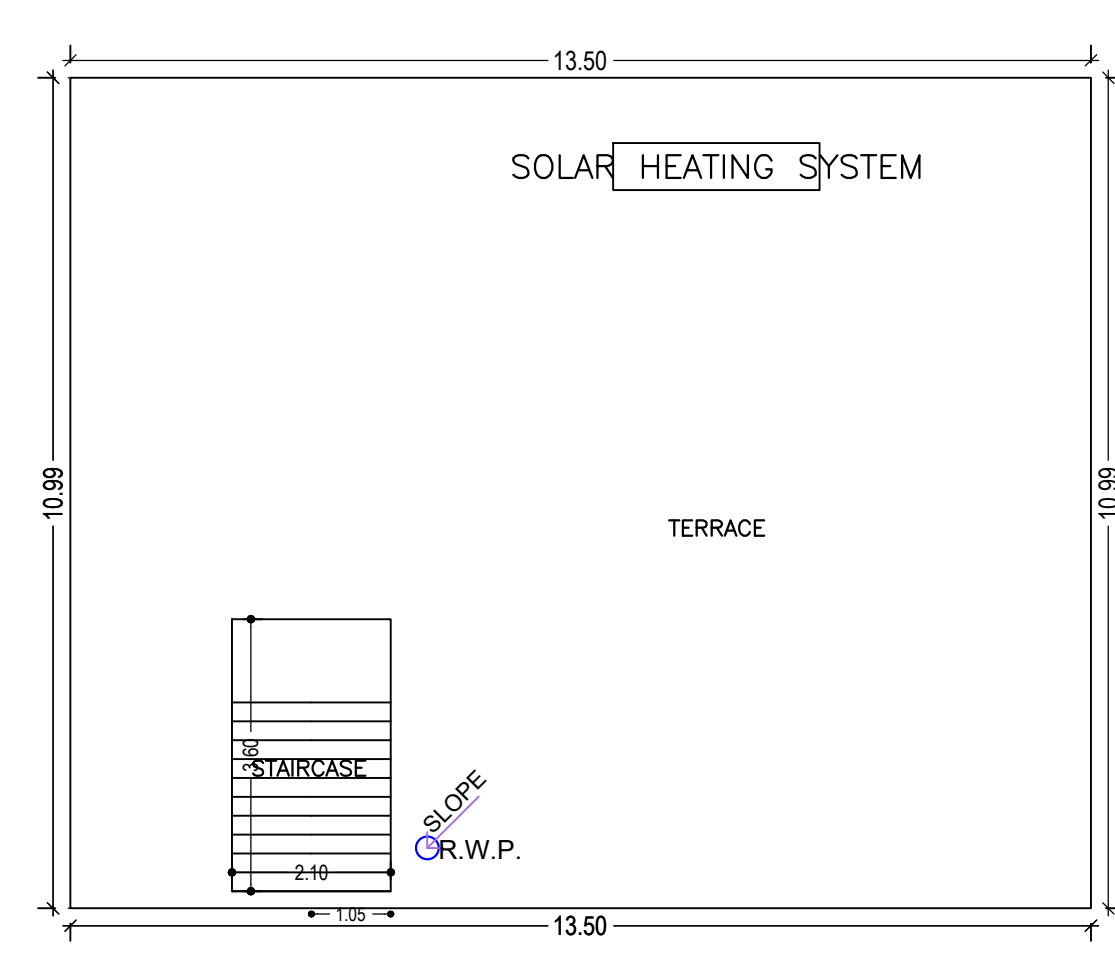

TERRACE FLOOR PLAN (SCALE 1:100)

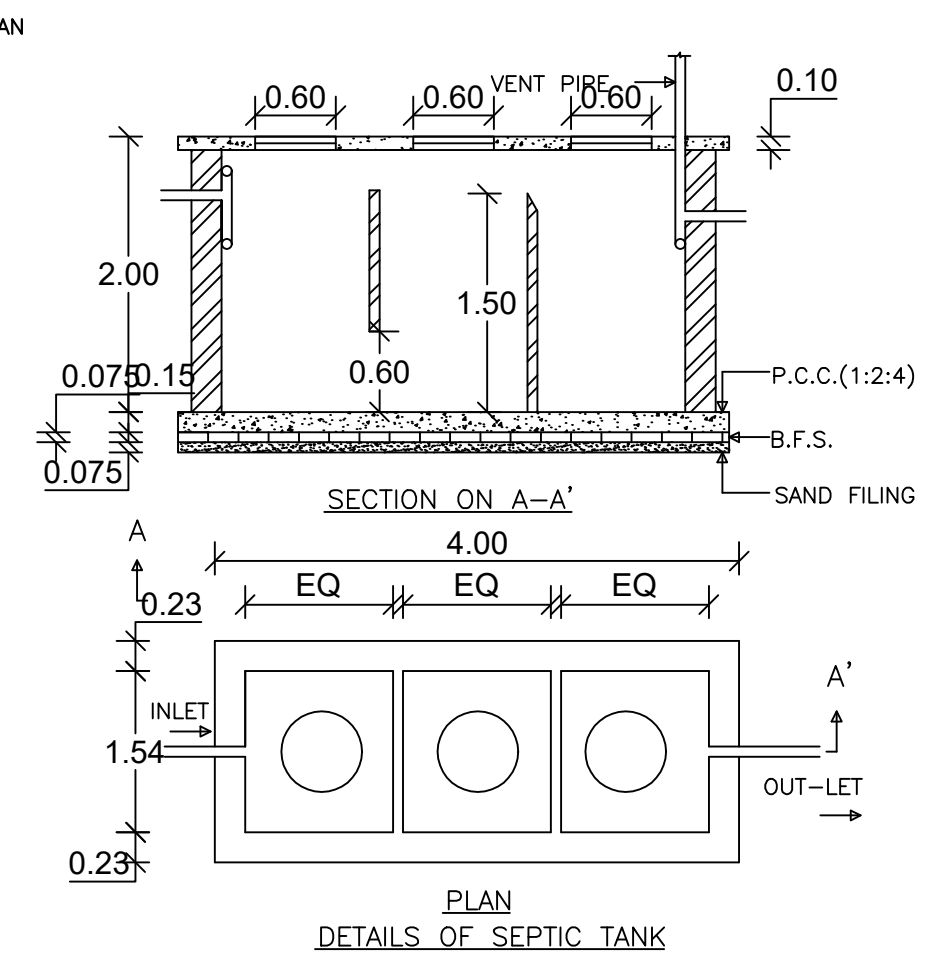

DETAILS OF SEPTIC TANK

Buildingwise Floor FAR Details

Floor Name	Building Name A (KKM)		Total	
	Proposed Built Up Area (Sq.mt.)	Proposed FAR Area (Sq.mt.)	Total Proposed Built Up Area (Sq.mt.)	Total FAR Area (Sq.mt.)
Ground Floor	148.33	148.33	148.33	148.33
First Floor	148.33	148.33	148.33	148.33
Terrace Floor	0.00	0.00	0.00	0.00
Total :	296.66	296.66	296.66	296.66

SCHEDULE OF DOOR:

BUILDING NAME	NAME	LENGTH	HEIGHT	NOS
A (KKM)	D2	0.75	2.10	06
A (KKM)	D1	0.90	2.10	04
A (KKM)	D	1.00	2.10	08

SCHEDULE OF WINDOW/VENTILATION:

BUILDING NAME	NAME	LENGTH	HEIGHT	NOS
A (KKM)	V	0.50	1.20	04
A (KKM)	W1	0.90	1.20	08
A (KKM)	W	1.50	1.20	10

Building :A (KKM)

Floor Name	Total Built Up Area (Sq.mt.)	Proposed FAR Area (Sq.mt.) Resi.	Total FAR Area (Sq.mt.)	Total Consumed Additional FAR Area (Sq.mt.)	Tnmt (No.)
Ground Floor	148.33	148.33	148.33	148.33	01
First Floor	148.33	148.33	148.33	148.33	00
Terrace Floor	0.00	0.00	0.00	0.00	00
Total :	296.66	296.66	296.66	296.66	01
Total Number of Same Buildings :	1				
Total :	296.66	296.66	296.66	296.66	01

UnitBUA Table for Building :A (KKM)

FLOOR	Name	UnitBUA Type	UnitBUA Area	Carpet Area	No. of Rooms	No. of Tenement
GROUND FLOOR PLAN	SPLIT 1	FLAT	296.66	296.56	11	1
FIRST FLOOR PLAN	SPLIT 1	FLAT	0.00	0.00	11	0
Total:	-	-	296.66	296.56	22	1

FAR & Tenement Details (Table 4c-1)

Building	No. of Same Bldg	Total Built Up Area (Sq.mt.)	Proposed FAR Area (Sq.mt.) Resi.	Total FAR Area (Sq.mt.)	Total Consumed Additional FAR Area (Sq.mt.)	Tnmt (No.)
A (KKM)	1	296.66	296.66	296.66	296.66	01
Grand Total :	1	296.66	296.66	296.66	296.66	01

Building USE/SUBUSE Details

Building Name	Building Use	Building SubUse	Building Structure
A (KKM)	Residential	Bungalow/ Dwelling / Non Apartment	Non-Highrise

COLOR INDEX

PLOT BOUNDARY	Black
ABUTTING ROAD	Red
PROPOSED CONSTRUCTION	Green
COMMON PLOT	Blue
ROAD WIDENING AREA	Yellow
EXISTING (To be retained)	Light Blue
EXISTING (To be demolished)	Light Yellow

LTP NAME AND SIGNATURE

AMRIT KUMAR MAHATO
CMC/DFTM/0004/2019

STRUCTURAL ENG'S NAME AND SIGNATURE

BUILDER NAME AND SIGNATURE

DIGITAL SIGNATURE