

Proposal Basic Information

Proposal File No.	CMC/BP/0127/W02/2022
Owner Name	Birendra Kumar Singh
Khata No	172
Plot No	775
Village Name	Chas
Use	Residential
SubUse	Bungalow/ Dwelling / Non Apartment

AREA STATEMENT CHAS MUNICIPAL CORPORATION

VERSION NO: 1.0.62  
VERSION DATE: 16/10/2020

PROJECT DETAIL:

Region: JHARKHAND URBAN	Plot Use: Residential
LOCAL BODIES	Plot SubUse: Bungalow/ Dwelling / Non Apartment
District: BOKARO	PlotNearbyReligiousStructure: NA
Authority: CHAS MUNICIPAL CORPORATION	
Inward_No: CMC/BP/0127/W02/2022	Plot/SubPlot No: 775
Application Type: General Proposal	North: Plot No. - 775
Project Type: Building Permission	South: Road Width - 9.14
Nature of Development: New	East: Road Width - 6.0
Location of Development Area: Old Area	West: Plot No. - 775

AREA DETAILS:

AREA OF PLOT (Minimum)	(A)	SQ. MT.
NET AREA OF PLOT(Gross Plot Area - Deduction from Gross Plot area)	(A-Deductions)	382.31
Deduction for Balance Plot Area(from Gross Plot Area)		
Common Plot		57.34
Total		57.34
BALANCE AREA OF PLOT(Net Plot Area - Recreational/Amenity space)	(A-Deductions)	324.97
PLOT AREA FOR COVERAGE(Net Plot Area)	(A-Deductions)	382.31
Plot Area for FAR (Net Plot Area + Road Widening Area)	(A-Deductions)	382.31

COVERAGE CHECK

Permissible Coverage area (60.00 %)	229.39
Proposed Coverage Area (32.02 %)	122.40
Total Prop. Coverage Area (32.02 %)	122.40
Balance coverage area (27.99 %)	106.99

FAR CHECK

Perm. FAR Area (2.50)	955.78
Total Perm. FAR area	955.78
Residential FAR	244.80
Proposed FAR Area	244.80
Total Proposed FAR Area	244.80
Consumed FAR (Factor)	0.64
Balance FAR Area	710.98

BUILT UP AREA CHECK

Total Proposed BuiltUp Area	244.80
-----------------------------	--------

ARCHITECT (Regd) Rupendra Kumar Singh  
ENGINEER (Regd)  
SUPERVISOR (Regd) Birendra Kumar Singh  
OWNER (Regd)

DEVELOPMENT AUTHORITY LOCAL BODY

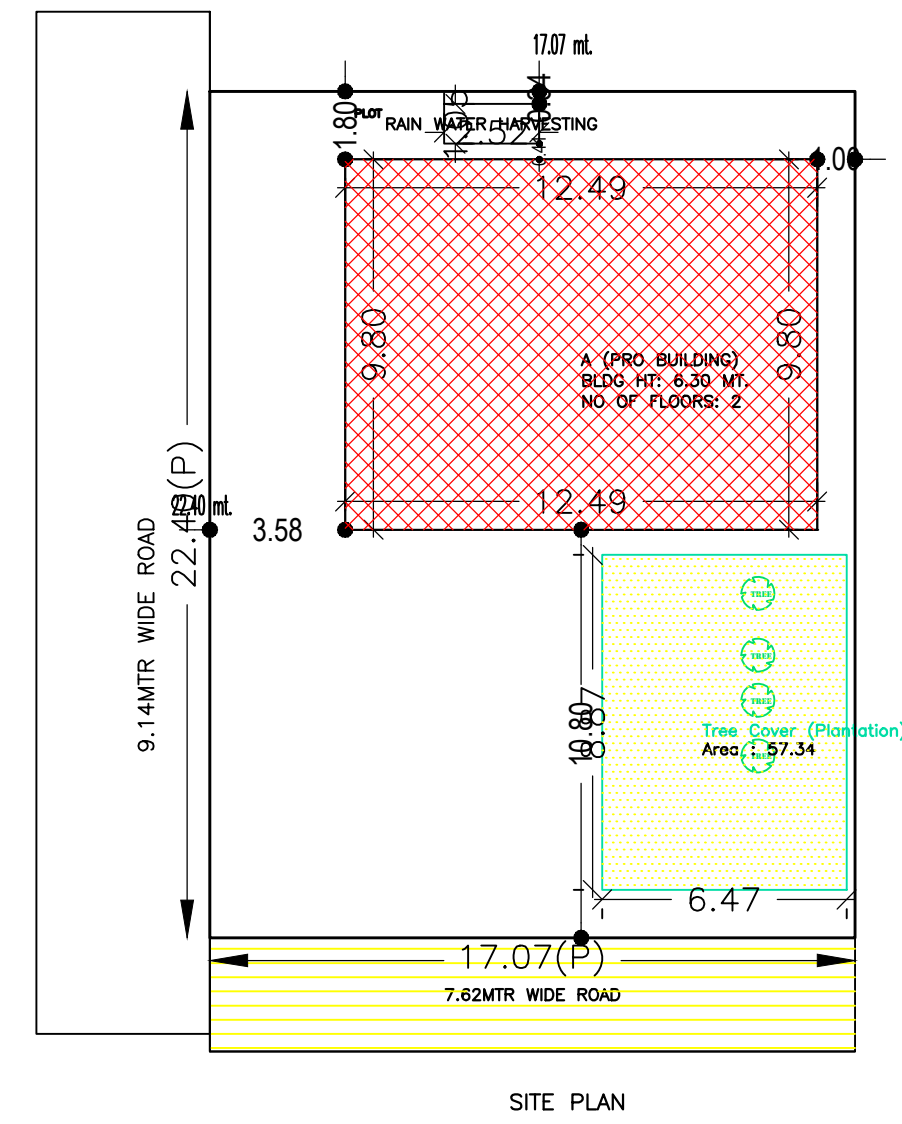
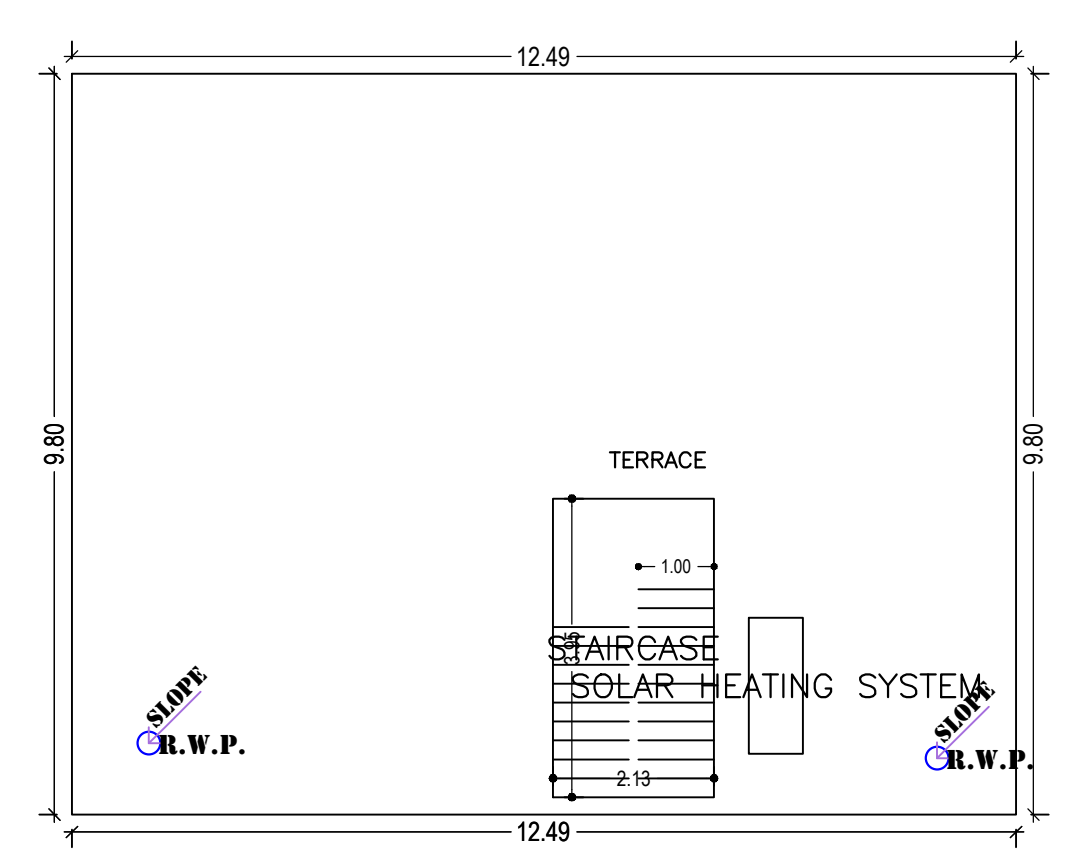
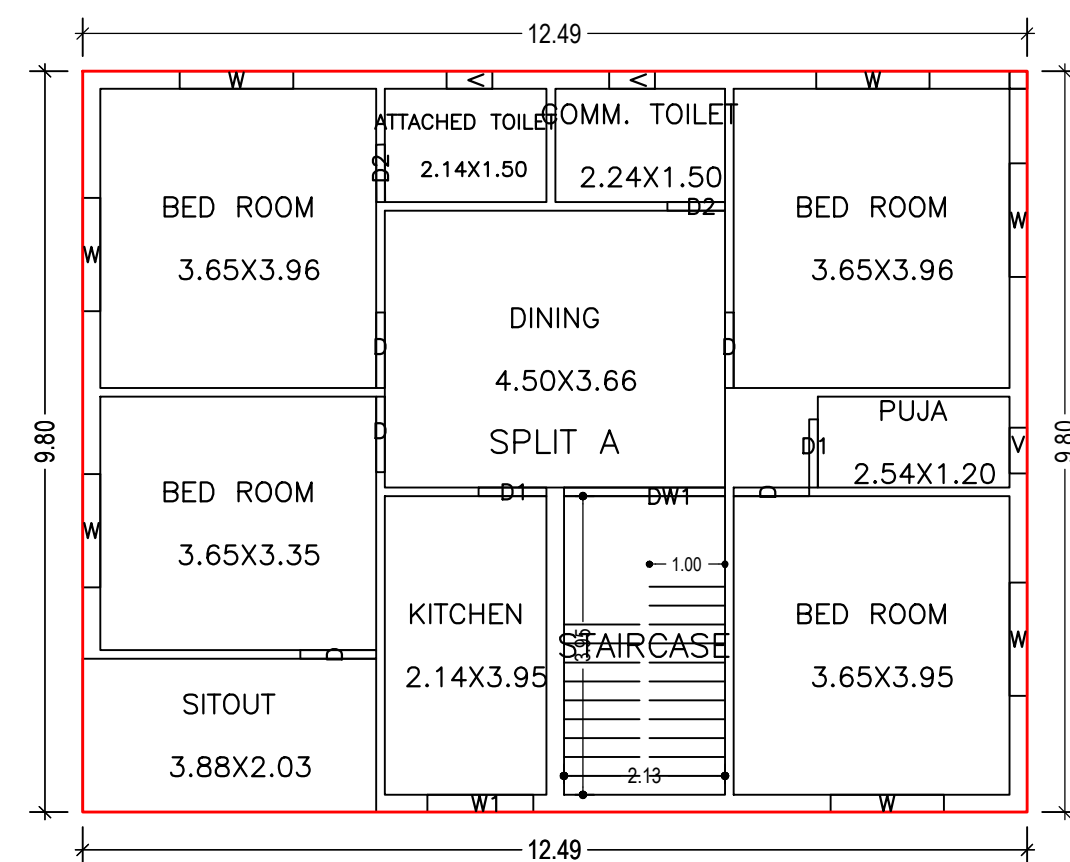
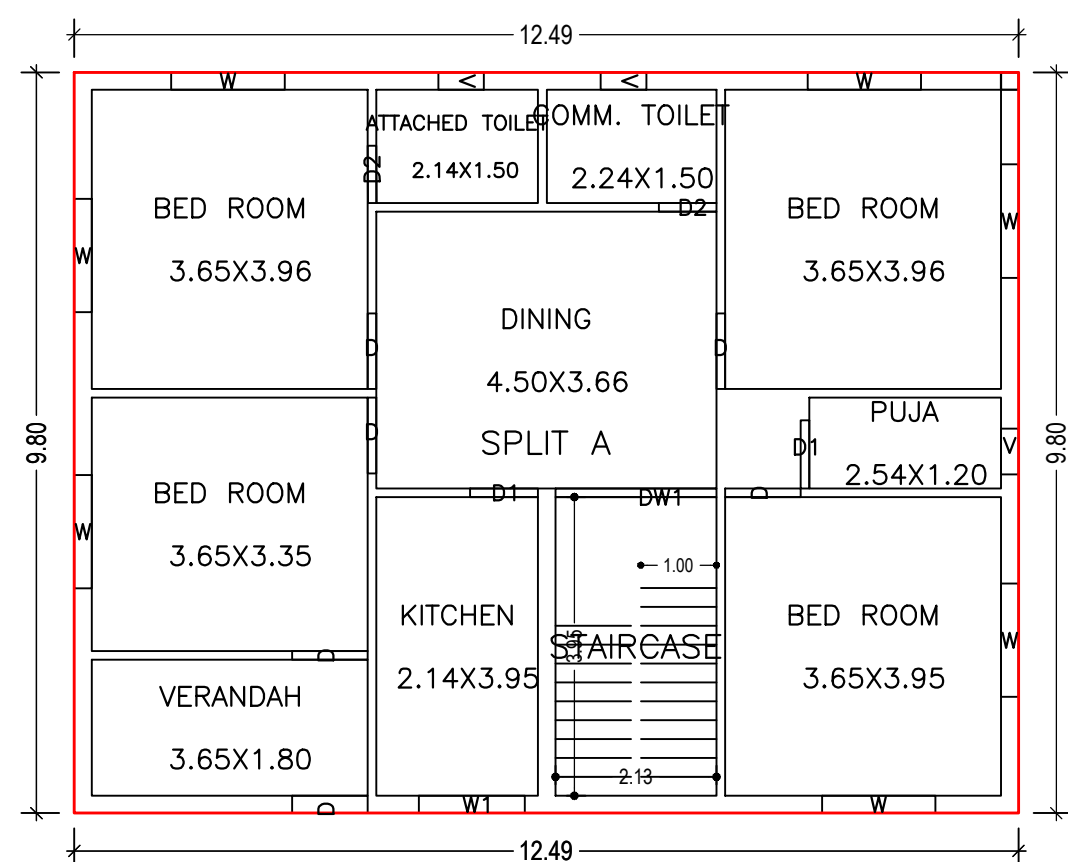
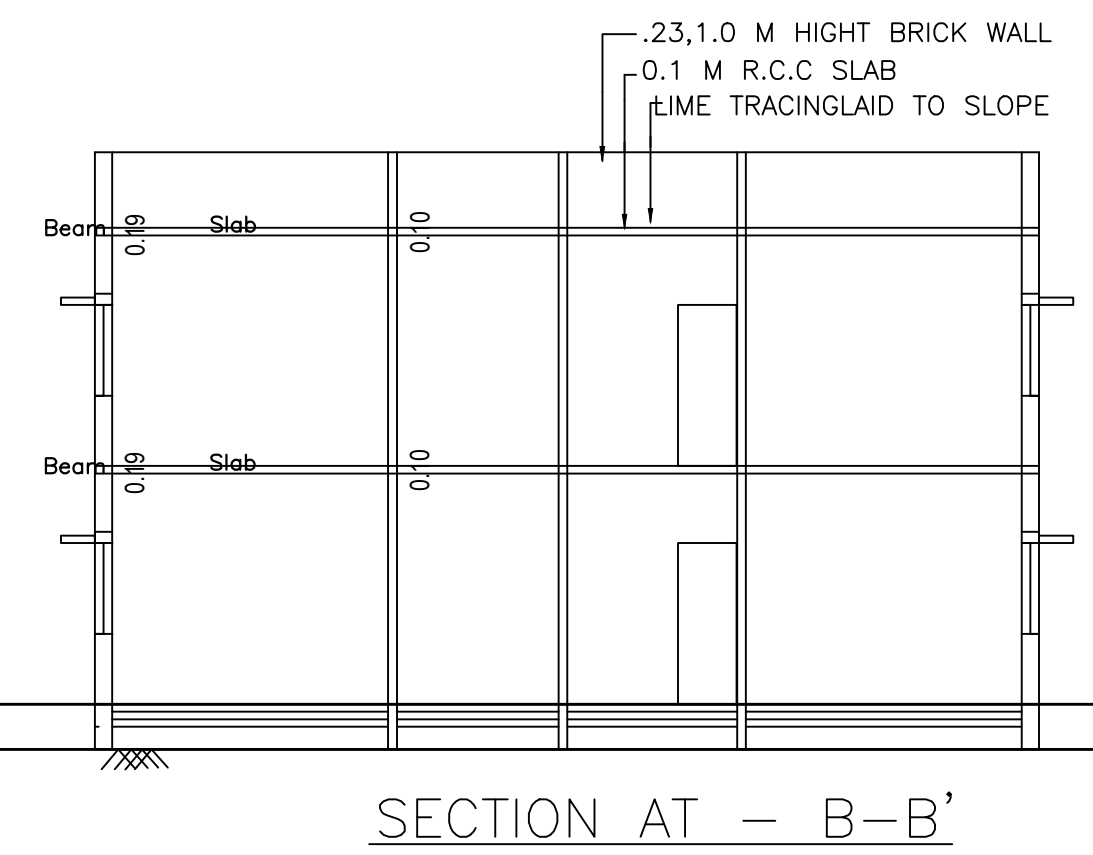
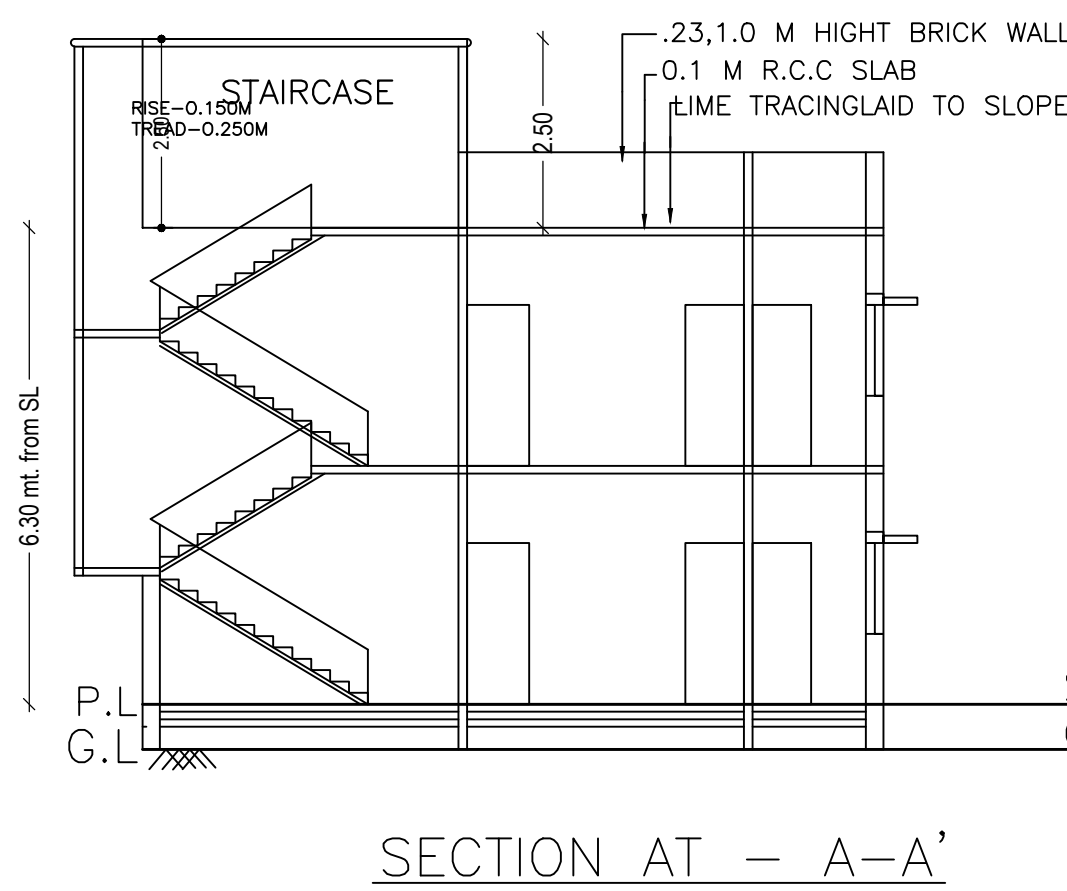
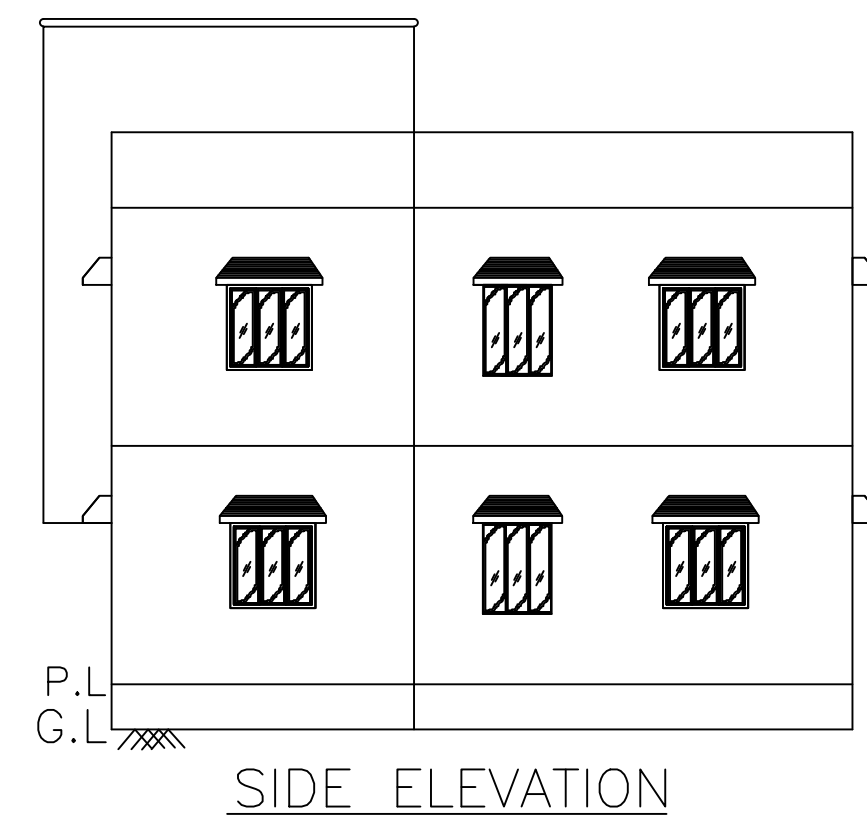

Building :A (PRO BUILDING)

Floor Name	Total Built Up Area (Sq.mt.)	Proposed FAR Area (Sq.mt.)	Total FAR Area (Sq.mt.)	Total Consumed Additional FAR Area (Sq.mt.)	Tnmt (No.)
Ground Floor	122.40	122.40	122.40	122.40	01
First Floor	122.40	122.40	122.40	122.40	00
Terrace Floor	0.00	0.00	0.00	0.00	00
Total :	244.80	244.80	244.80	244.80	01
Total Number of Same Buildings	1				
Total :	244.80	244.80	244.80	244.80	01

SCHEDULE OF DOOR:

BUILDING NAME	NAME	LENGTH	HEIGHT	NOS
A (PRO BUILDING)	D2	0.76	2.10	04
A (PRO BUILDING)	D1	0.90	2.10	04
A (PRO BUILDING)	D	1.00	2.10	11

SCHEDULE OF WINDOW/VENTILATION:

BUILDING NAME	NAME	LENGTH	HEIGHT	NOS
A (PRO BUILDING)	V	0.61	1.20	06
A (PRO BUILDING)	W1	1.40	1.20	02
A (PRO BUILDING)	W	1.50	1.20	14
A (PRO BUILDING)	DW1	2.13	1.20	02

Buildingwise Floor FAR Details

Floor Name	Building Name A (PRO BUILDING)		Total	
	Proposed Built Up Area (Sq.mt.)	Proposed FAR Area (Sq.mt.)	Total Proposed Built Up Area (Sq.mt.)	Total FAR Area (Sq.mt.)
Ground Floor	122.40	122.40	122.40	122.40
First Floor	122.40	122.40	122.40	122.40
Terrace Floor	0.00	0.00	0.00	0.00
Total :	244.80	244.80	244.80	244.80

Building USE/SUBUSE Details

Building Name	Building Use	Building SubUse	Building Structure
A (PRO BUILDING)	Residential	Bungalow/ Dwelling / Non Apartment	Non-Highrise

UnitBUA Table for Building :A (PRO BUILDING)

FLOOR	Name	UnitBUA Type	UnitBUA Area	Carpet Area	No. of Rooms	No. of Tenement
FIRST FLOOR PLAN	SPLIT A	FLAT	0.00	0.00	10	0
GROUND FLOOR PLAN	SPLIT A	FLAT	244.80	244.70	10	1
Total:	-	-	244.80	244.70	20	1

FAR & Tenement Details (Table 4c-1)

Building	No. of Same Bldg	Total Built Up Area (Sq.mt.)	Proposed FAR Area (Sq.mt.)	Total FAR Area (Sq.mt.)	Total Consumed Additional FAR Area (Sq.mt.)	Tnmt (No.)
A (PRO BUILDING)	1	244.80	244.80	244.80	244.80	01
Grand Total :	1	244.80	244.80	244.80	244.80	01

COLOR INDEX

PLOT BOUNDARY	Black
ABUTTING ROAD	Red
PROPOSED CONSTRUCTION	Green
COMMON PLOT	Yellow
ROAD WIDENING AREA	Blue
EXISTING (To be retained)	White
EXISTING (To be demolished)	Grey

LTP NAME AND SIGNATURE	STRUCTURAL ENG'S NAME AND SIGNATURE	BUILDER NAME AND SIGNATURE	DIGITAL SIGNATURE
Rupendra Kumar Singh CMC/ENG/0002/2022			