

Proposal Basic Information

Proposal File No.	CMC/BP/0152/W30/2022
Owner Name	MANJU DEVI
Khata No	27, NEW KHATA NO.- 171
Plot No	23.26 NEW PLOT NO-81
Village Name	Bandhgora
Use	Residential
SubUse	Bungalow/ Dwelling / Non Apartment

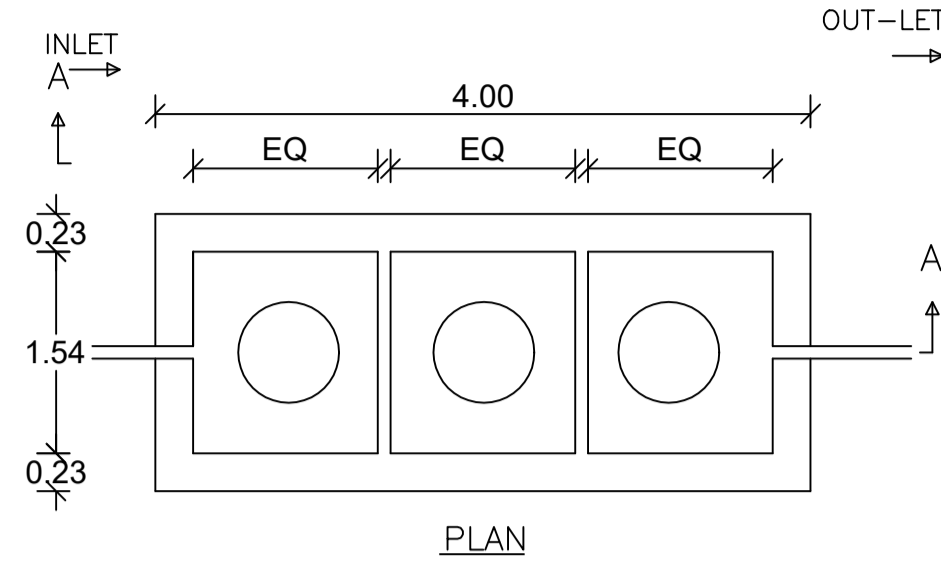

DETAILS OF SEPTIC TANK

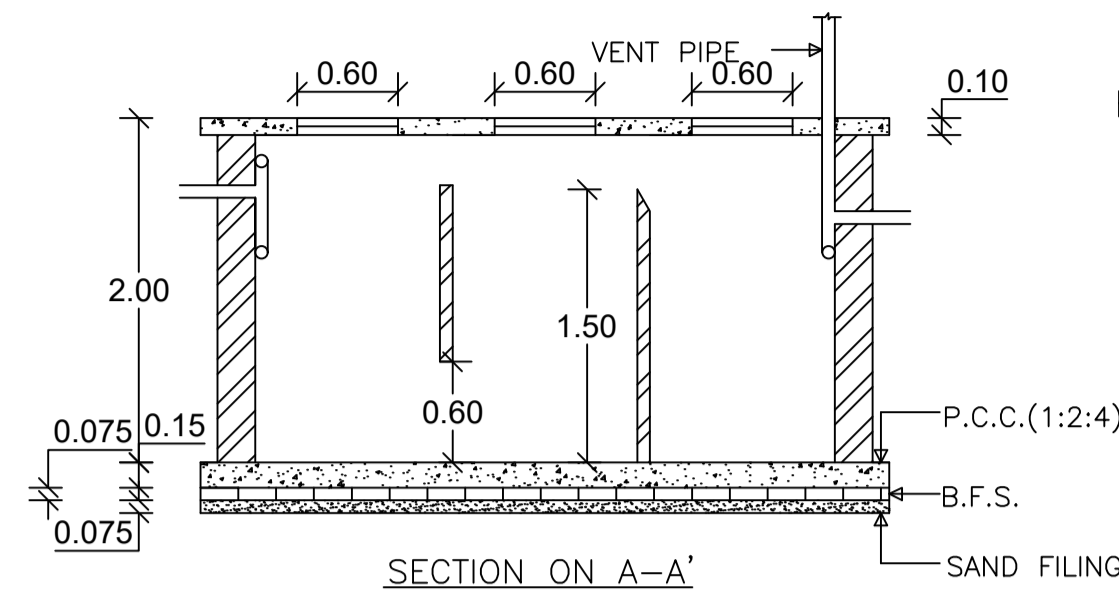

SECTION ON A-A'

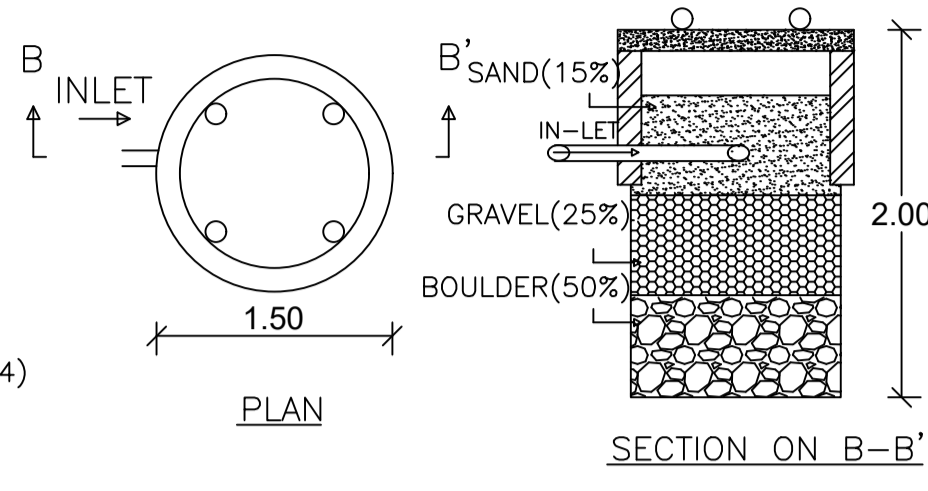

DETAILS OF WATER HARVESTING

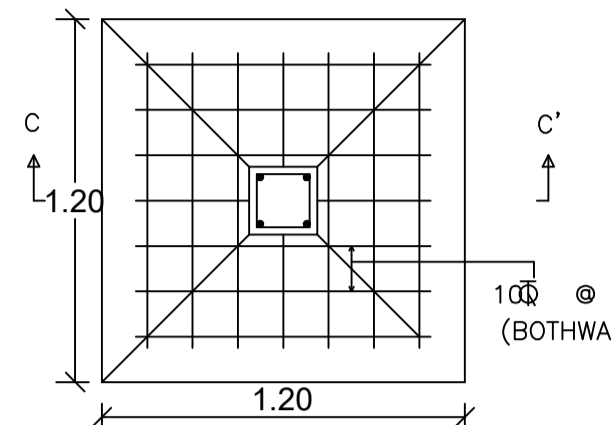

PLAN

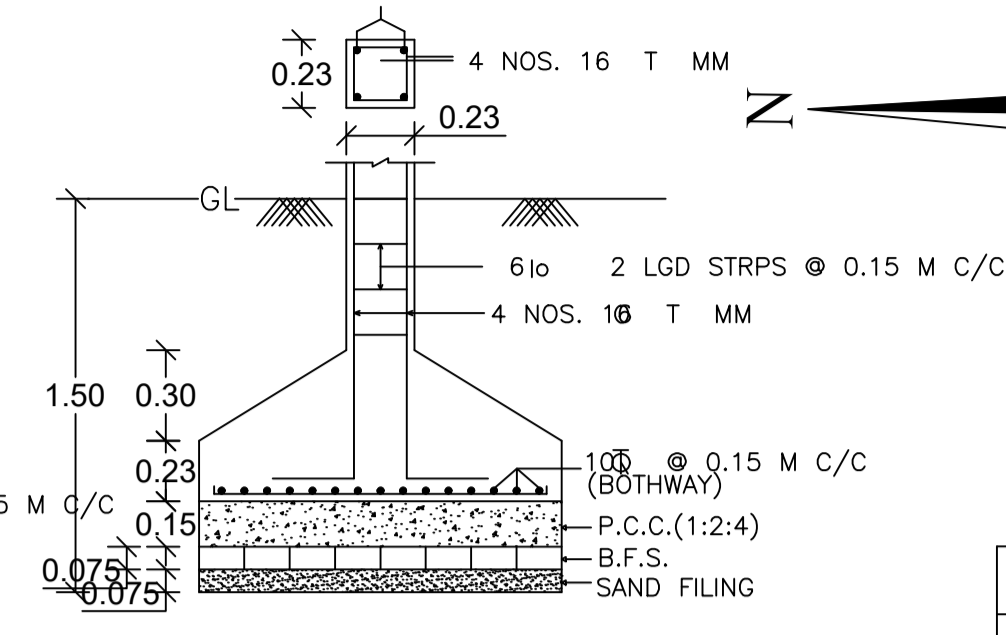

DETAILS OF FOUNDATION SECTION ON C-C'

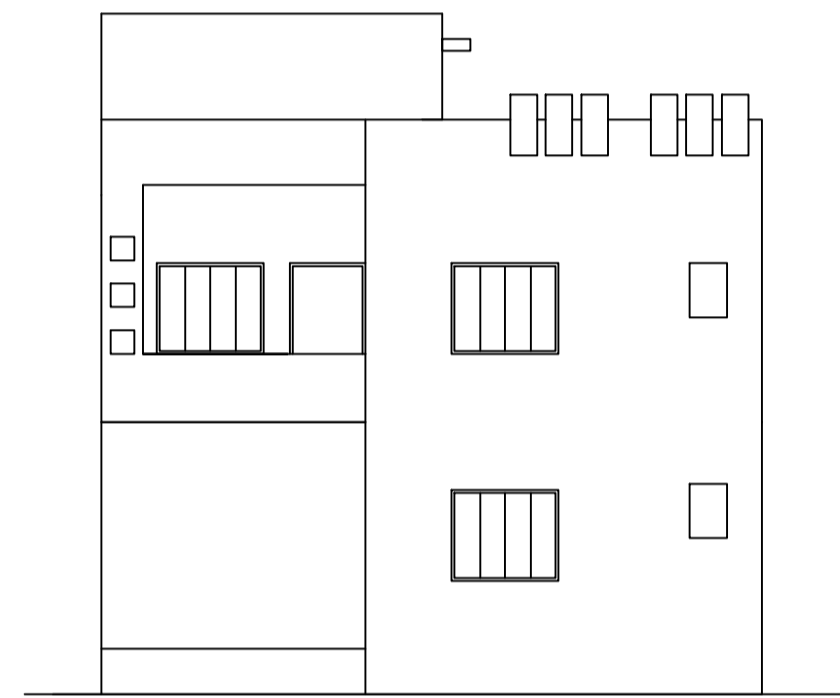
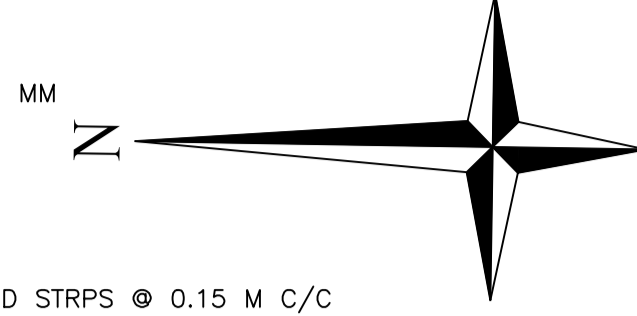

FRONT ELEVATION

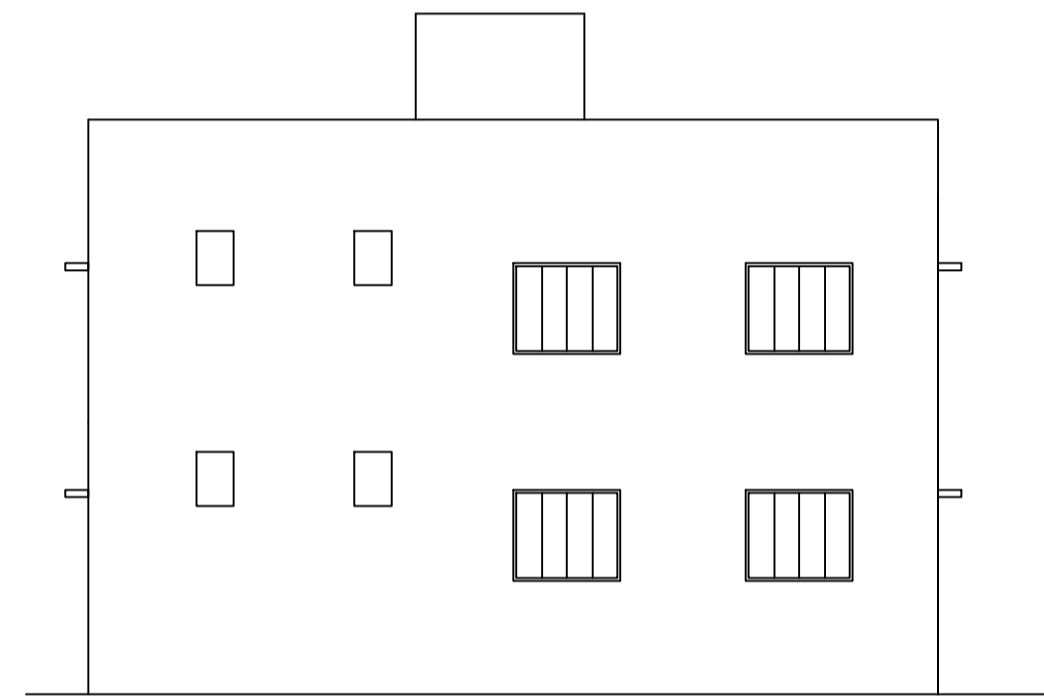

SIDE ELEVATION

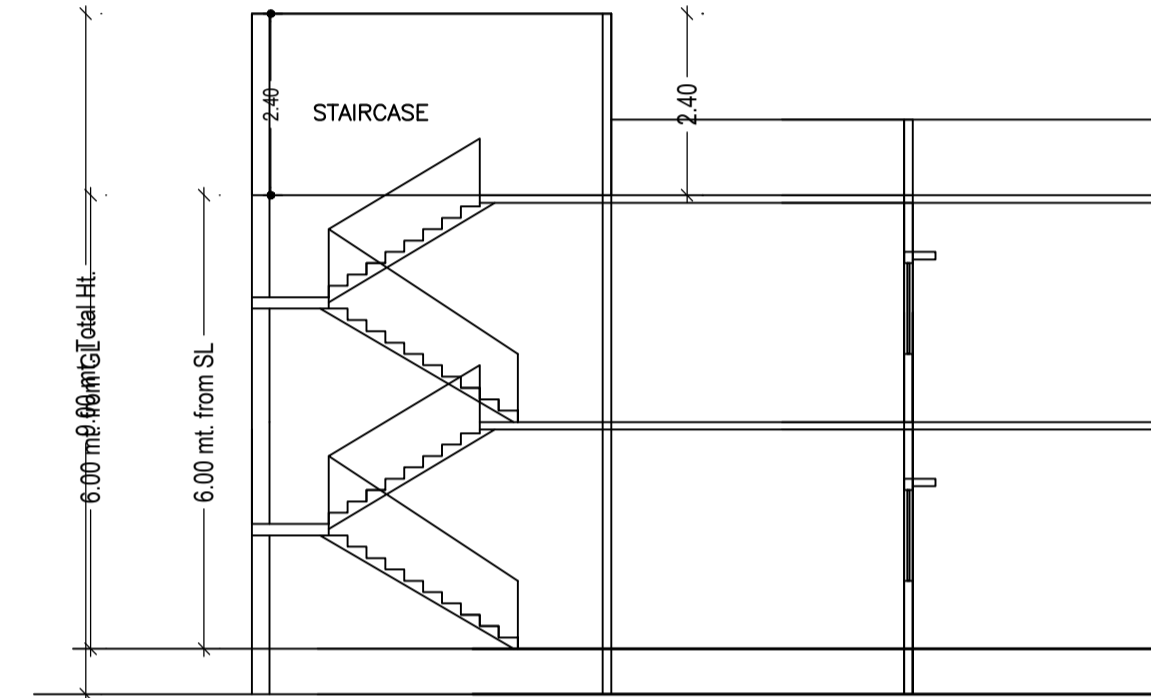

SECTION ON X-X

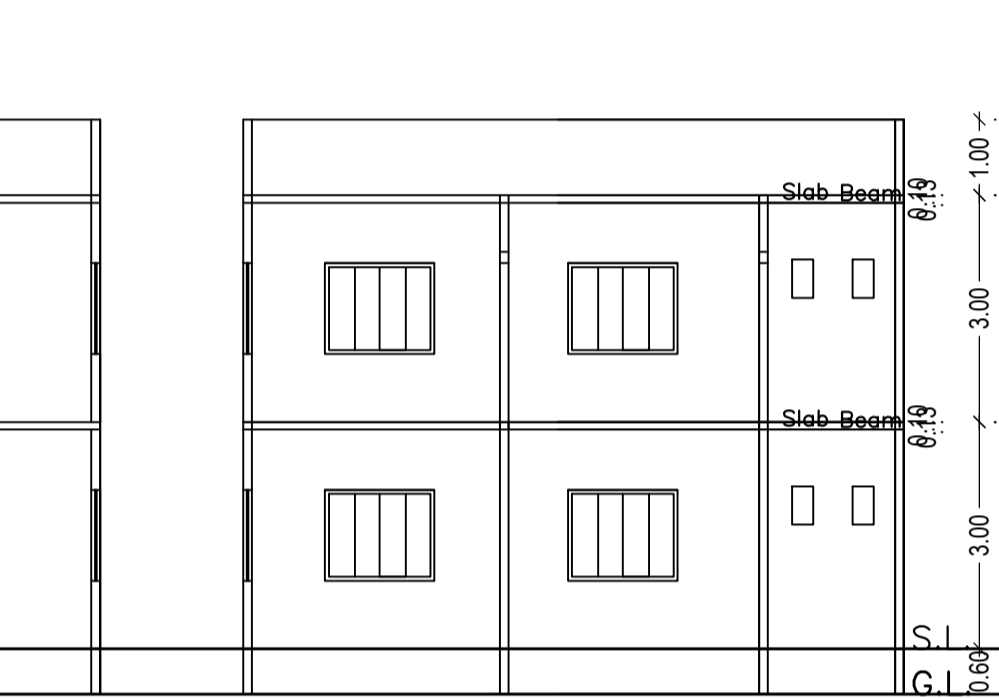

SECTION ON Y-Y

AREA STATEMENT CHAS MUNICIPAL CORPORATION	VERSION NO. : 1.0.62	VERSION DATE: 16/10/2020
PROJECT DETAIL:		
Region: JHARKHAND URBAN	Plot Use: Residential	
Local Bodies: Dist: BOKARO	Plot SubUse: Bungalow/ Dwelling / Non Apartment	
Authority: CHAS MUNICIPAL CORPORATION	PlotNearbyReligiousStructure: NA	
Inward No: CMC/BP/0152/W30/2022	Plot/SubPlot No: 23.26 NEW PLOT NO-81	
Application Type: General Proposal	North: Plot No. - PLOTING NO- 05	
Project Type: Building Permission	South: Plot No. - PLOTING NO- 03	
Nature of Development: New	East: Plot No. - PART OF REST PLOT NO- 26	
Location of Development Area: Old Area	West: Road Width - 4.57 M WIDE ROAD	
AREA DETAILS:		
AREA OF PLOT (Minimum)	(A)	SQ. MT. 146.91
NET AREA OF PLOT (Gross Plot Area - Deduction from Gross Plot Area)	(A-Deductions)	146.91
Deduction for Balance Plot Area (from Gross Plot Area)		
Common Plot		9.59
Total		9.59
BALANCE AREA OF PLOT (Net Plot Area - Recreational/Amenity space)	(A-Deductions)	137.33
PLOT AREA FOR COVERAGE (Net Plot Area)	(A-Deductions)	146.91
Plot Area for FAR (Net Plot Area + Road Widening Area)	(A-Deductions)	146.91
COVERAGE CHECK		
Permissible Coverage area (70.00 %)		102.84
Proposed Coverage Area (66.87 %)		98.24
Total Prop. Coverage Area (66.87 %)		98.24
Balance coverage area (3.13 %)		4.60
FAR CHECK		
Perm. FAR Area (1.50)		220.37
Total Perm. FAR area		220.37
Residential FAR		196.48
Proposed FAR Area		196.48
Total Proposed FAR Area		196.48
Consumed FAR (Factor)		1.34
Balance FAR Area		23.89
BUILT UP AREA CHECK		
Total Proposed BuiltUp Area		196.48
ARCHITECT (Regd)		AMRIT KUMAR MAHATO
ENGINEER (Regd)		
SUPERVISOR (Regd)		
OWNER (Regd)		MANJU DEVI
DEVELOPMENT AUTHORITY		LOCAL BODY

SCHEDULE OF DOOR:

BUILDING NAME	NAME	LENGTH	HEIGHT	NOS
A (MANJU)	D2	0.75	2.10	04
A (MANJU)	D1	0.90	2.10	05
A (MANJU)	D	1.00	2.10	10

SCHEDULE OF WINDOW/VENTILATION:

BUILDING NAME	NAME	LENGTH	HEIGHT	NOS
A (MANJU)	V	0.60	1.20	04
A (MANJU)	W1	0.90	1.20	03
A (MANJU)	W	1.20	1.20	13

Buildingwise Floor FAR Details

Floor Name	Building Name		Total	
	Proposed Built Up Area (Sq.mt.)	Proposed FAR Area (Sq.mt.)	Total Proposed Built Up Area (Sq.mt.)	Total FAR Area (Sq.mt.)
Ground Floor	98.24	98.24	98.24	98.24
First Floor	98.24	98.24	98.24	98.24
Terrace Floor	0.00	0.00	0.00	0.00
Total :	196.48	196.48	196.48	196.48

Building :A (MANJU)

Floor Name	Total Built Up Area (Sq.mt.)	Proposed FAR Area (Sq.mt.)		Total Consumed Additional FAR Area (Sq.mt.)	Trmt (No.)
		Resi.	Total FAR Area (Sq.mt.)		
Ground Floor	98.24	98.24	98.24	98.24	01
First Floor	98.24	98.24	98.24	98.24	00
Terrace Floor	0.00	0.00	0.00	0.00	00
Total :	196.48	196.48	196.48	196.48	01
Total Number of Same Buildings :	1				
Total :	196.48	196.48	196.48	196.48	01

Building USE/SUBUSE Details

Building Name	Building Use	Building SubUse	Building Structure
A (MANJU)	Residential	Bungalow/ Dwelling / Non Apartment	Non-Highrise

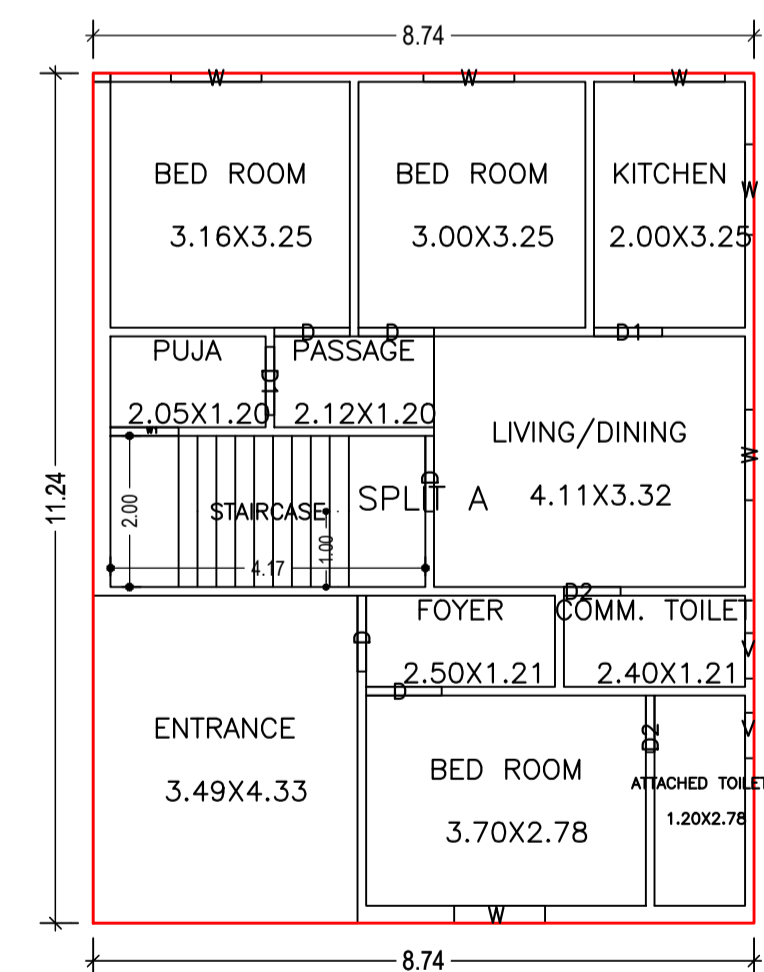

GROUND FLOOR PLAN (Proposed) (SCALE 1:100)

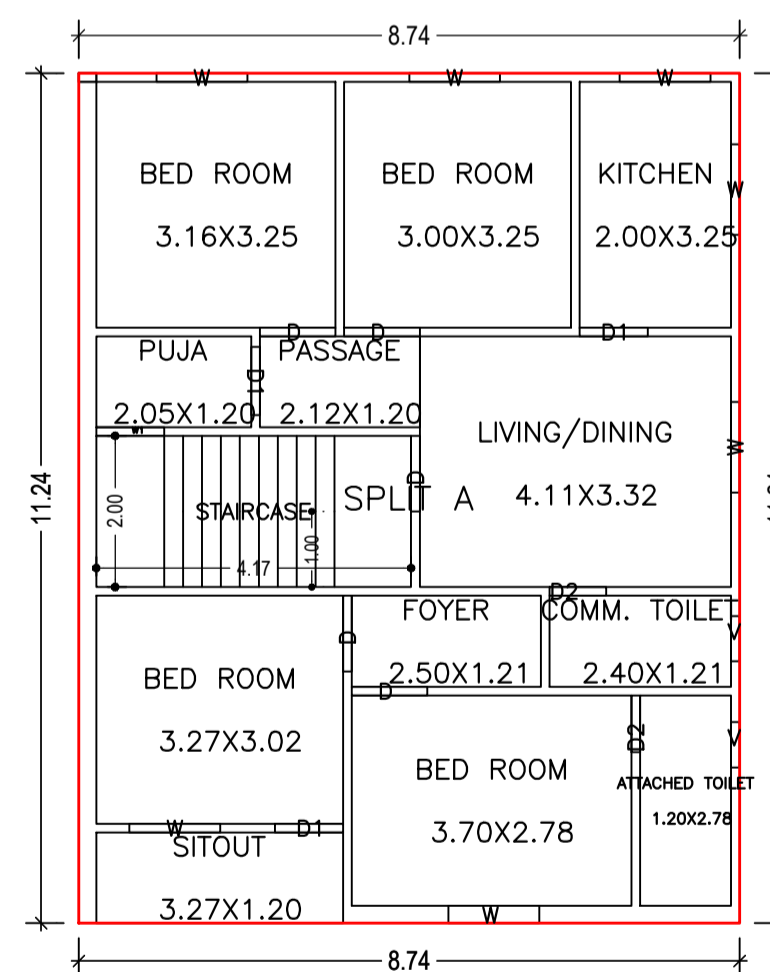

FIRST FLOOR PLAN (Proposed) (SCALE 1:100)

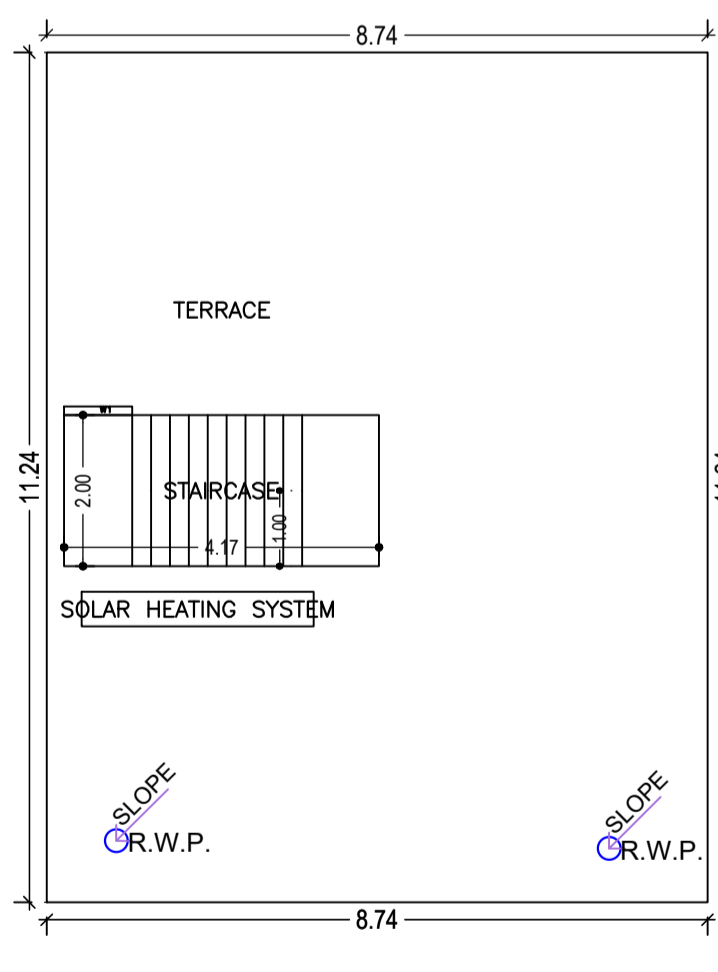

TERRACE FLOOR PLAN (SCALE 1:100)

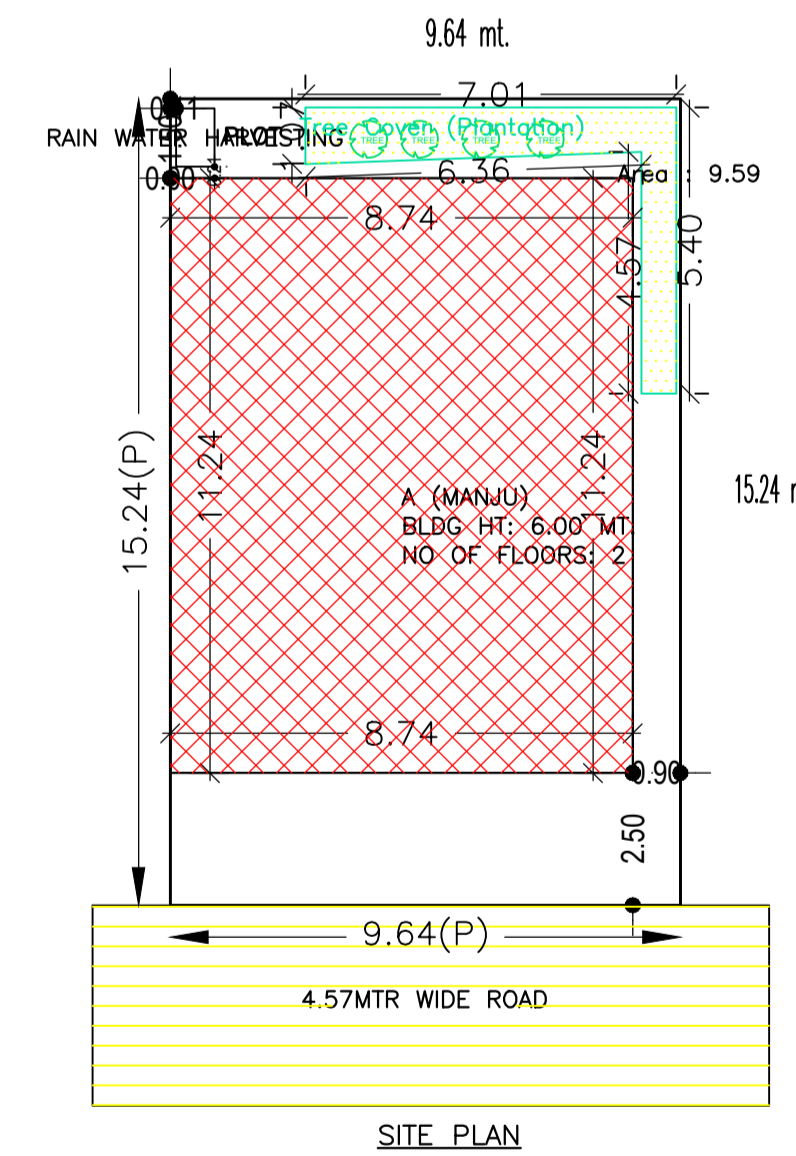

SITE PLAN

FAR & Tenement Details (Table 4c-1)

Building	No. of Same Bldg	Total Built Up Area (Sq.mt.)	Proposed FAR Area (Sq.mt.) Resi.	Total FAR Area (Sq.mt.)	Total Consumed Additional FAR Area (Sq.mt.)	Trmt (No.)
A (MANJU)	1	196.48	196.48	196.48	196.48	01
Grand Total :	1	196.48	196.48	196.48	196.48	01

UnitBUA Table for Building :A (MANJU)

FLOOR	Name	UnitBUA Type	UnitBUA Area	Carpet Area	No. of Rooms	No. of Tenement
GROUND FLOOR	SPLIT A	FLAT	196.48	196.42	11	1
FIRST FLOOR	SPLIT A	FLAT	0.00	0.00	12	0
PLAN	-	-	196.48	196.42	23	1

COLOR INDEX

- PLOT BOUNDARY
- ABUTTING ROAD
- PROPOSED CONSTRUCTION
- COMMON PLOT
- ROAD WIDENING AREA
- EXISTING (To be retained)
- EXISTING (To be demolished)

LTP NAME AND SIGNATURE

AMRIT KUMAR MAHATO
CMC/DFTM/0004/2019

STRUCTURAL ENG'S NAME AND SIGNATURE

BUILDER NAME AND SIGNATURE

DIGITAL SIGNATURE