

Proposal Basic Information	
Proposal File No.	CMC/BP/0283/W07/2022
Owner Name	ASHA DEVI
Khata No	375
Plot No	3347
Village Name	Chas
Use	Residential
SubUse	Bungalow/ Dwelling / Non Apartment

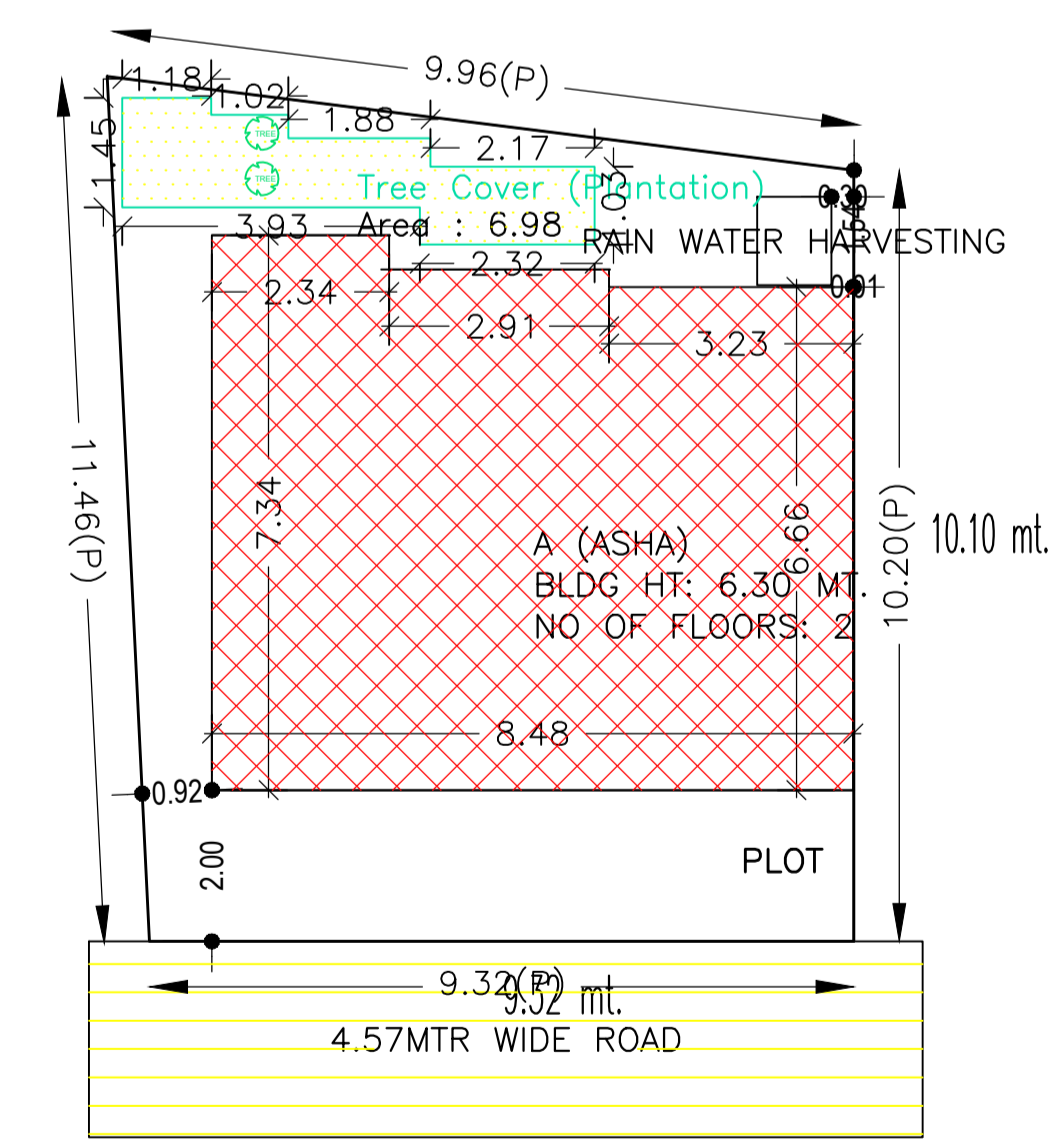
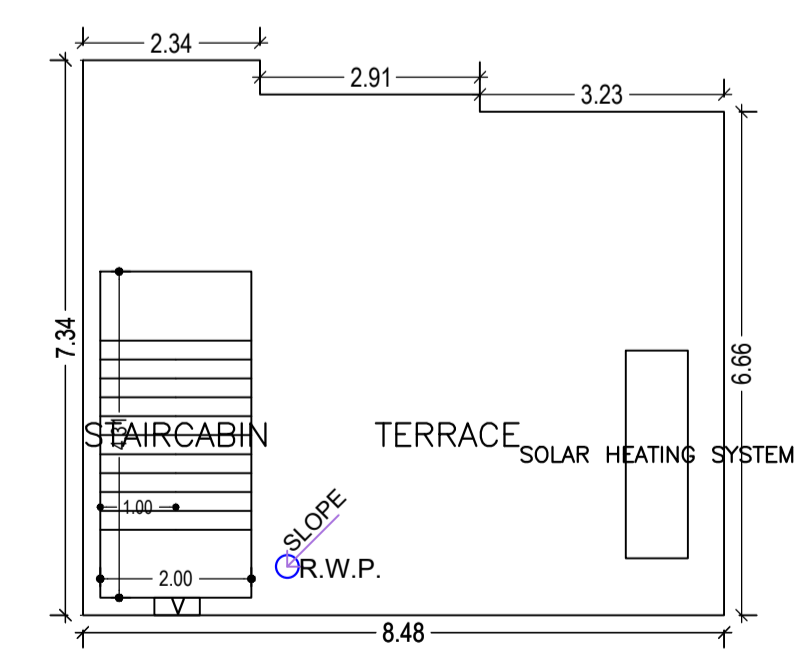
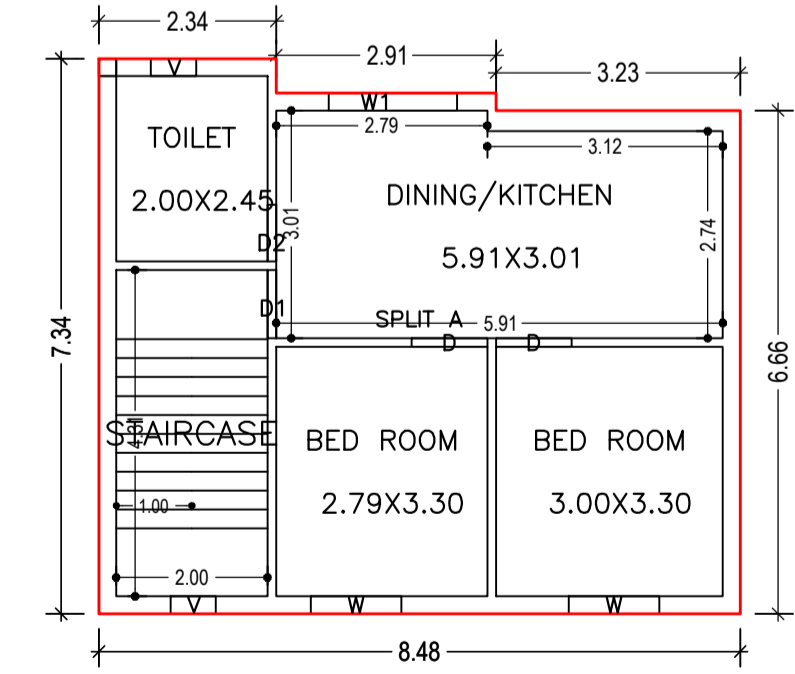
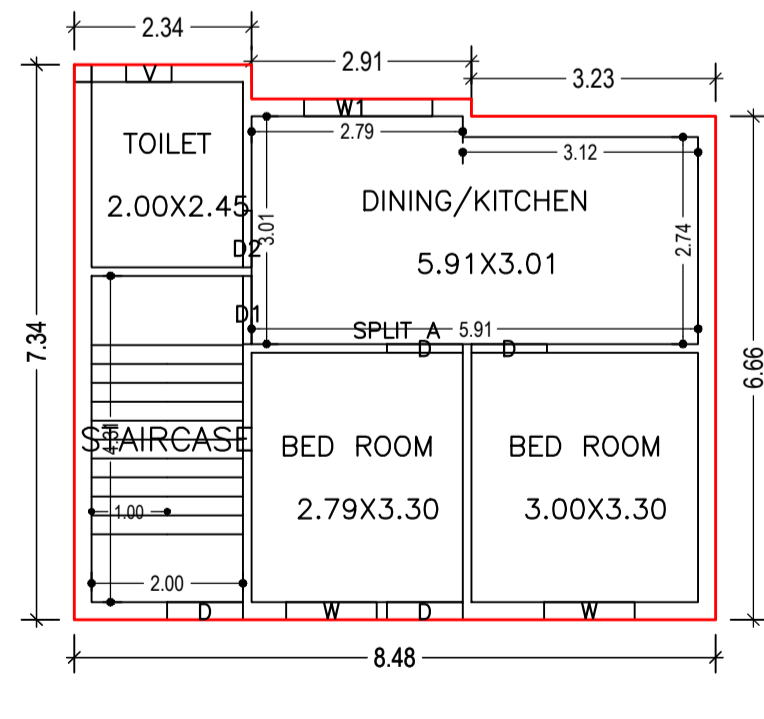
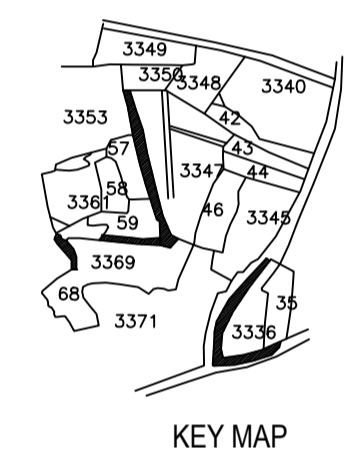
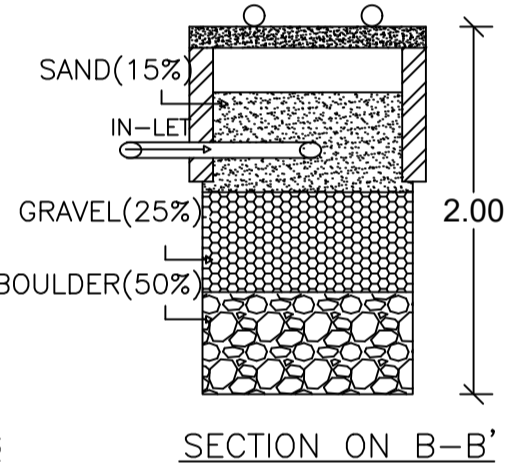
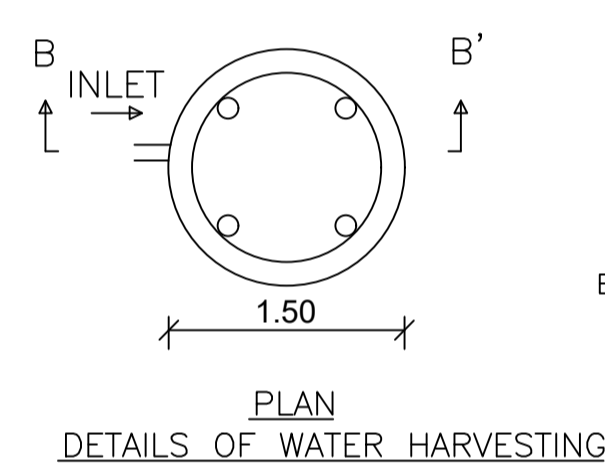
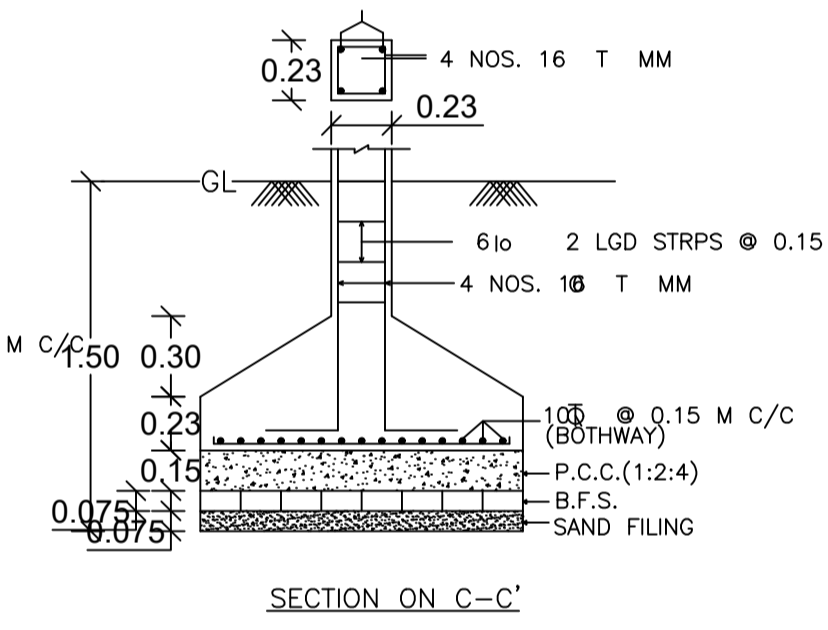
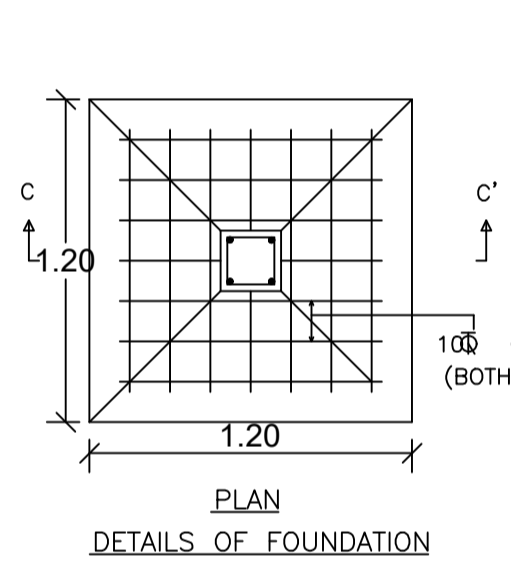
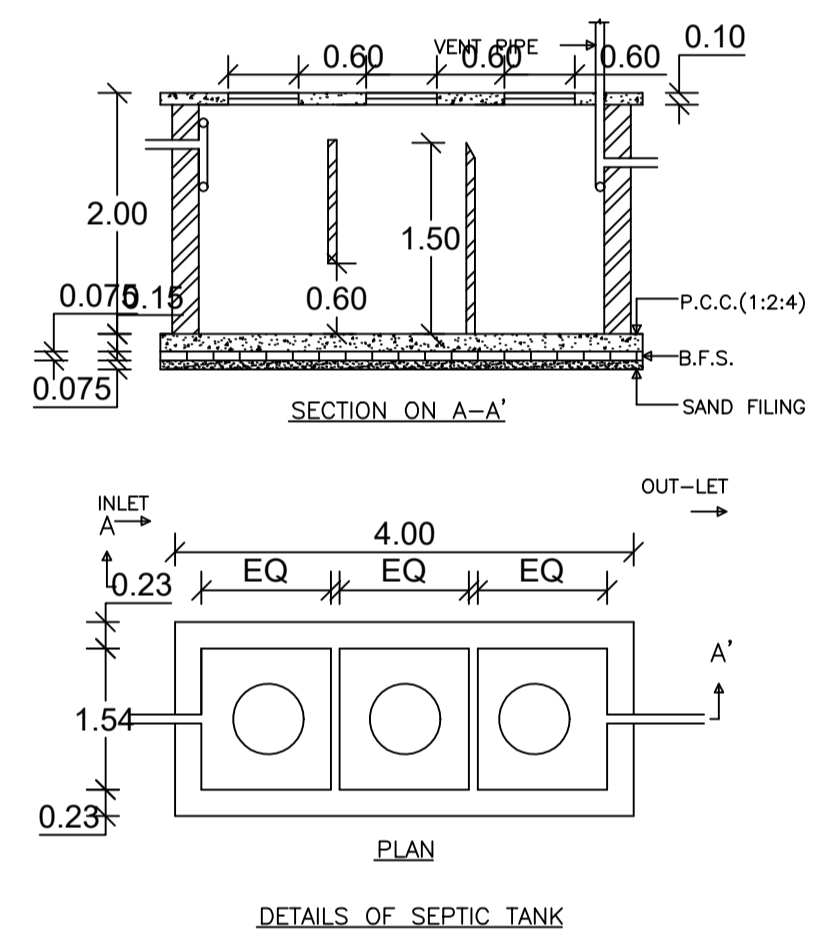
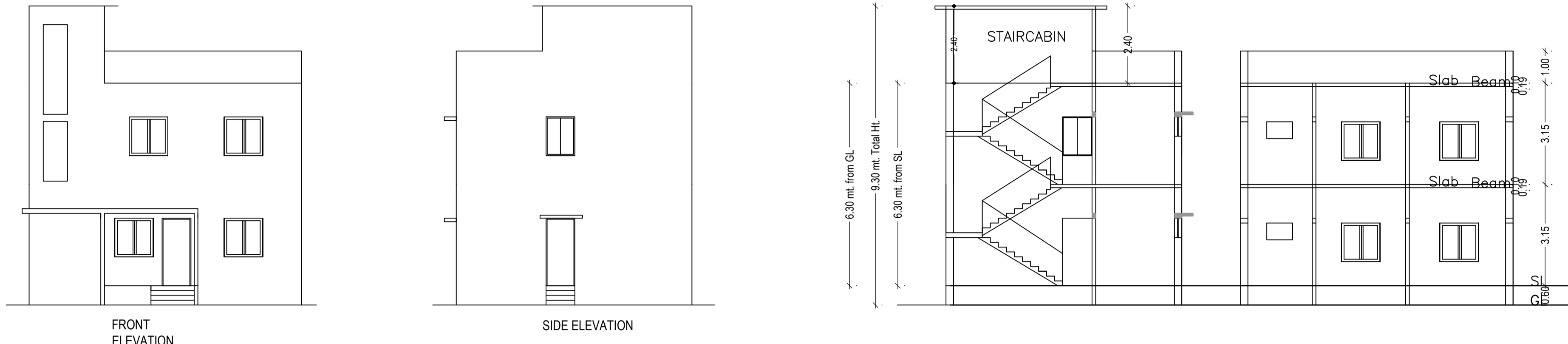

AREA STATEMENT CHAS MUNICIPAL CORPORATION		VERSION NO. : 1.0.64
PROJECT DETAIL:		VERSION DATE: 16/10/2020
Region: JHARKHAND URBAN LOCAL BODIES	Plot Use: Residential	
District: BOKARO	Plot SubUse: Bungalow/ Dwelling / Non Apartment	
Authority: CHAS MUNICIPAL CORPORATION	Plot/Nearby/ReligiousStructure: NA	
Inward No: CMC/BP/0283/W07/2022	Plot/SubPlot No: 3347	
Application Type: General Proposal	North: Plot No. - PLOT NO.-3342	
Project Type: Building Permission	South: Road Width - 4.57 MTR WIDE ROAD	
Nature of Development: New	East: CTS No. - SHANKAR PRASAD SAW	
Location of Development Area: Old Area	West: CTS No. - A/29 MARK LAND	
AREA DETAILS:		SQ.MT.
AREA OF PLOT (Minimum)	(A)	103.70
NET AREA OF PLOT(Gross Plot Area - Deduction from Gross Plot area)	(A-Deductions)	103.70
Deduction for Balance Plot Area(from Gross Plot Area)		
Common Plot		6.98
Total		6.98
BALANCE AREA OF PLOT/Net Plot Area - Recreational/Amenity space)	(A-Deductions)	96.72
PLOT AREA FOR COVERAGE(Net Plot Area)	(A-Deductions)	103.70
Plot Area for FAR (Net Plot Area + RoadWidening Area)	(A-Deductions)	103.70
COVERAGE CHECK		
Permissible Coverage area (70.00 %)		72.59
Proposed Coverage Area (56.64 %)		58.73
Total Prop. Coverage Area (56.64 %)		58.73
Balance coverage area (13.37 %)		13.86
FAR CHECK		
Perm. FAR Area (1.50)		155.55
Total Perm. FAR area		155.55
Residential FAR		117.47
Total Proposed FAR Area		117.47
Consumed FAR (Factor)		1.13
Balance FAR Area		38.08
BUILT UP AREA CHECK		
Total Proposed BuiltUp Area		117.46
ARCHITECT (Regd)		RAGHUNATH CHOUDHARY
ENGINEER (Regd)		
SUPERVISOR (Regd)		
OWNER (Regd)		ASHA DEVI
DEVELOPMENT AUTHORITY		LOCAL BODY

Building :A (ASHA)

Floor Name	Total Built Up Area (Sq.mt.)	Proposed FAR Area (Sq.mt.) Resi.	Total FAR Area (Sq.mt.)	Total Consumed Additional FAR Area (Sq.mt.)	Trmt (No.)
Ground Floor	58.73	58.73	58.73	58.73	01
First Floor	58.73	58.73	58.73	58.73	00
Terrace Floor	0.00	0.00	0.00	0.00	00
Total :	117.46	117.46	117.46	117.46	01
Total Number of Same Buildings	1				
Total :	117.46	117.46	117.46	117.46	01

SCHEDULE OF DOOR:

BUILDING NAME	NAME	LENGTH	HEIGHT	NOS
A (ASHA)	D2	0.75	2.10	02
A (ASHA)	D1	0.90	2.10	02
A (ASHA)	D	1.00	2.10	05

SCHEDULE OF WINDOW/VENTILATION:

BUILDING NAME	NAME	LENGTH	HEIGHT	NOS
A (ASHA)	V	0.60	1.20	04
A (ASHA)	W	1.20	1.20	04
A (ASHA)	W1	1.70	1.20	02

UnitBUA Table for Building :A (ASHA)

FLOOR	Name	UnitBUA Type	UnitBUA Area	Carpet Area	No. of Rooms	No. of Tenement
GROUND FLOOR PLAN	SPLIT A	FLAT	117.47	117.36	4	1
FIRST FLOOR PLAN	SPLIT A	FLAT	0.00	0.00	4	0
Total:	-	-	117.47	117.36	8	1

Buildingwise Floor FAR Details

Floor Name	Building Name		Total	
	Proposed Built Up Area (Sq.mt.)	Proposed FAR Area (Sq.mt.)	Total Proposed Built Up Area (Sq.mt.)	Total FAR Area (Sq.mt.)
Ground Floor	58.73	58.73	58.73	58.73
First Floor	58.73	58.73	58.73	58.73
Terrace Floor	0.00	0.00	0.00	0.00
Total :	117.46	117.46	117.46	117.46

Building USE/SUBUSE Details

Building Name	Building Use	Building SubUse	Building Structure
A (ASHA)	Residential	Bungalow/ Dwelling / Non Apartment	Non-Highrise

FAR & Tenement Details (Table 4c-1)

Building	No. of Same Bldg	Total Built Up Area (Sq.mt.)	Proposed FAR Area (Sq.mt.) Resi.	Total FAR Area (Sq.mt.)	Total Consumed Additional FAR Area (Sq.mt.)	Trmt (No.)
A (ASHA)	1	117.46	117.46	117.46	117.46	01
Grand Total :	1	117.46	117.46	117.46	117.46	01

COLOR INDEX

PLOT BOUNDARY	Black
ABUTTING ROAD	Red
PROPOSED CONSTRUCTION	Green
COMMON PLOT	Blue
ROAD WIDENING AREA	Yellow
EXISTING (To be retained)	Orange
EXISTING (To be demolished)	Purple

LTP NAME AND SIGNATURE	STRUCTURAL ENG'S NAME AND SIGNATURE	BUILDER NAME AND SIGNATURE	DIGITAL SIGNATURE
RAGHUNATH CHOUDHARY CMC/DFTMN/0004/2018			