

Proposal Basic Information	
Proposal File No.	CMC/BP/0291/W07/2022
Owner Name	SHRI RAM NARESH RAJAK AND SMT BINDU DEVI
Khata No	231,330
Plot No	2300,2311,2312
Village Name	Chas
Use	Residential
SubUse	Bungalow/ Dwelling / Non Apartment

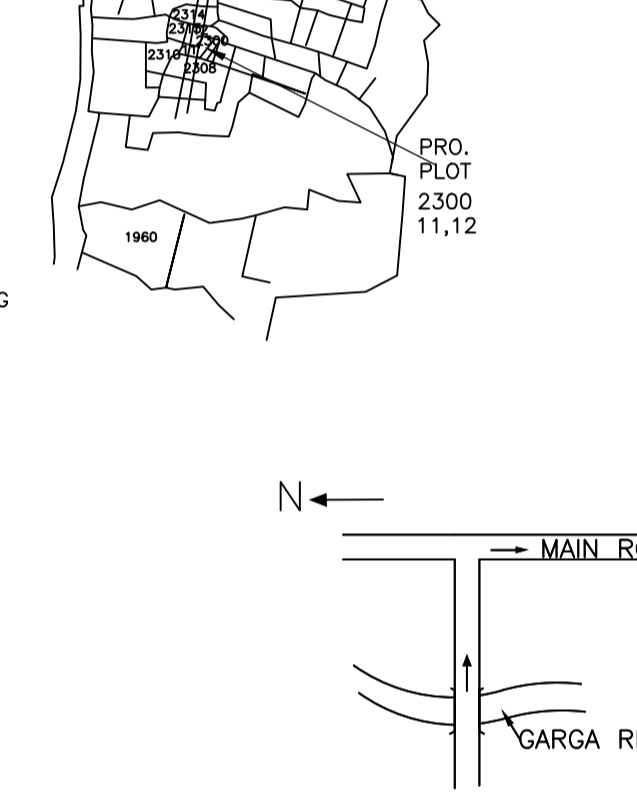

AREA STATEMENT CHAS MUNICIPAL CORPORATION		VERSION NO. : 1.0.64
PROJECT DETAIL:		VERSION DATE: 16/10/2020
Region: JHARKHAND URBAN LOCAL BODIES	Plot Use: Residential	
District: BOKARO	Plot SubUse: Bungalow/ Dwelling / Non Apartment	
Authority: CHAS MUNICIPAL CORPORATION	Plot/Nearby/Religious Structure: NA	
Inward No: CMC/BP/0291/W07/2022	Plot/SubPlot No: 2300,2311,2312	
Application Type: General Proposal	North: CTS No. - SHASHI NAGAR	
Project Type: Building Permission	South: CTS No. - SHASHI NAGAR	
Nature of Development: New	East: CTS No. - CHUNNI DEVI, SONU KUMARI AND SHASHI NAGAR	
Location of Development Area: Old Area	West: Road Width - 6.09 MTR ROAD	
AREA OF PLOT (Minimum)	(A)	SQ.MT. 222.60
Deduction for NetPlot Area		
Road Widening Area		28.62
Total		28.62
NET AREA OF PLOT (Gross Plot Area - Deduction from Gross Plot area)	(A-Deductions)	193.98
Deduction for Balance Plot Area (from Gross Plot Area)		
Road Widening Area		28.62
Common Plot		11.75
Total		40.37
BALANCE AREA OF PLOT (Net Plot Area - Recreational/Amenity space)	(A-Deductions)	182.23
PLOT AREA FOR COVERAGE (Net Plot Area)	(A-Deductions)	193.98
Plot Area for FAR (Net Plot Area + Road Widening Area)	(A-Deductions)	193.98
COVERAGE CHECK		
Permissible Coverage area ( 70.00 % )		135.79
Proposed Coverage Area ( 61.18 % )		118.68
Total Prop. Coverage Area ( 61.18 % )		118.68
Balance coverage area ( 8.82 % )		17.11
FAR CHECK		
Perm. FAR Area ( 1.80 )		349.16
Total Perm. FAR area		349.16
Residential FAR		207.06
Proposed FAR Area		207.06
Total Proposed FAR Area		207.06
Consumed FAR (Factor)		1.07
Balance FAR Area		142.10
BUILT UP AREA CHECK		
Total Proposed BuiltUp Area		225.66
ARCHITECT (Regd)		SUBHASH NARHARRAO NETRAGAONKAR
ENGINEER (Regd)		
SUPERVISOR (Regd)		
OWNER (Regd)		SHRI RAM NARESH RAJAK AND SMT BINDU DEVI
DEVELOPMENT AUTHORITY		LOCAL BODY

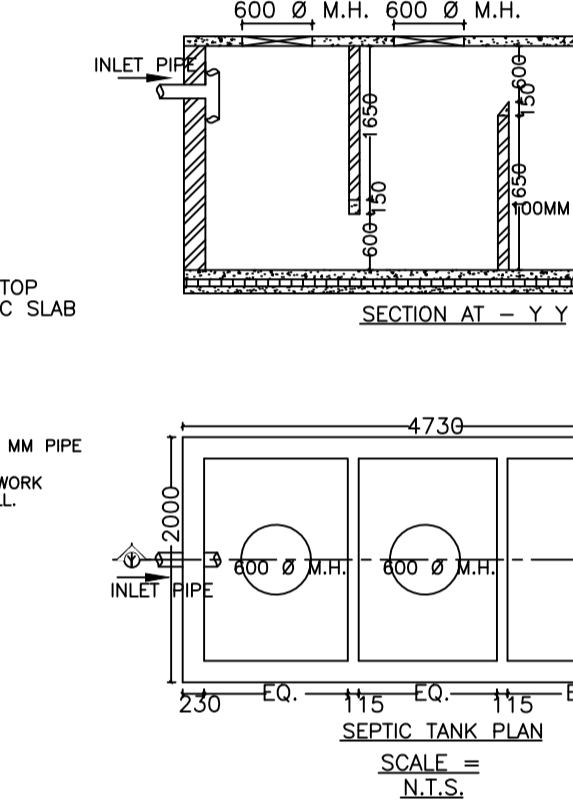
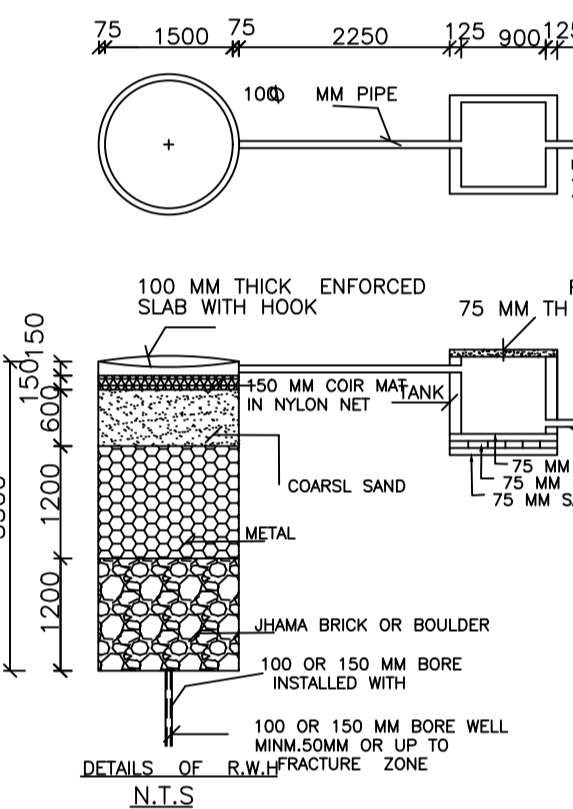
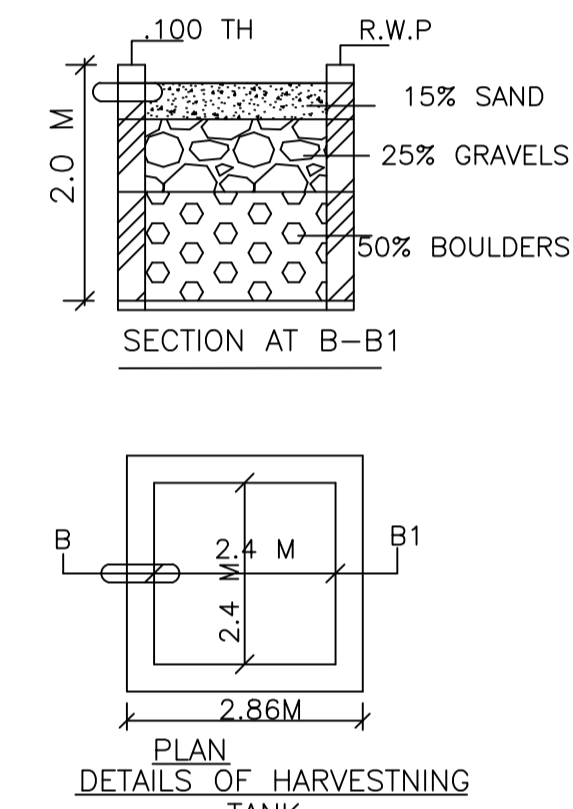
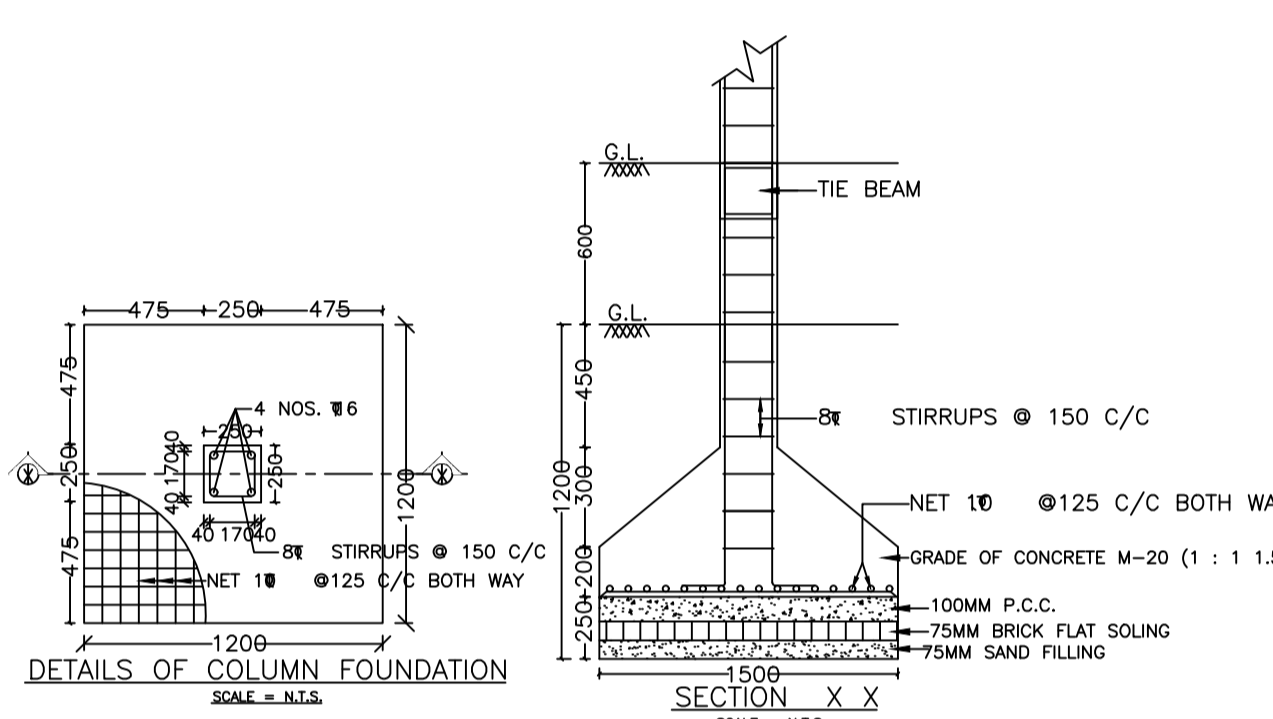
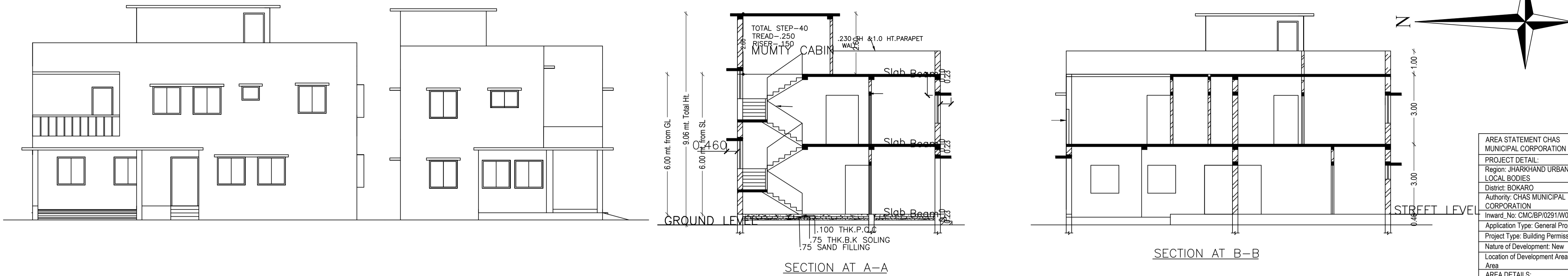
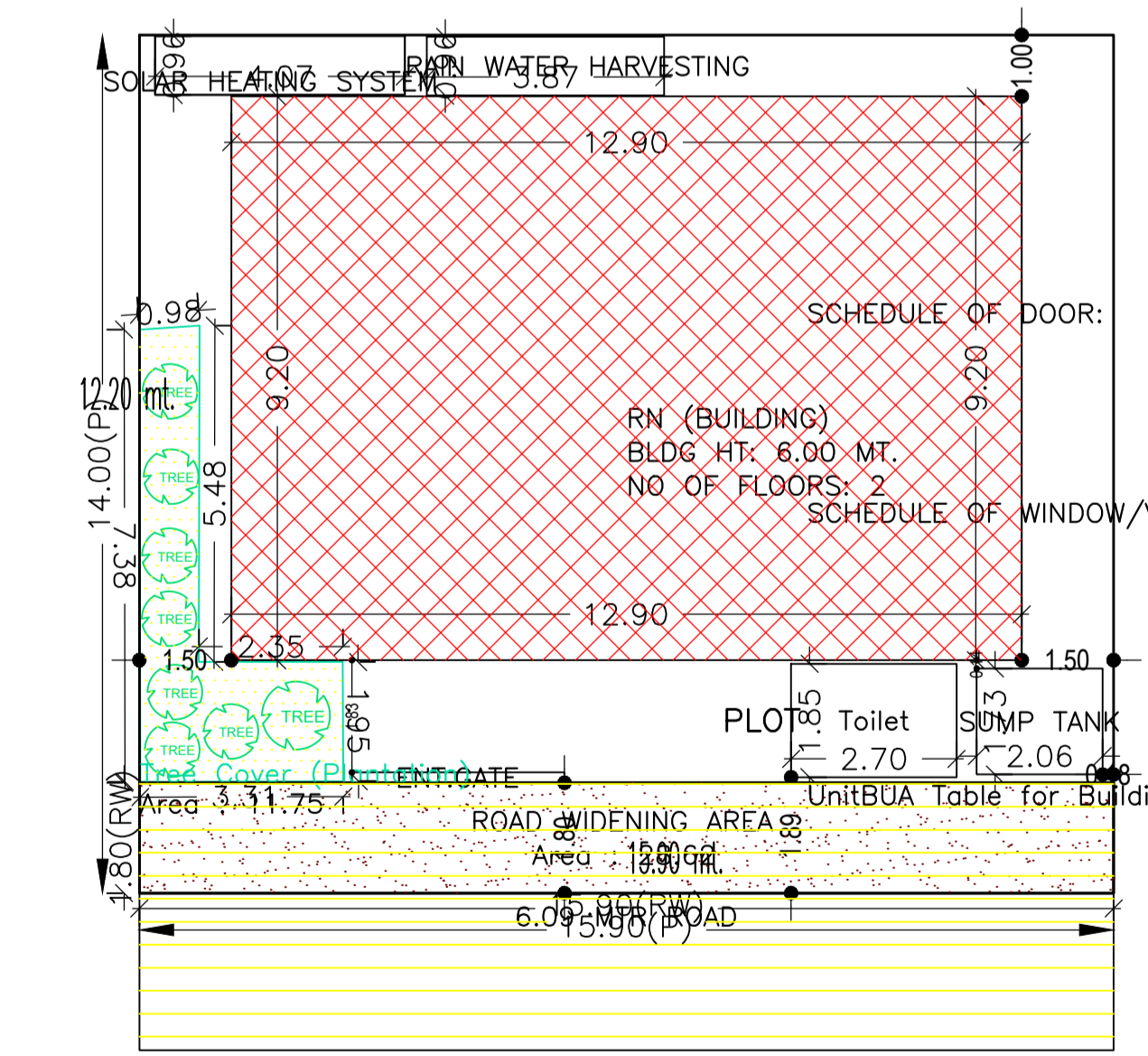
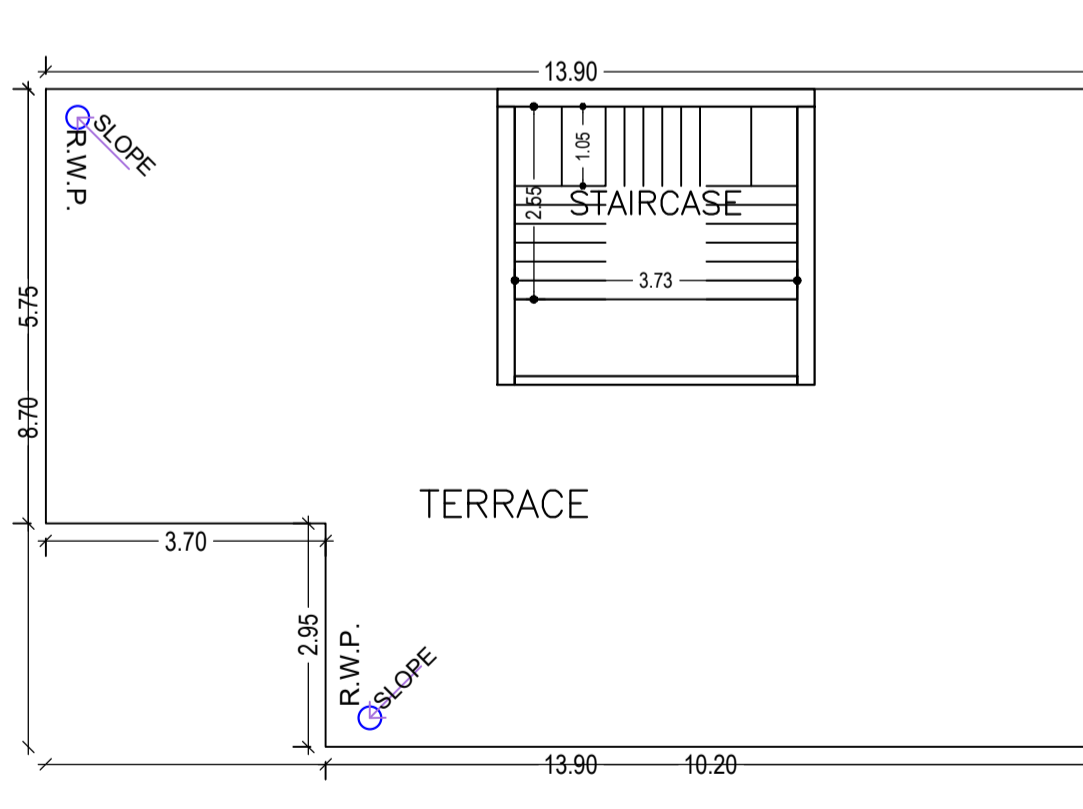
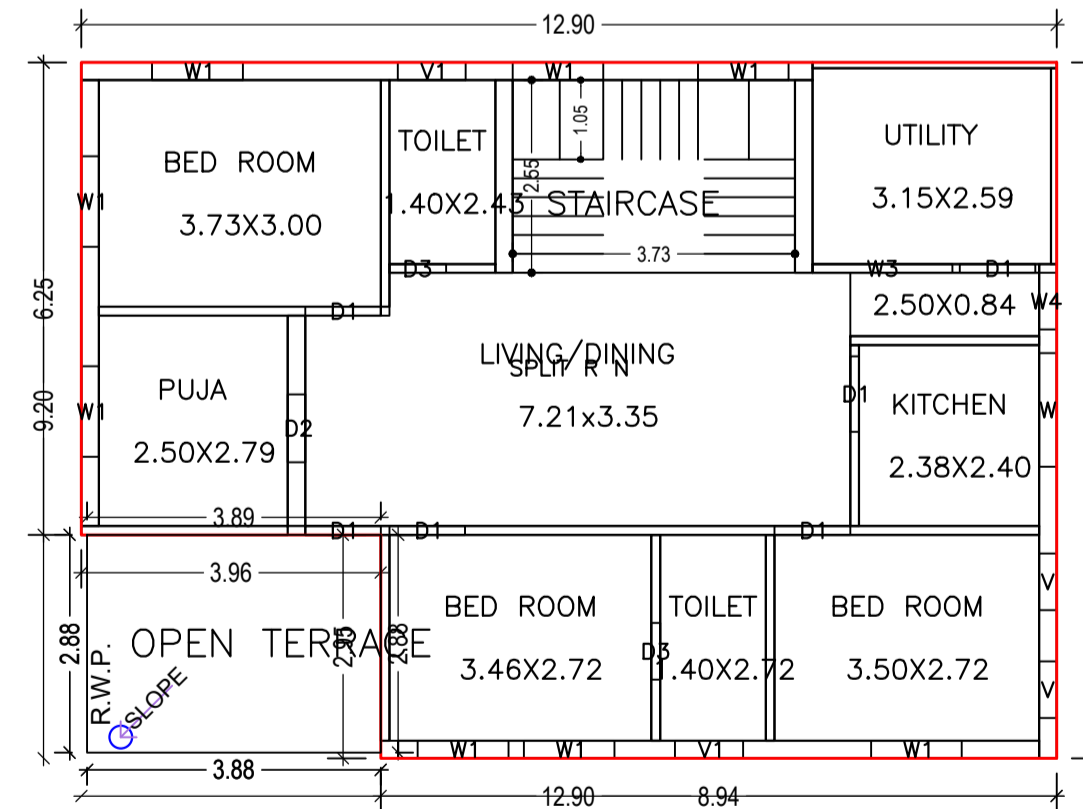
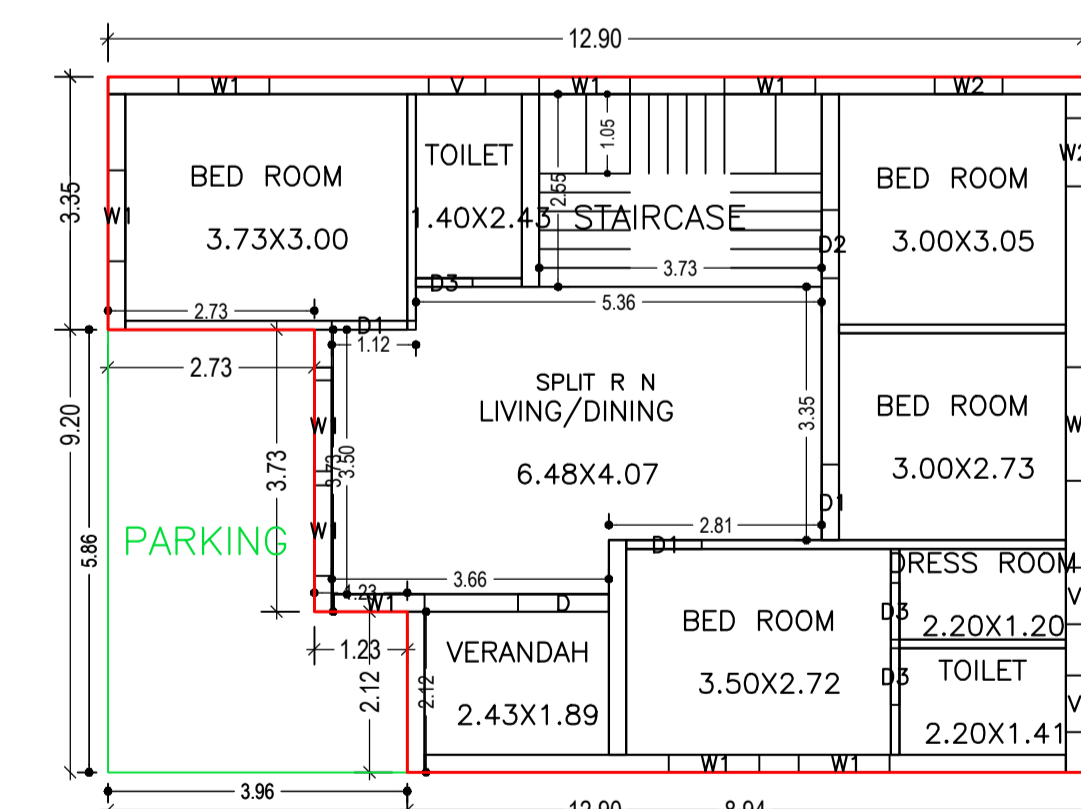

SCHEDULE OF DOOR:

BUILDING NAME	NAME	LENGTH	HEIGHT	NOS
RN (BUILDING)	D3	0.75	2.10	05
RN (BUILDING)	D2	0.90	2.10	02
RN (BUILDING)	D1	1.00	2.10	09
RN (BUILDING)	D	1.20	2.10	01

SCHEDULE OF WINDOW/VENTILATION:

BUILDING NAME	NAME	LENGTH	HEIGHT	NOS
RN (BUILDING)	V	0.75	0.60	05
RN (BUILDING)	W4	0.75	1.20	01
RN (BUILDING)	V1	0.90	0.60	02
RN (BUILDING)	W2	0.90	1.20	02
RN (BUILDING)	W1	1.20	1.20	17
RN (BUILDING)	W	1.50	1.20	02
RN (BUILDING)	W3	1.85	1.60	01

FAR & Tenement Details (Table 4c-1)

Building	No. of Same Bldg	Total Built Up Area (Sq.mt.)	Deductions (Area in Sq.mt.)	Proposed FAR Area (Sq.mt.)	Total FAR Area (Sq.mt.)	Total Consumed Additional FAR Area (Sq.mt.)	Tnmt (No.)
RN (BUILDING)	1	225.66	18.60	207.06	207.06	207.06	01
Grand Total :	1	225.66	18.60	207.06	207.06	207.06	01

Buildingwise Floor FAR Details

Floor Name	Building Name RN (BUILDING)		Total	
	Proposed Built Up Area (Sq.mt.)	Proposed FAR Area (Sq.mt.)	Total Proposed Built Up Area (Sq.mt.)	Total FAR Area (Sq.mt.)
Ground Floor	118.68	100.08	118.68	100.08
First Floor	106.98	106.98	106.98	106.98
Terrace Floor	0.00	0.00	0.00	0.00
Total :	225.66	207.06	225.66	207.06

UnitBUA Table for Building :RN (BUILDING)

FLOOR	Name	UnitBUA Type	UnitBUA Area	Carpet Area	No. of Rooms	No. of Tenement
GROUND FLOOR PLAN	SPLIT R N	FLAT	167.72	161.87	9	1
FIRST FLOOR PLAN	SPLIT R N	FLAT	0.00	0.00	9	0
Total:	-	-	167.72	161.87	18	1

COLOR INDEX

PLOT BOUNDARY	Black
ABUTTING ROAD	Green
PROPOSED CONSTRUCTION	Red
COMMON PLOT	Yellow
ROAD WIDENING AREA	Blue
EXISTING (To be retained)	Orange
EXISTING (To be demolished)	Light Blue

LTP NAME AND SIGNATURE

STRUCTURAL ENG'S NAME AND SIGNATURE	BUILDER NAME AND SIGNATURE	DIGITAL SIGNATURE
SUBHASH NARHARRAO NETRAGAONKAR CMC/ARC/0014/2018		