

Proposal Basic Information

Proposal File No.	CMC/BP/0235/W17/2022
Owner Name	JOYSHNA CHANDRA MANJHI
Khata No	66
Plot No	3769,3770
Village Name	Chas
Use	Residential
SubUse	Bungalow/ Dwelling / Non Apartment

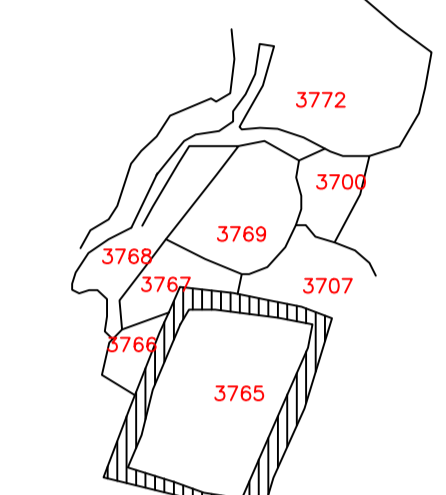

AREA STATEMENT CHAS MUNICIPAL CORPORATION	VERSION NO.: 1.0.64 VERSION DATE: 16/10/2020	SQ.MT.
PROJECT DETAIL:		
Region: JHARKHAND URBAN LOCAL BODIES	Plot Use: Residential	
District: BOKARO	Plot SubUse: Bungalow/ Dwelling / Non Apartment	
Authority: CHAS MUNICIPAL CORPORATION	PlotNearby/ReligiousStructure: NA	
Inward No: CMC/BP/0235/W17/2022	Plot/SubPlot No: 3769,3770	
Application Type: General Proposal	North: CTS No. - ASHOK MAL	
Project Type: Building Permission	South: CTS No. - SAPAN CHANDRA THAKUR	
Nature of Development: New	East: Road Width - ROAD	
Location of Development Area: Old Area	West: Plot No. - PLOT NO. - 3770 (PART) & NALA	
AREA OF PLOT (Minimum)	(A)	80.95
NET AREA OF PLOT (Gross Plot Area - Deduction from Gross Plot area)	(A-Deductions)	80.95
Deduction for Balance Plot Area (from Gross Plot Area)		
Common Plot		5.87
Total		5.87
BALANCE AREA OF PLOT (Net Plot Area - Recreational/Amenity space)	(A-Deductions)	75.08
PLOT AREA FOR COVERAGE (Net Plot Area)	(A-Deductions)	80.95
Plot Area for FAR (Net Plot Area + Road Widening Area)	(A-Deductions)	80.95
COVERAGE CHECK		
Permissible Coverage area ( 70.00 % )		56.66
Proposed Coverage Area ( 62.47 % )		50.57
Total Prop. Coverage Area ( 62.47 % )		50.57
Balance coverage area ( 7.52 % )		6.09
FAR CHECK		
Perm. FAR Area ( 1.50 )		121.42
Total Perm. FAR area		121.42
Residential FAR		104.30
Proposed FAR Area		104.30
Total Proposed FAR Area		104.30
Consumed FAR (Factor)		1.29
Balance FAR Area		17.12
BUILT UP AREA CHECK		
Total Proposed BuiltUp Area		104.30
ARCHITECT (Regd)	AMRIT KUMAR MAHATO	
ENGINEER (Regd)		
SUPERVISOR (Regd)		
OWNER (Regd)	JOYSHNA CHANDRA MANJHI	
DEVELOPMENT AUTHORITY		LOCAL BODY

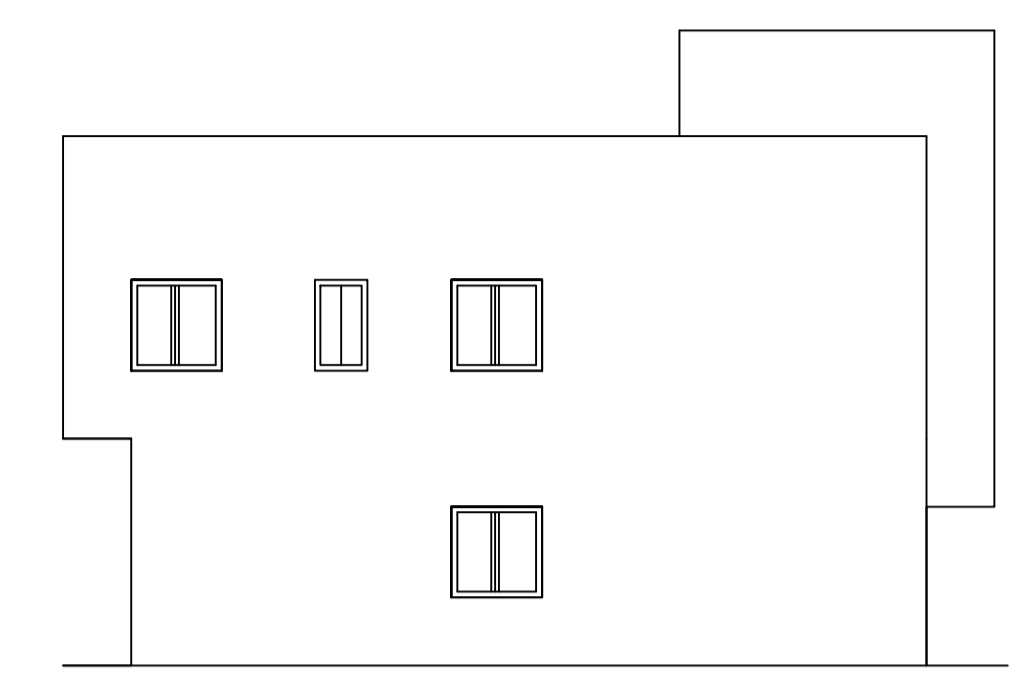
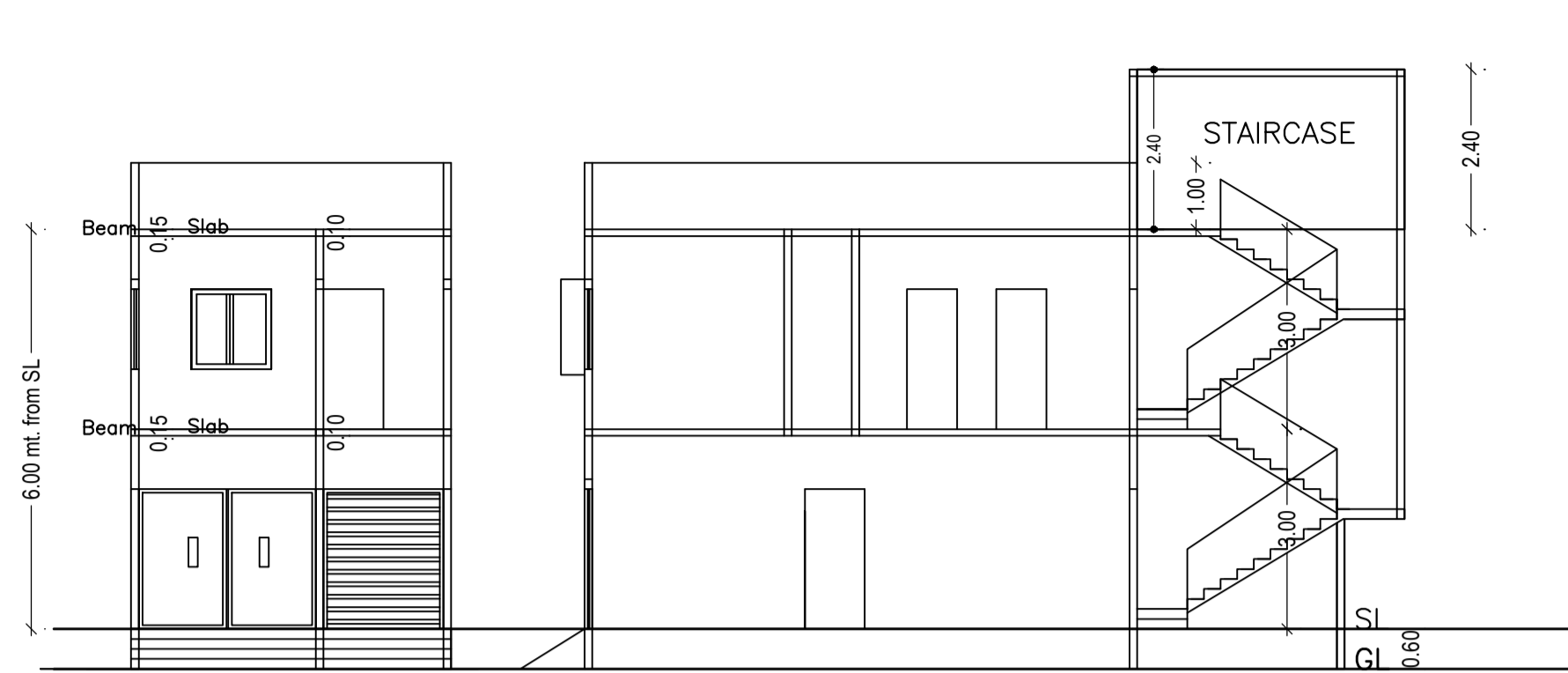
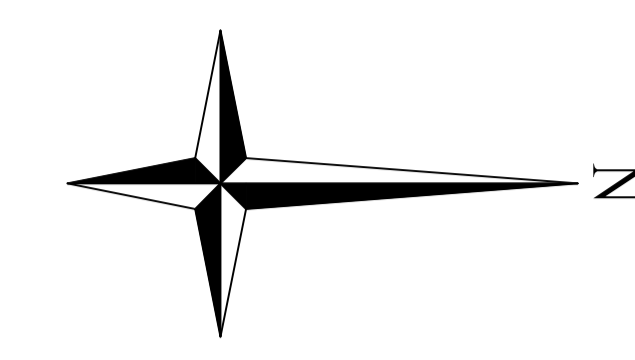
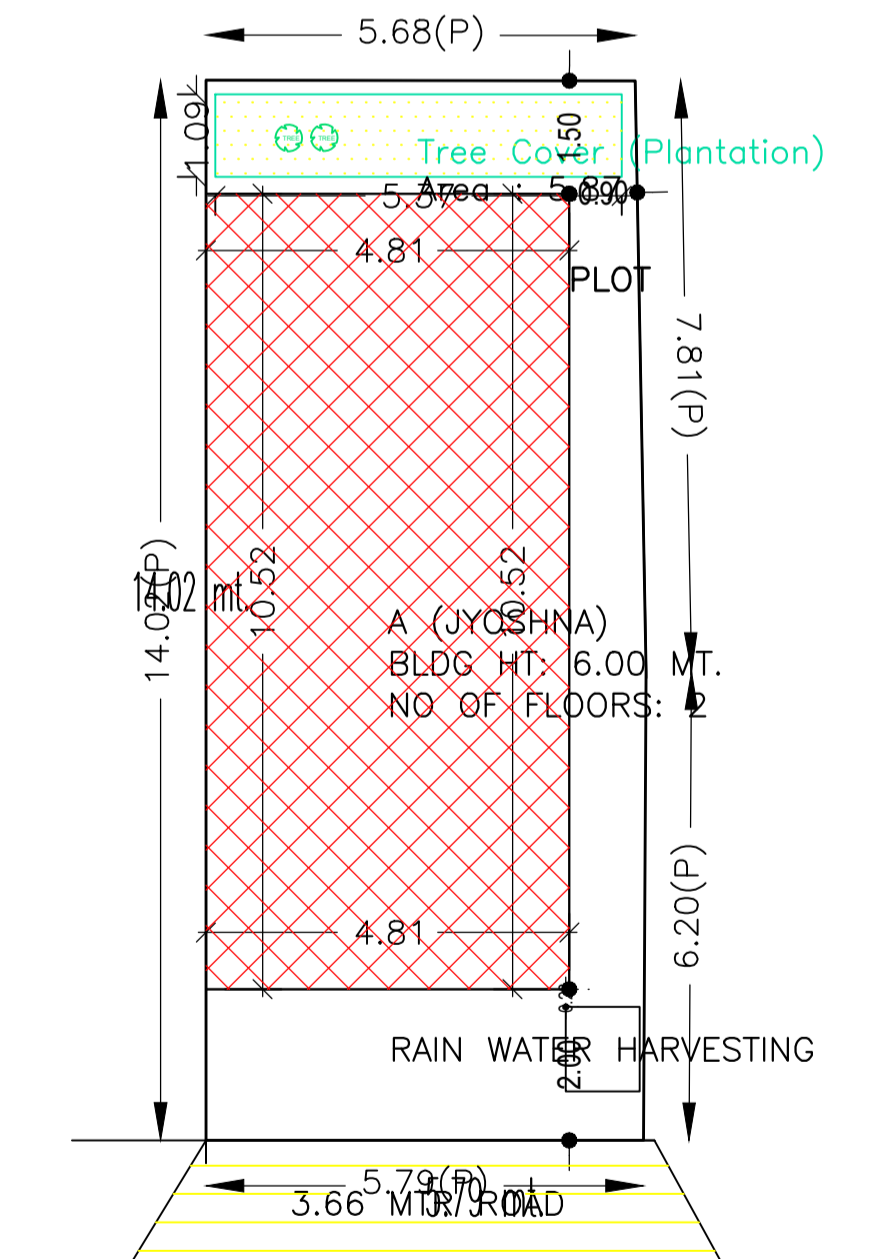
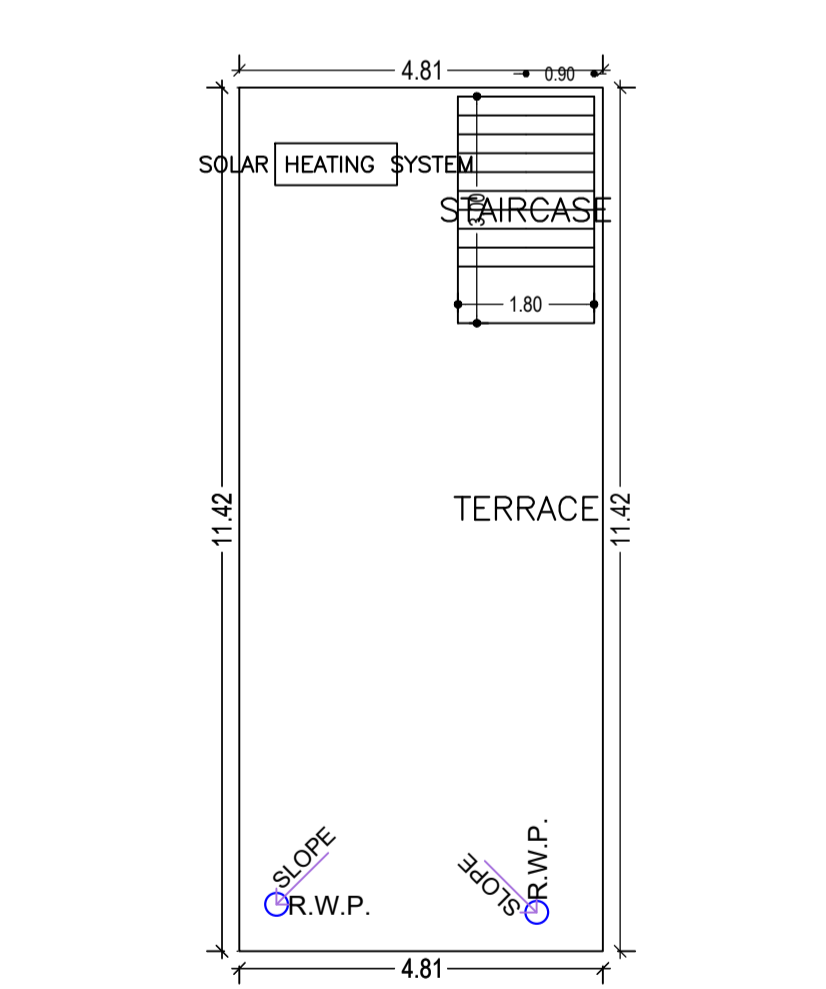
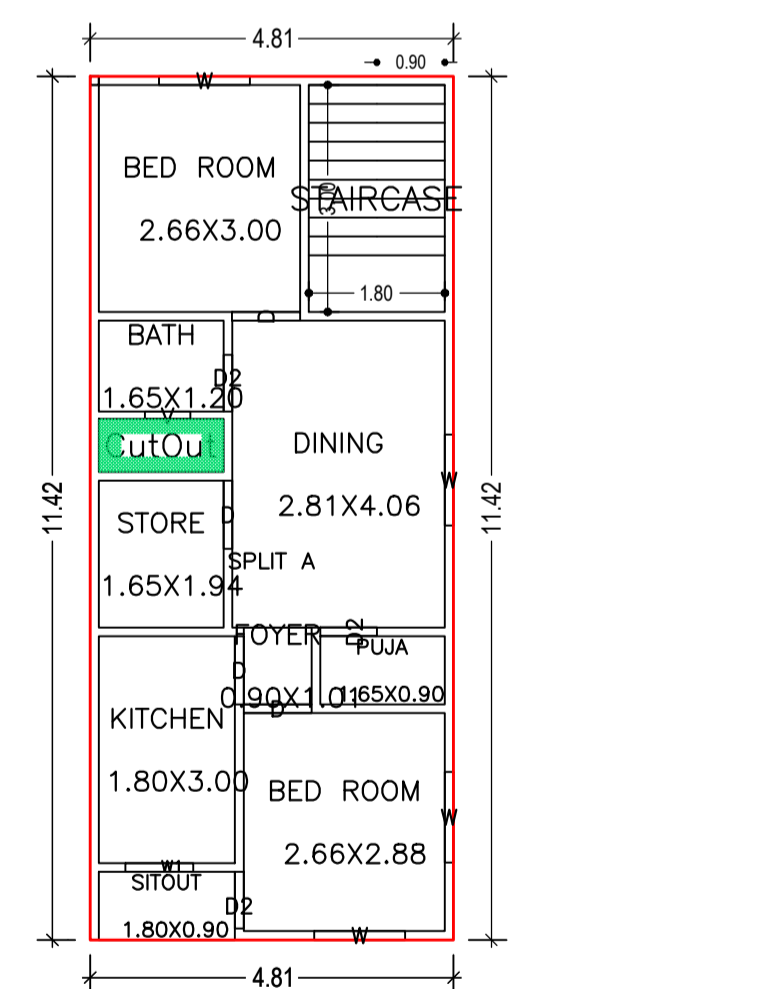
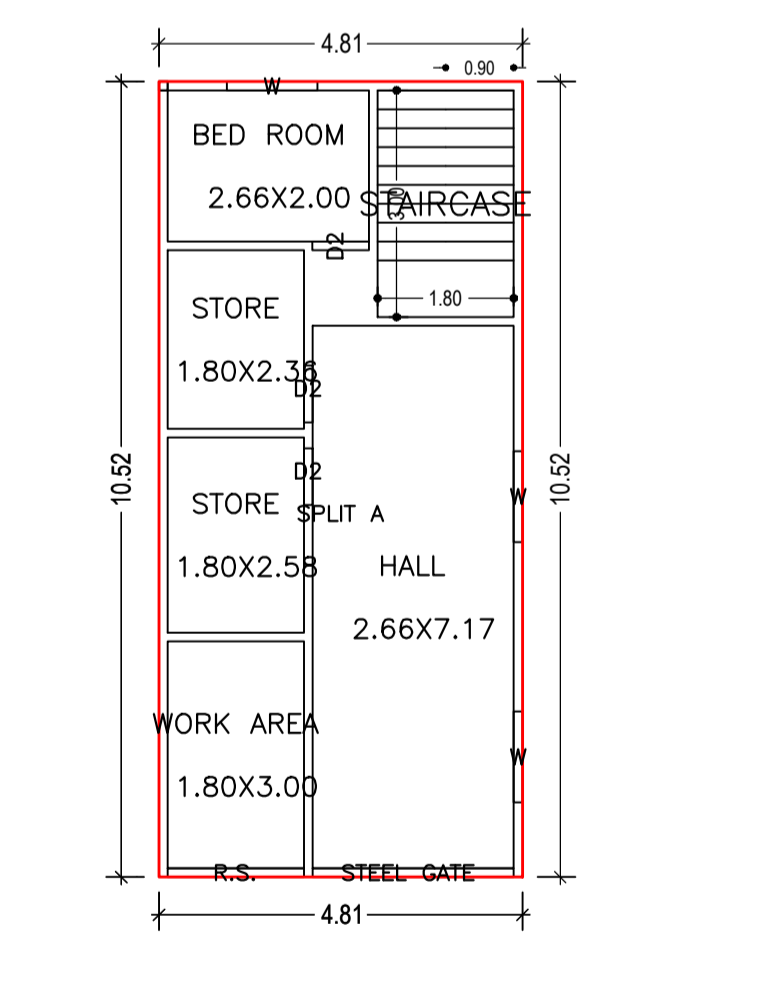
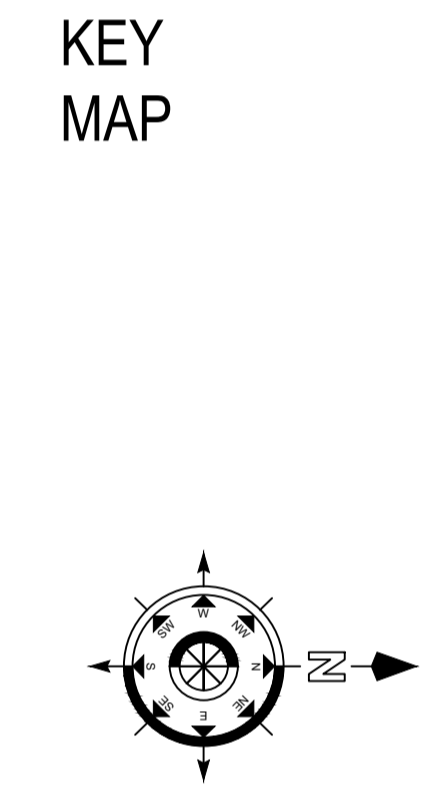
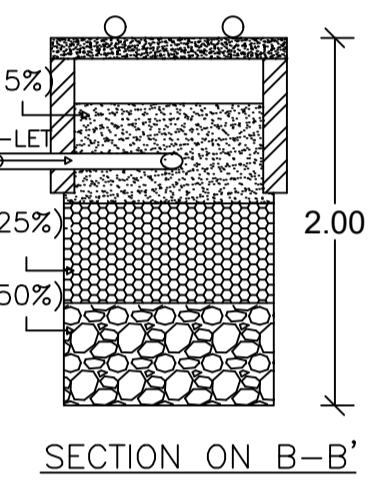
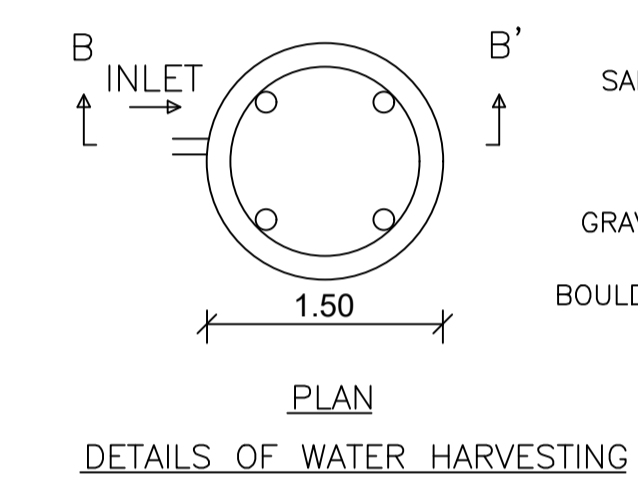
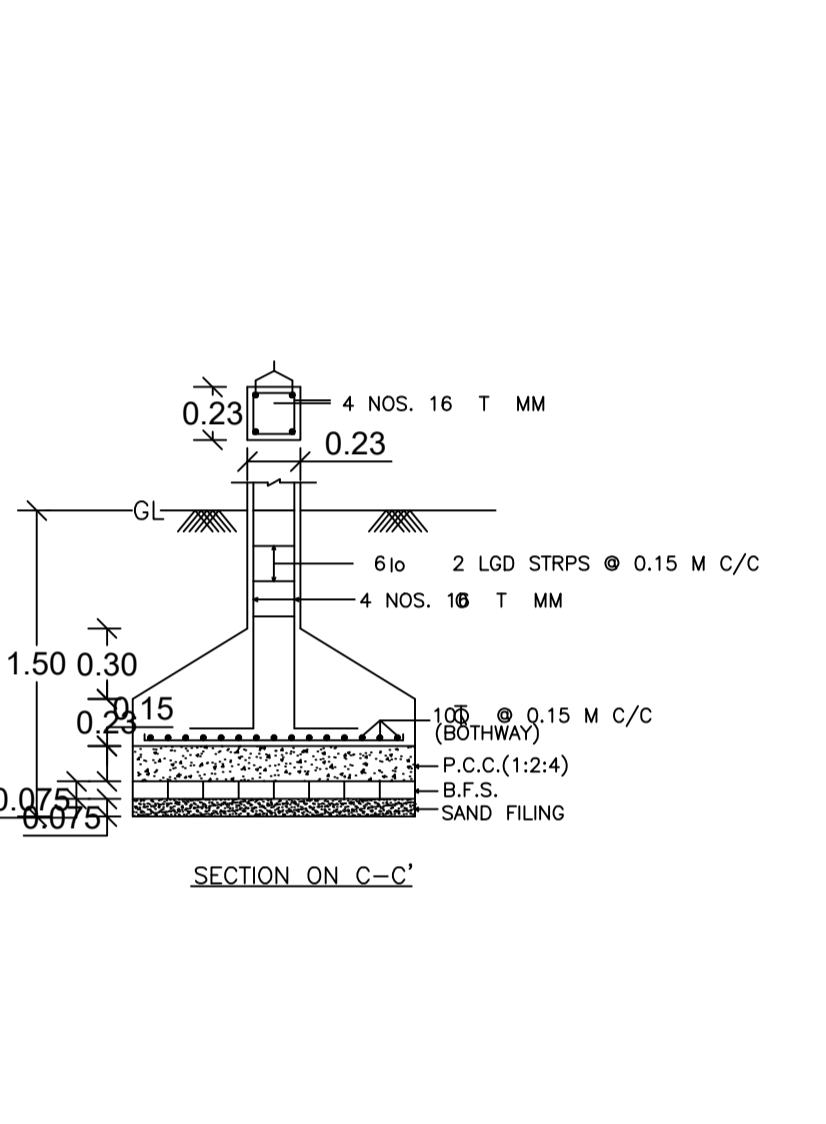
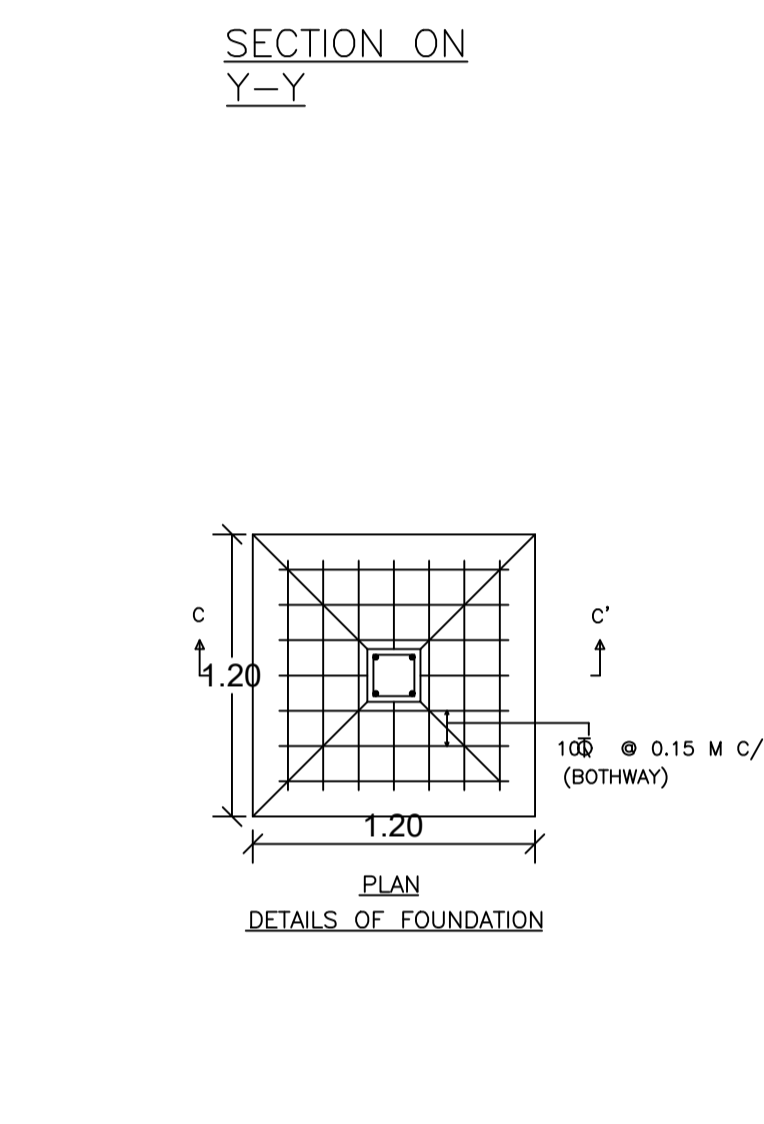
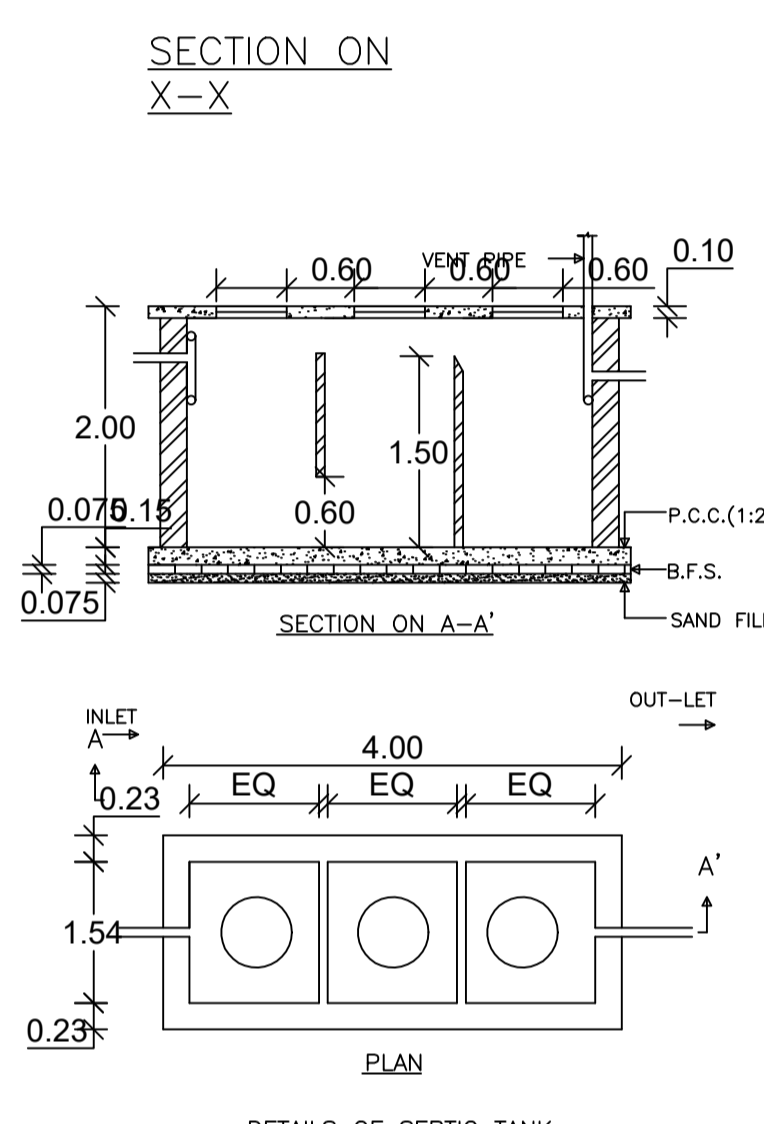

SCHEDULE OF DOOR:				
BUILDING NAME	NAME	LENGTH	HEIGHT	NOS
A (JYOSHNA)	D2	0.75	2.10	06
A (JYOSHNA)	D	0.90	2.10	04
A (JYOSHNA)	R.S.	1.80	2.10	01
A (JYOSHNA)	STEEL GATE	2.65	2.10	01

SCHEDULE OF WINDOW/VENTILATION:				
BUILDING NAME	NAME	LENGTH	HEIGHT	NOS
A (JYOSHNA)	V	0.60	1.20	01
A (JYOSHNA)	W1	0.90	1.20	01
A (JYOSHNA)	W	1.20	1.20	07

Building :A (JYOSHNA)							
Floor Name	Gross Builtup Area	Deductions From Gross BUA/Area in Sq.m.)	Total Built Up Area (Sq.m.)	Proposed FAR Area (Sq.m.)	Total FAR Area (Sq.m.)	Total Consumed Additional FAR Area (Sq.m.)	Trmt (No.)
Ground Floor	50.57	0.00	50.57	50.57	50.57	50.57	01
First Floor	54.89	1.16	53.73	53.73	53.73	53.73	00
Terrace Floor	0.00	0.00	0.00	0.00	0.00	0.00	00
Total :	105.46	1.16	104.30	104.30	104.30	104.30	01
Total Number of Same Buildings :	1						
Total :	105.46	1.16	104.30	104.30	104.30	104.30	01

FAR & Tenement Details (Table 4c-1)								
Building	No. of Same Bldg	Gross Built Up Area (Sq.m.)	Deductions From Gross BUA/Area in Sq.m.)	Total Built Up Area (Sq.m.)	Proposed FAR Area (Sq.m.)	Total FAR Area (Sq.m.)	Total Consumed Additional FAR Area (Sq.m.)	Trmt (No.)
A (JYOSHNA)	1	105.46	1.16	104.30	104.30	104.30	104.30	01
Grand Total :	1	105.46	1.16	104.30	104.30	104.30	104.30	01

Floor Name	Building Name A (JYOSHNA)		Total	
	Proposed Built Up Area (Sq.m.)	Proposed FAR Area (Sq.m.)	Total Proposed Built Up Area (Sq.m.)	Total FAR Area (Sq.m.)
Ground Floor	50.57	50.57	50.57	50.57
First Floor	53.73	53.73	53.73	53.73
Terrace Floor	0.00	0.00	0.00	0.00
Total :	104.30	104.30	104.30	104.30

UnitBUA Table for Building :A (JYOSHNA)							
FLOOR	Name	UnitBUA Type	UnitBUA Area	Carpet Area	No. of Rooms	No. of Tenement	
FIRST FLOOR PLAN	SPLIT A	FLAT	0.00	0.00	9	0	
GROUND FLOOR PLAN	SPLIT A	FLAT	104.30	104.27	5	1	
Total:	-	-	104.30	104.27	14	1	

Building USE/SUBUSE Details			
Building Name	Building Use	Building SubUse	Building Structure
A (JYOSHNA)	Residential	Bungalow/ Dwelling / Non Apartment	Non-Highrise

COLOR INDEX		SITE PLAN	
PLOT BOUNDARY	ABUTTING ROAD	PROPOSED CONSTRUCTION	COMMON PLOT
ROAD WIDENING AREA	EXISTING (To be retained)	EXISTING (To be demolished)	

LTP NAME AND SIGNATURE	STRUCTURAL ENG'S NAME AND SIGNATURE	BUILDER NAME AND SIGNATURE	DIGITAL SIGNATURE
AMRIT KUMAR MAHATO CMC/DFTM/0004/2019			