

Proposal Basic Information

Proposal File No.	CMC/BP/0241/W07/2022
Owner Name	KUSUM MISHRA
Khata No	375
Plot No	3347
Village Name	Chas
Use	Residential
SubUse	Bungalow/ Dwelling / Non Apartment

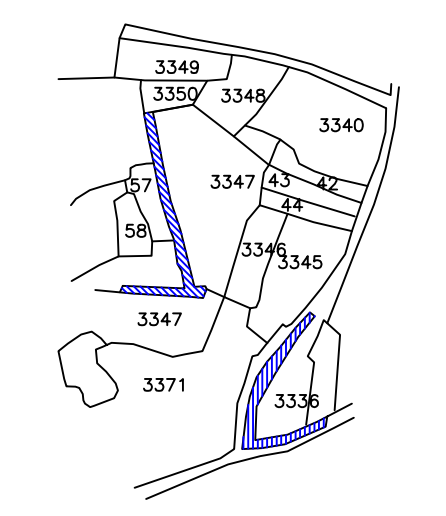

KEY MAP

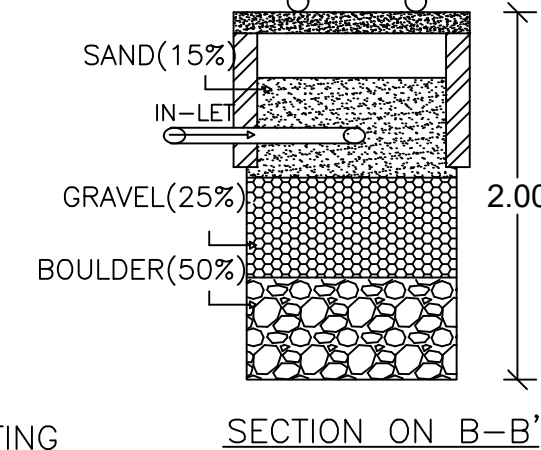
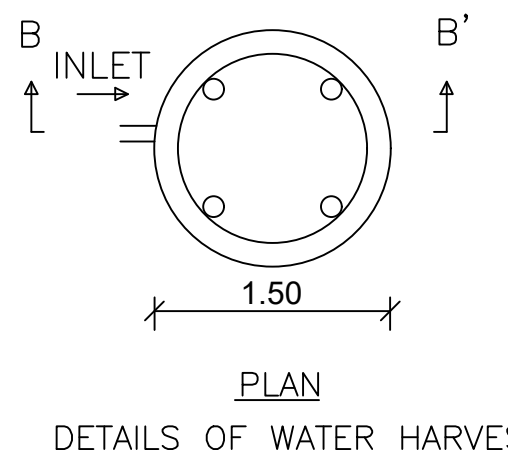
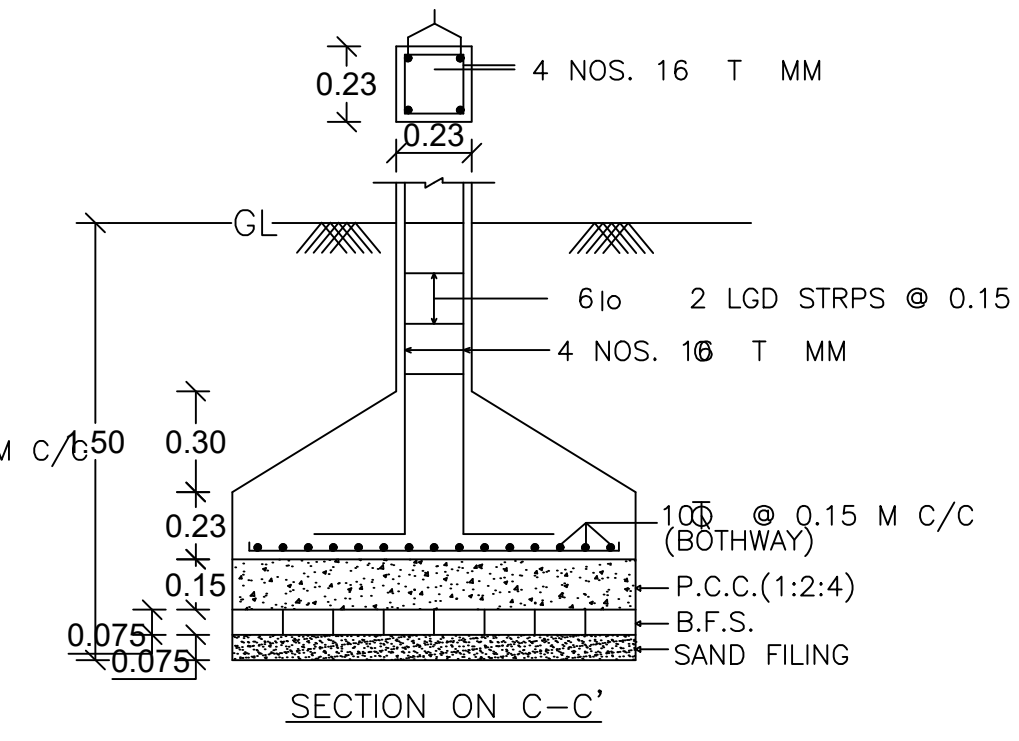
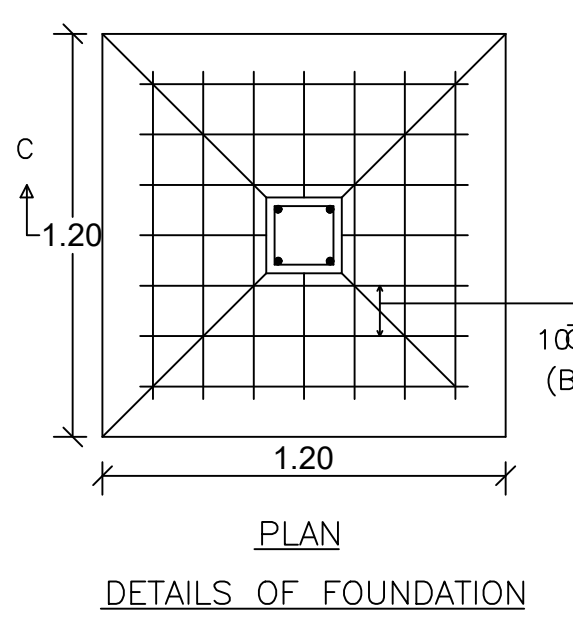
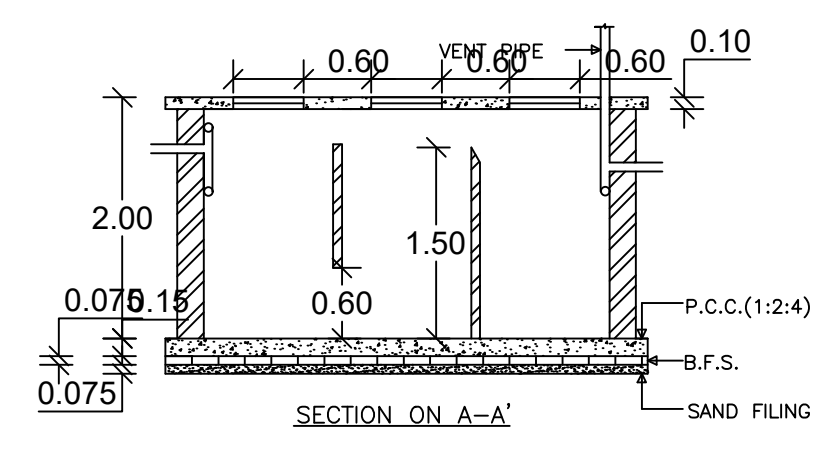
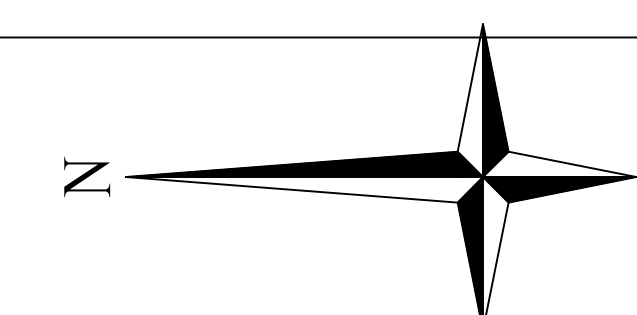
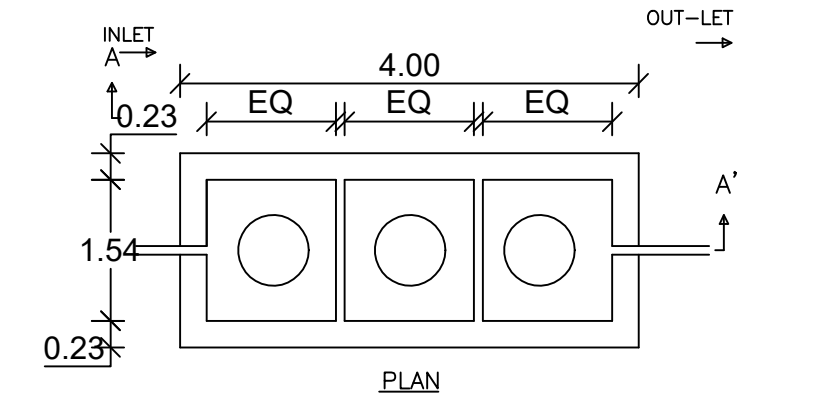

AREA STATEMENT CHAS MUNICIPAL CORPORATION	VERSION NO.: 1.0.64	
	VERSION DATE: 16/10/2020	
PROJECT DETAIL:		
Region: JHARKHAND URBAN LOCAL BODIES	Plot Use: Residential	
District: BOKARO	Plot SubUse: Bungalow/ Dwelling / Non Apartment	
Authority: CHAS MUNICIPAL CORPORATION	PlotNearby/ReligiousStructure: NA	
Inward No: CMC/BP/0241/W07/2022	Plot/SubPlot No: 3347	
Application Type: General Proposal	North: CTS No. - VENDOR NU LAND	
Project Type: Building Permission	South: Road Width - 4.57 MTR WIDE ROAD	
Nature of Development: New	East: CTS No. - VENDOR NU LAND	
Location of Development Area: Old Area	West: Road Width - 4.57 MTR WIDE ROAD	
AREA DETAILS:		
AREA OF PLOT (Minimum)	(A)	SQ.MT. 252.12
NET AREA OF PLOT(Gross Plot Area - Deduction from Gross Plot area)	(A-Deductions)	252.12
Deduction for Balance Plot Area(from Gross Plot Area)		
Total		22.42
Common Plot		22.42
BALANCE AREA OF PLOT(Net Plot Area - Recreational/Amenity space)		
(A-Deductions)		229.70
PLOT AREA FOR COVERAGE(Net Plot Area)		
(A-Deductions)		252.12
Plot Area for FAR (Net Plot Area + RoadWidening Area)		
(A-Deductions)		252.12
COVERAGE CHECK		
Permissible Coverage area (60.00 %)		151.27
Proposed Coverage Area (59.89 %)		151.00
Total Prop. Coverage Area (59.89 %)		151.00
Balance coverage area (0.11 %)		0.27
FAR CHECK		
Perm. FAR Area (1.50)		378.18
Total Perm. FAR area		378.18
Residential FAR		330.71
Proposed FAR Area		330.71
Total Proposed FAR Area		330.71
Consumed FAR (Factor)		1.31
Balance FAR Area		47.47
BUILT UP AREA CHECK		
Total Proposed BuiltUp Area		330.71
ARCHITECT (Regd)	AMRIT KUMAR MAHATO	
ENGINEER (Regd)		
SUPERVISOR (Regd)		
OWNER (Regd)	KUSUM MISHRA	
DEVELOPMENT AUTHORITY		LOCAL BODY

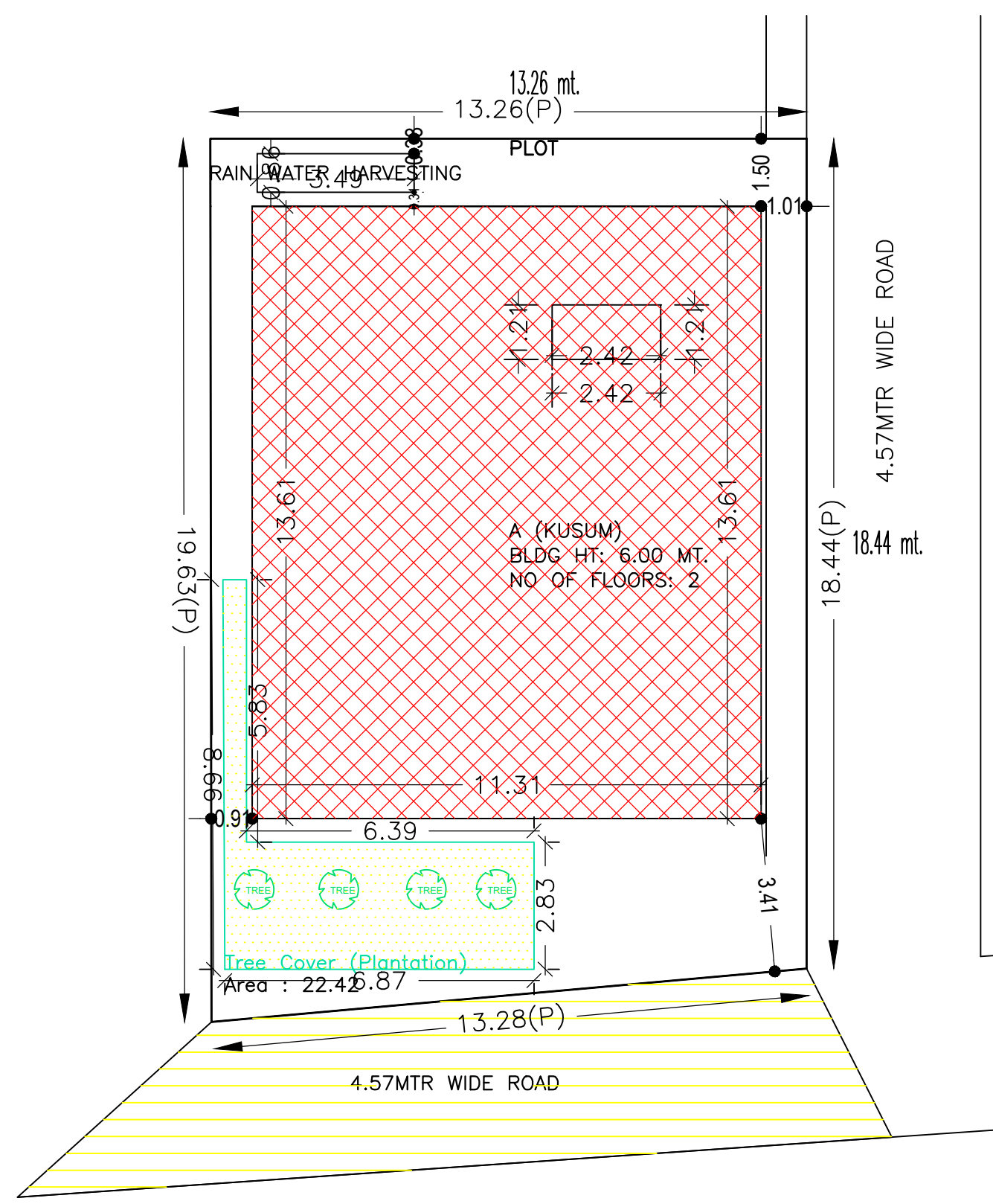
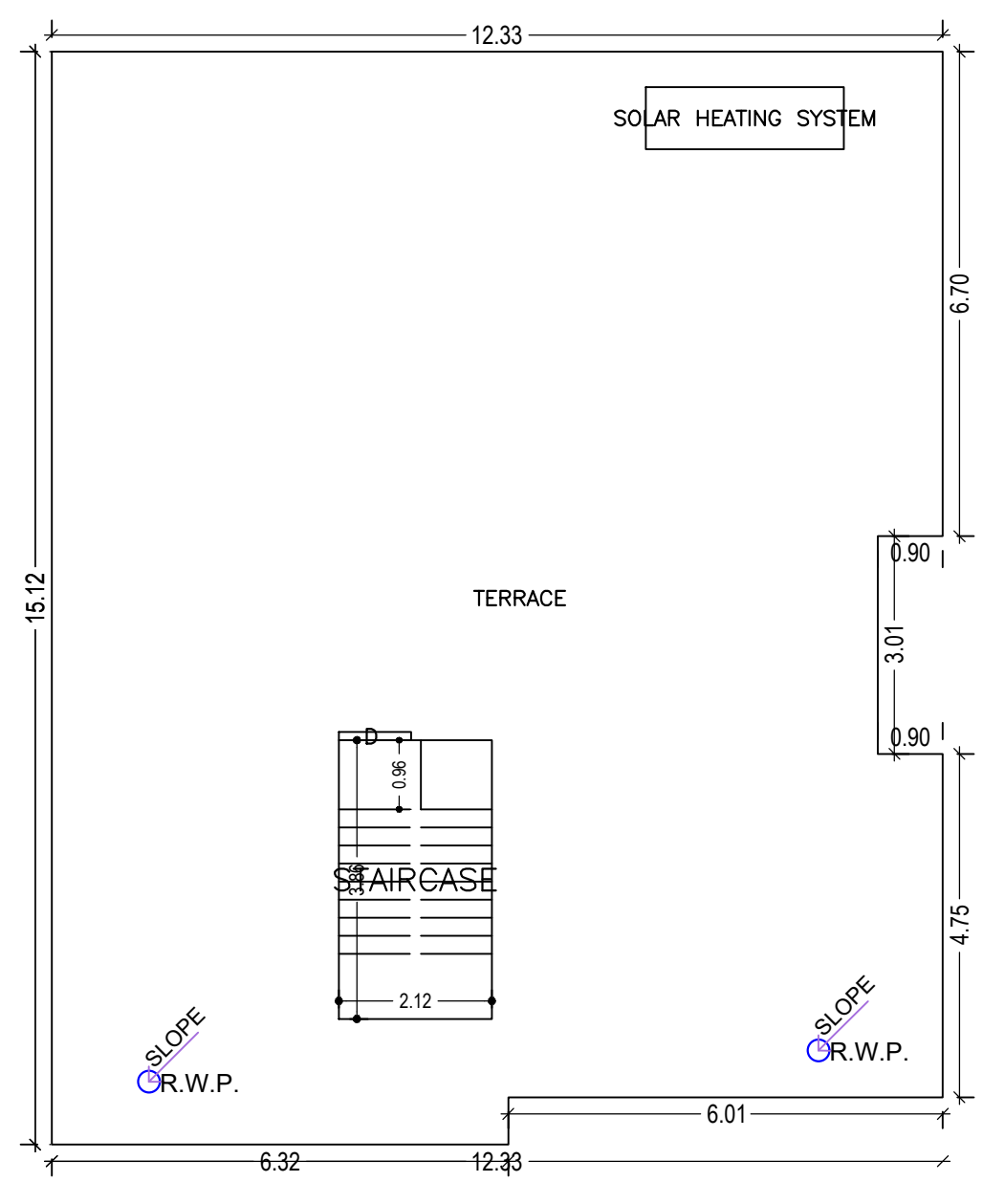
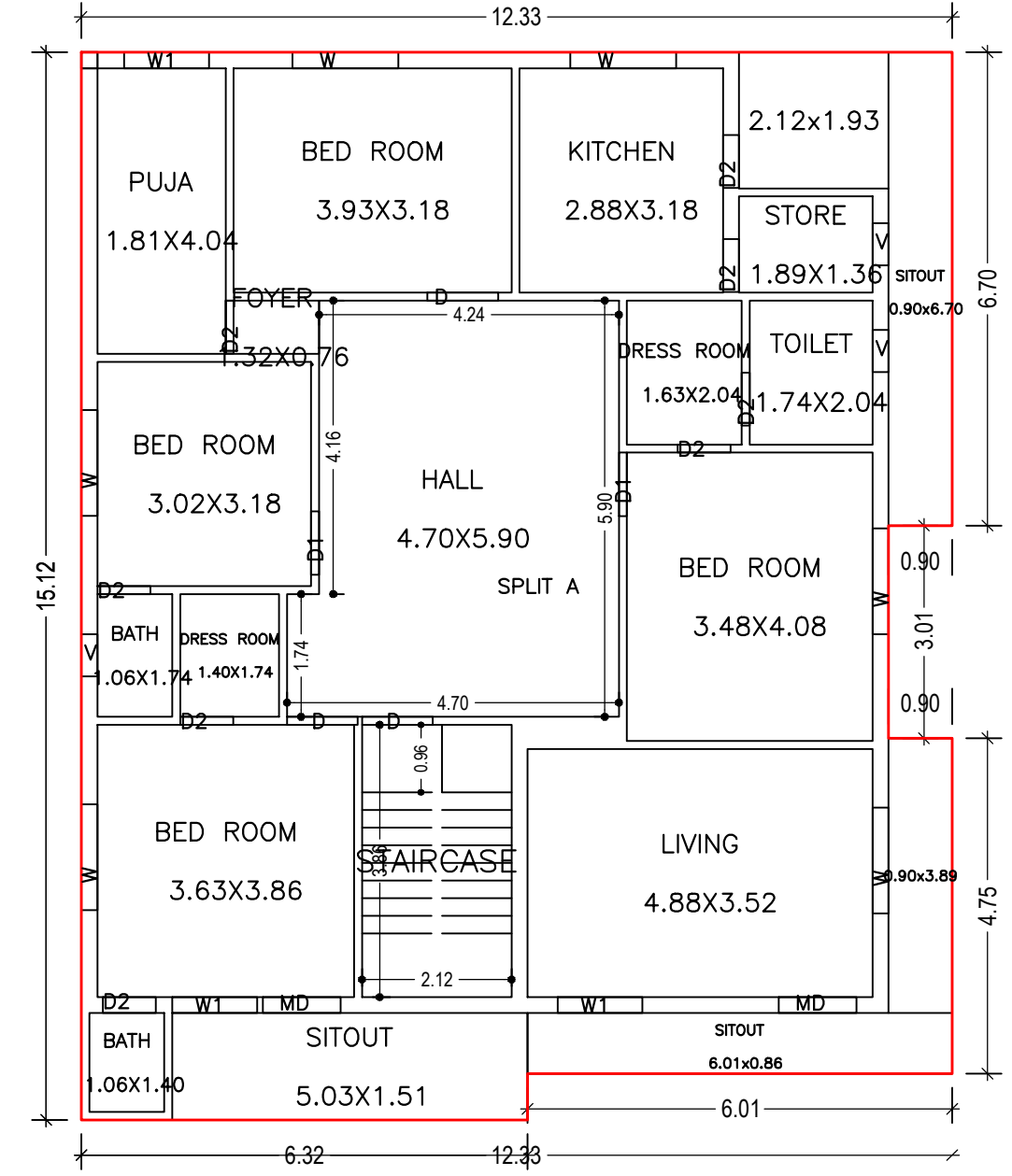
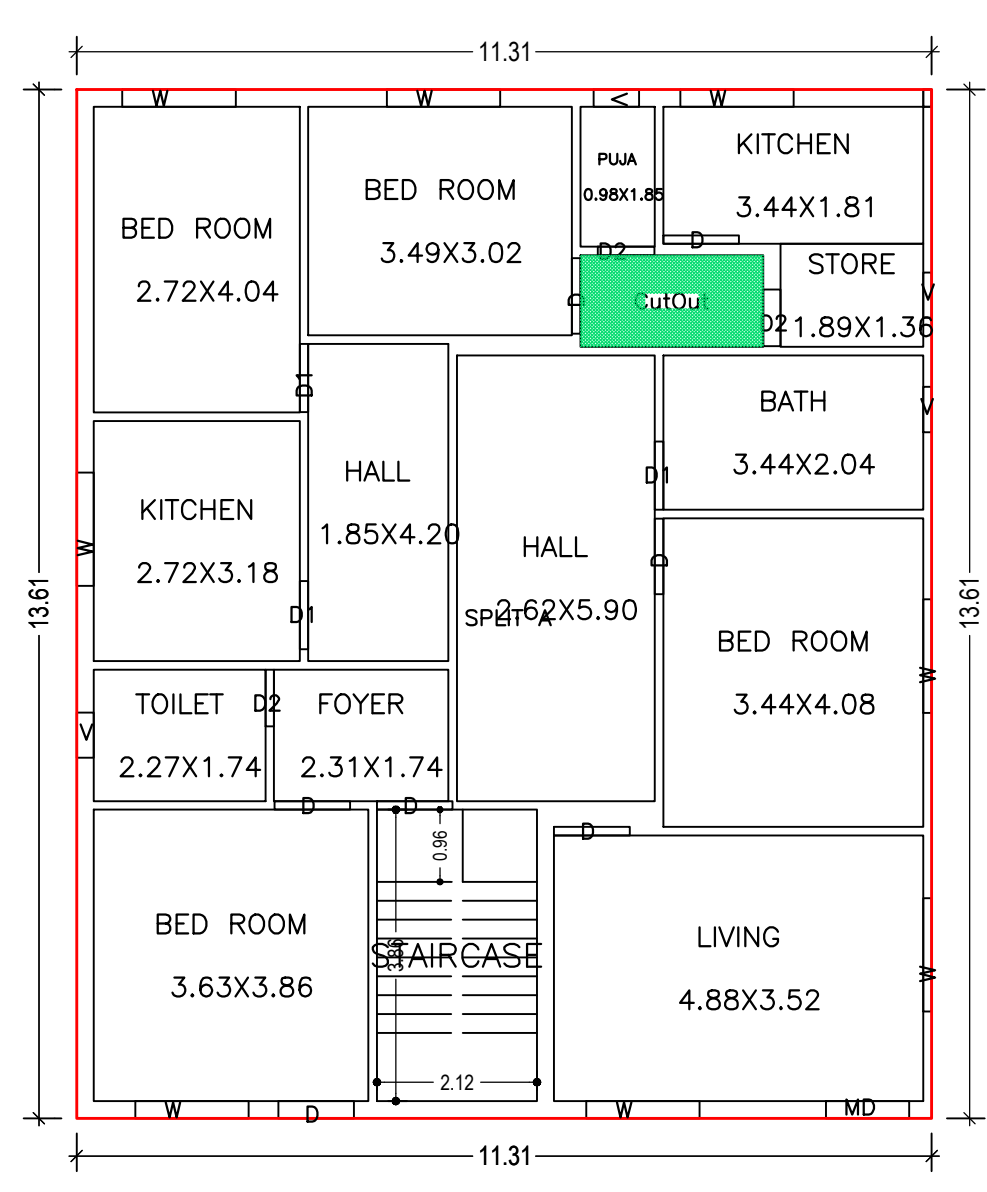
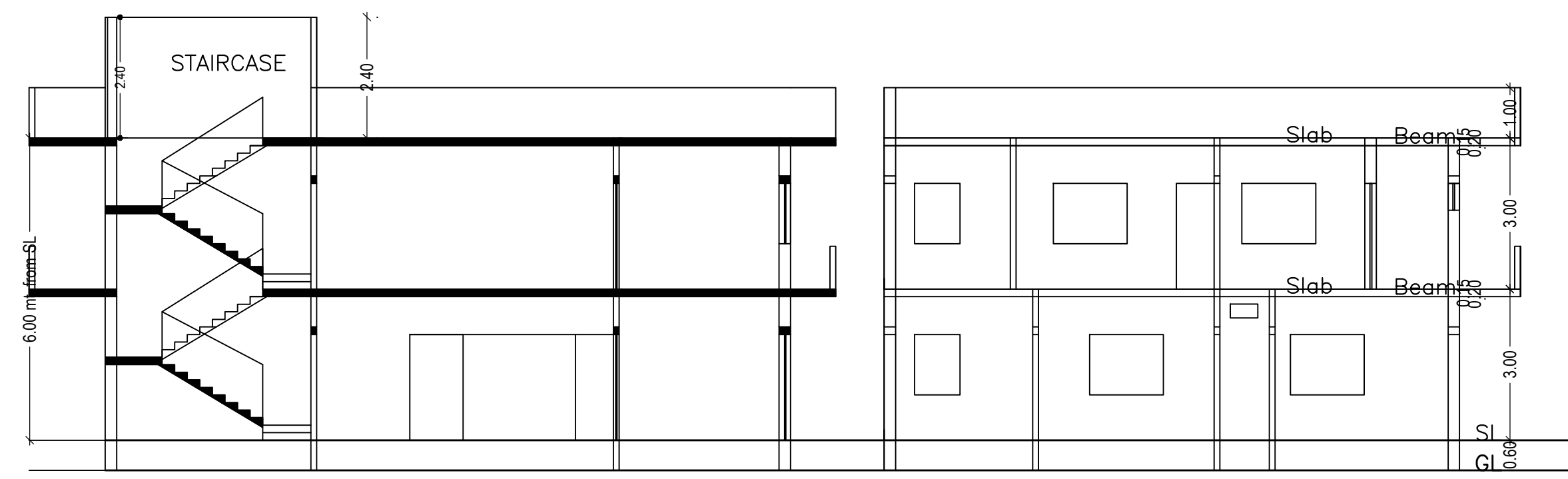
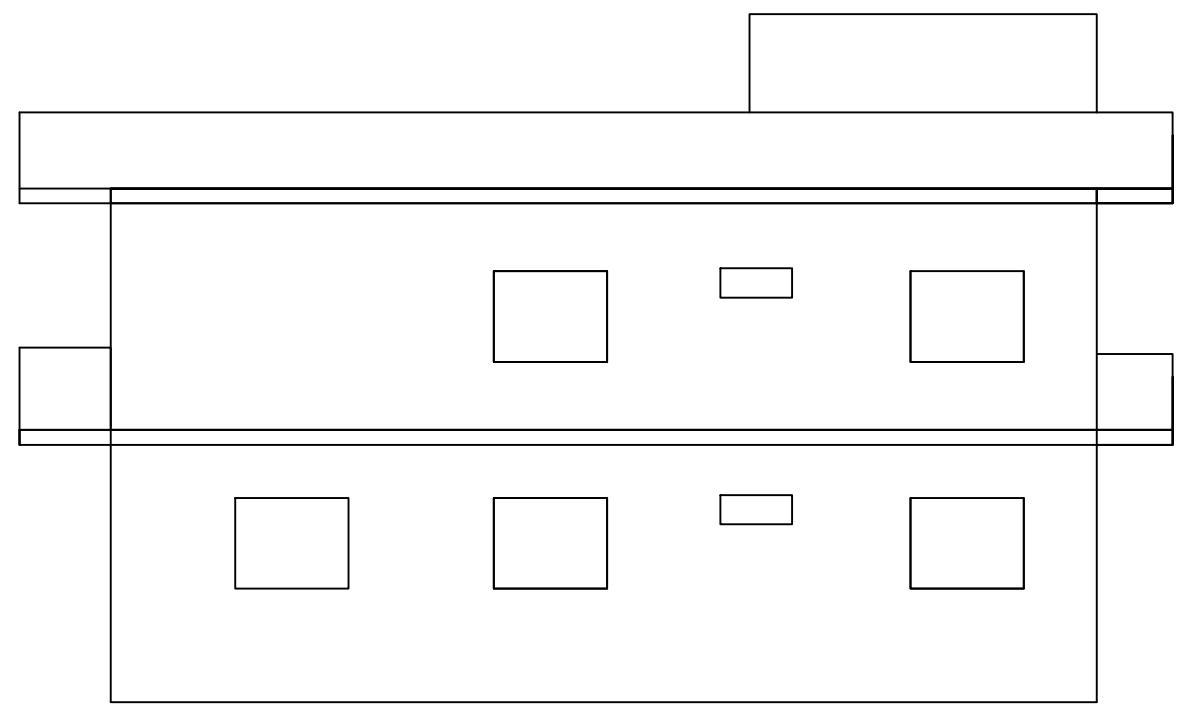
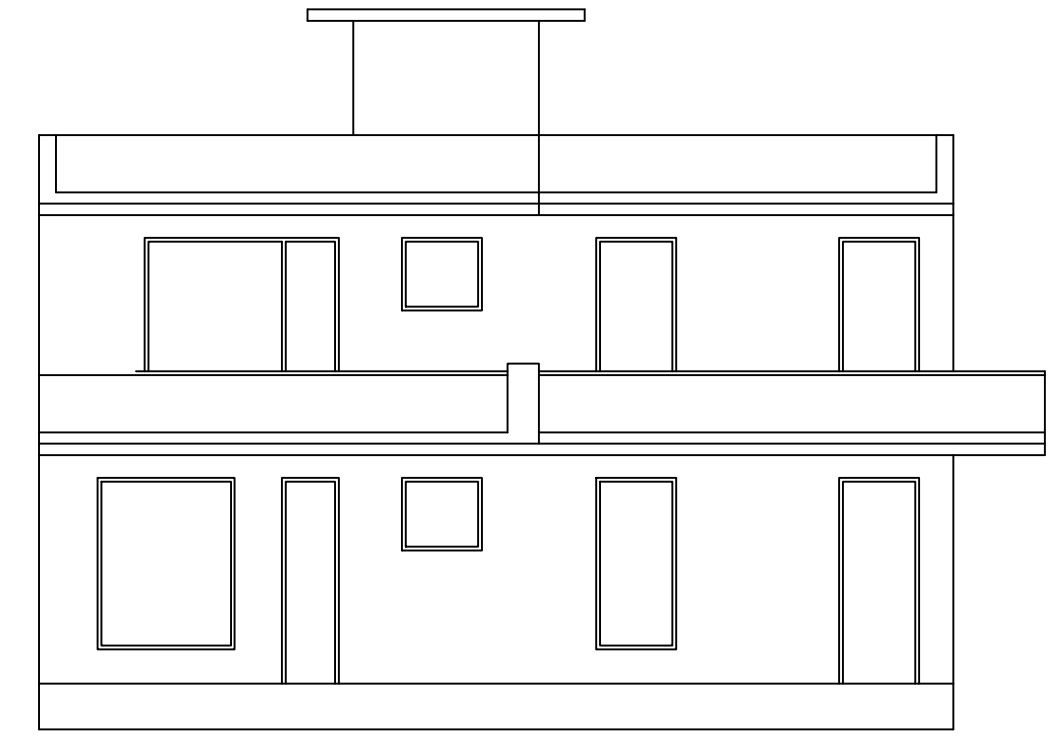

Building :A (KUSUM)

Floor Name	Gross Builtup Area	Deductions From Gross BUA/Area in Sq.mt) Cutout	Total Built Up Area (Sq.mt.)	Proposed FAR Area (Sq.mt.)	Total FAR Area (Sq.mt.)	Total Consumed Additional FAR Area (Sq.mt.)	Tnmt (No.)
Ground Floor	153.92	2.92	151.00	151.00	151.00	151.00	01
First Floor	179.71	0.00	179.71	179.71	179.71	179.71	00
Terrace Floor	0.00	0.00	0.00	0.00	0.00	0.00	00
Total :	333.63	2.92	330.71	330.71	330.71	330.71	01
Total Number of Same Buildings :	1						
Total :	333.63	2.92	330.71	330.71	330.71	330.71	01

SCHEDULE OF DOOR:

BUILDING NAME	NAME	LENGTH	HEIGHT	NOS
A (KUSUM)	D2	0.75	2.10	11
A (KUSUM)	D1	0.90	2.10	05
A (KUSUM)	D	1.00	2.10	10
A (KUSUM)	MD	1.10	2.10	03

SCHEDULE OF WINDOW/VENTILATION:

BUILDING NAME	NAME	LENGTH	HEIGHT	NOS
A (KUSUM)	V	0.60	1.20	07
A (KUSUM)	W1	1.20	1.20	03
A (KUSUM)	W	1.50	1.20	14

Buildingwise Floor FAR Details

Floor Name	Building Name A (KUSUM)		Total	
	Proposed Built Up Area (Sq.mt.)	Proposed FAR Area (Sq.mt.)	Total Proposed Built Up Area (Sq.mt.)	Total FAR Area (Sq.mt.)
Ground Floor	151.00	151.00	151.00	151.00
First Floor	179.71	179.71	179.71	179.71
Terrace Floor	0.00	0.00	0.00	0.00
Total :	330.71	330.71	330.71	330.71

Building USE/SUBUSE Details

Building Name	Building Use	Building SubUse	Building Structure
A (KUSUM)	Residential	Bungalow/ Dwelling / Non Apartment	Non-Highrise

UnitBUA Table for Building :A (KUSUM)

FLOOR	Name	UnitBUA Type	UnitBUA Area	Carpet Area	No. of Rooms	No. of Tenement
GROUND FLOOR	SPLIT A	FLAT	330.71	330.63	14	1
FIRST FLOOR	SPLIT A	FLAT	0.00	0.00	18	0
Total:	-	-	330.71	330.63	32	1

FAR & Tenement Details (Table 4c-1)

Building	No. of Same Bldg	Gross Built Up Area (Sq.mt.)	Deductions From Gross BUA/Area in Sq.mt.) Cutout	Total Built Up Area (Sq.mt.)	Proposed FAR Area (Sq.mt.)	Total FAR Area (Sq.mt.)	Total Consumed Additional FAR Area (Sq.mt.)	Tnmt (No.)
A (KUSUM)	1	333.63	2.92	330.71	330.71	330.71	330.71	01
Grand Total :	1	333.63	2.92	330.71	330.71	330.71	330.71	01

COLOR INDEX

PLOT BOUNDARY	Black
ABUTTING ROAD	Green
PROPOSED CONSTRUCTION	Red
COMMON PLOT	Yellow
ROAD WIDENING AREA	Blue
EXISTING (To be retained)	Light Blue
EXISTING (To be demolished)	Dark Blue

LTP NAME AND SIGNATURE	STRUCTURAL ENG'S NAME AND SIGNATURE	BUILDER NAME AND SIGNATURE	DIGITAL SIGNATURE
AMRIT KUMAR MAHATO CMC/DFTM/0004/2019			