

Proposal Basic Information	
Proposal File No.	CMC/BI/0252/W07/2022
Owner Name	SHRI MITHU RAM MAHTO
Khata No	780
Plot No	1204
Village Name	Chas
Use	Residential
SubUse	Bungalow/ Dwelling / Non Apartment

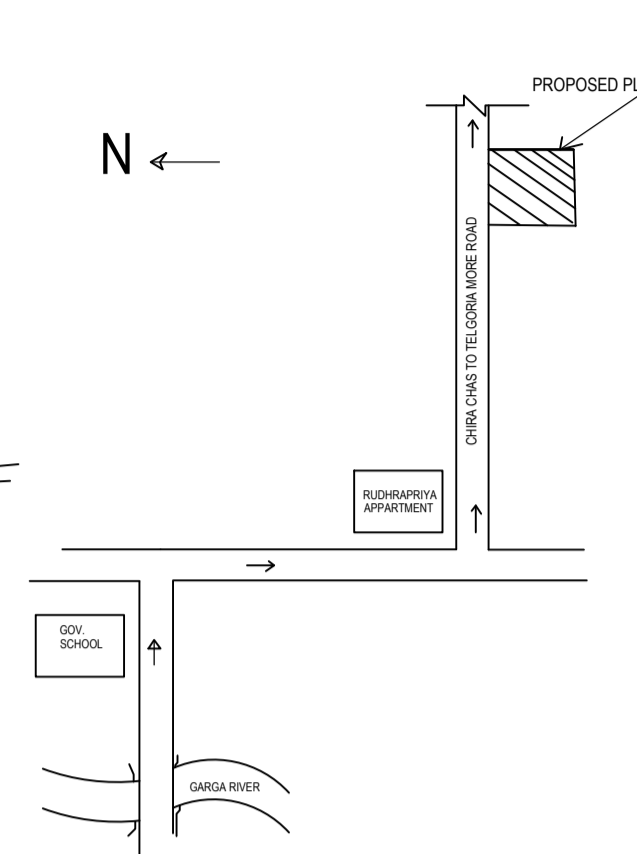

AREA STATEMENT CHAS MUNICIPAL CORPORATION		VERSION NO.: 1.0.64	SQ.MT.
PROJECT DETAIL:		VERSION DATE: 16/10/2020	
Region: JHARKHAND URBAN	Plot Use: Residential		
LOCAL BODIES: District: BOKARO	Plot SubUse: Bungalow/ Dwelling / Non Apartment		
Authority: CHAS MUNICIPAL CORPORATION	PlotNearbyReligiousStructure: NA		
Inward_No: CMC/BI/0252/W07/2022	Plot/SubPlot No: 1204		
Application Type: General Proposal	North: Road Width - 12.1 MTR		
Project Type: Building Permission	South: Plot No. - 1202		
Nature of Development: New	East: CTS No. - SHRI JHAGRU KUMHAR		
Location of Development Area: Old Area	West: CTS No. - SHRI YAMUNA PRASAD		
AREA OF PLOT (Minimum)	(A)	317.20	
NET AREA OF PLOT(Gross Plot Area - Deduction from Gross Plot Area)	(A-Deductions)	317.20	
Deduction for Balance Plot Area(from Gross Plot Area)			
Common Plot		16.69	
Total		16.69	
BALANCE AREA OF PLOT(Net Plot Area - Recreational/Amenity space)	(A-Deductions)	300.52	
PLOT AREA FOR COVERAGE(Net Plot Area)	(A-Deductions)	317.20	
Plot Area for FAR (Net Plot Area - Road/Widening Area)	(A-Deductions)	317.20	
COVERAGE CHECK			
Permissible Coverage area (60.00 %)		190.32	
Proposed Coverage Area (59.97 %)		190.22	
Total Prop. Coverage Area (59.97 %)		190.22	
Balance coverage area (0.03 %)		0.10	
FAR CHECK			
Perm. FAR Area (2.50)		793.00	
Total Perm. FAR area		793.00	
Residential FAR		200.95	
Proposed FAR Area		218.02	
Total Proposed FAR Area		218.02	
Consumed FAR (Factor)		0.69	
Balance FAR Area		574.98	
BUILT UP AREA CHECK			
Total Proposed BuiltUp Area		392.94	
ARCHITECT (Regd)		SUBHASH NARHARRAO NETRAGONKAR	
ENGINEER (Regd)			
SUPERVISOR (Regd)			
OWNER (Regd)		SHRI MITHU RAM MAHTO	
DEVELOPMENT AUTHORITY			LOCAL BODY

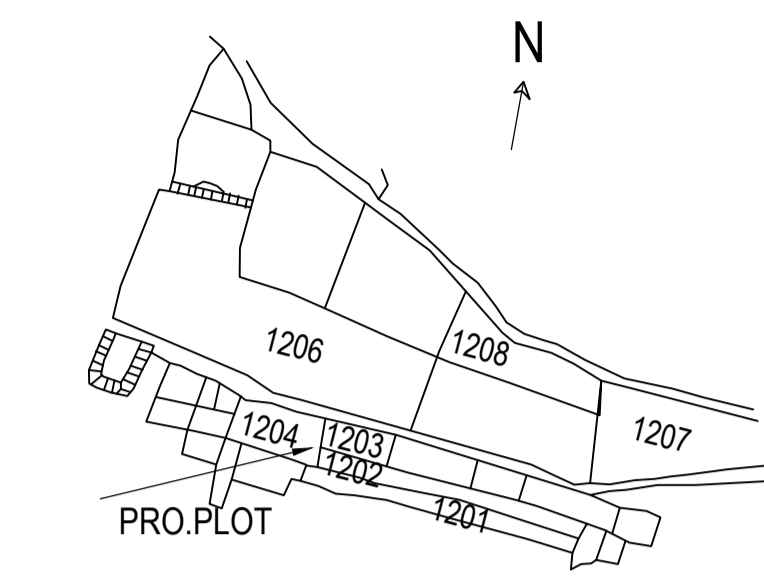
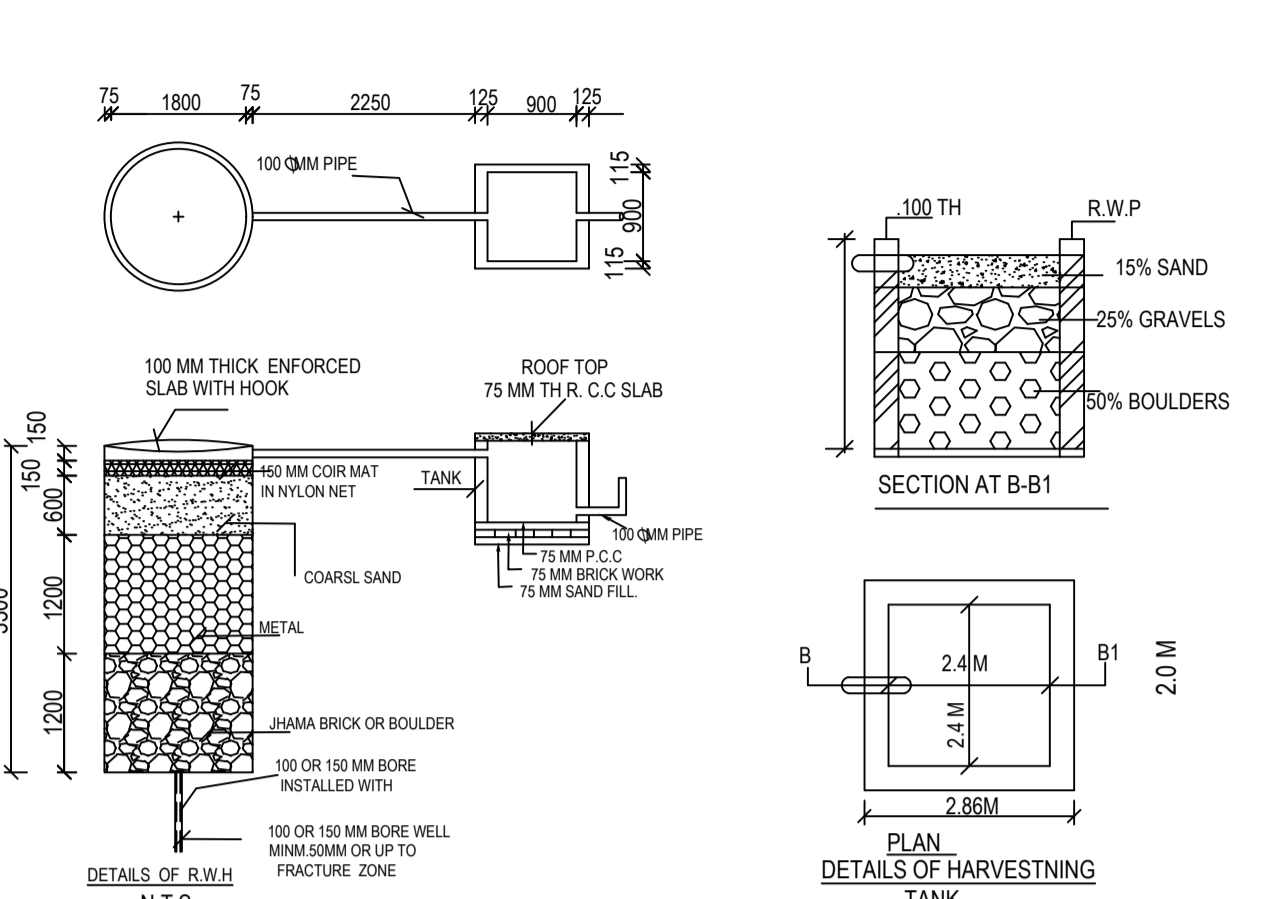
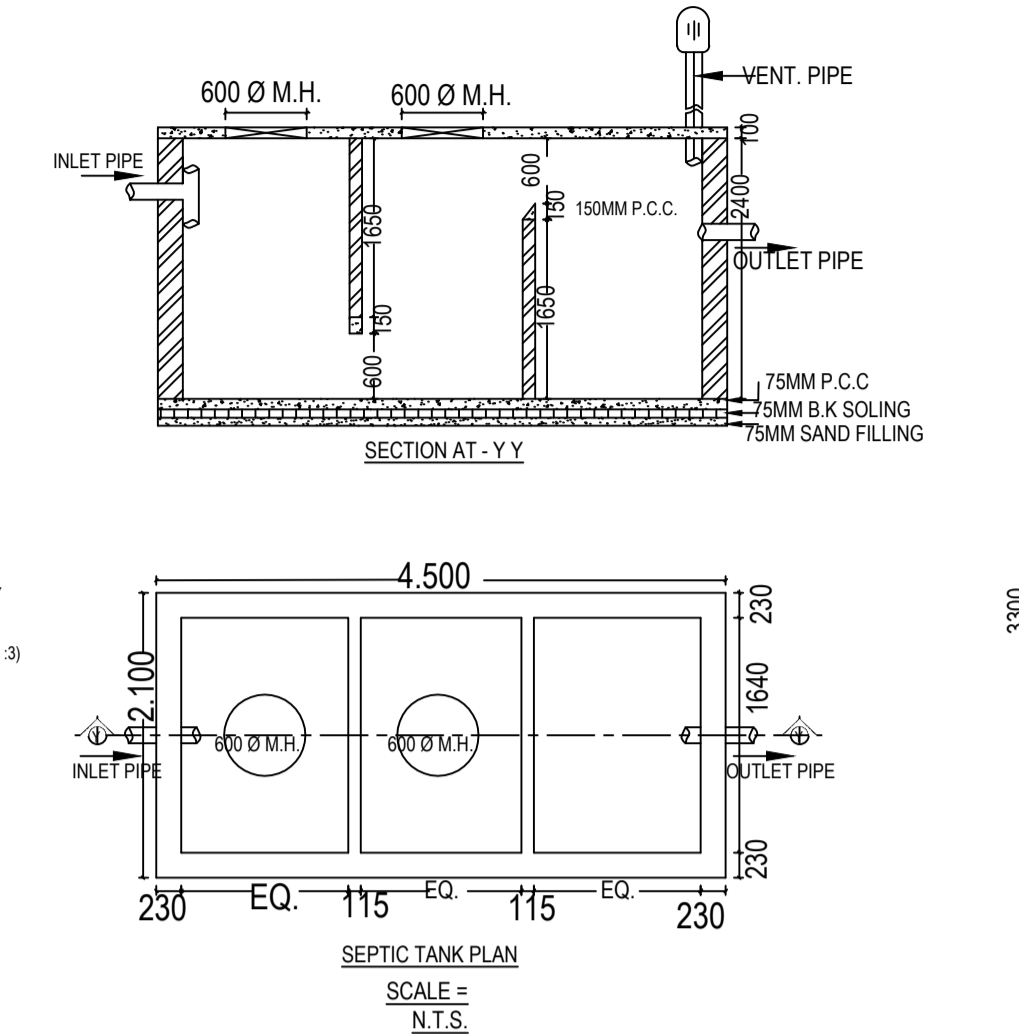
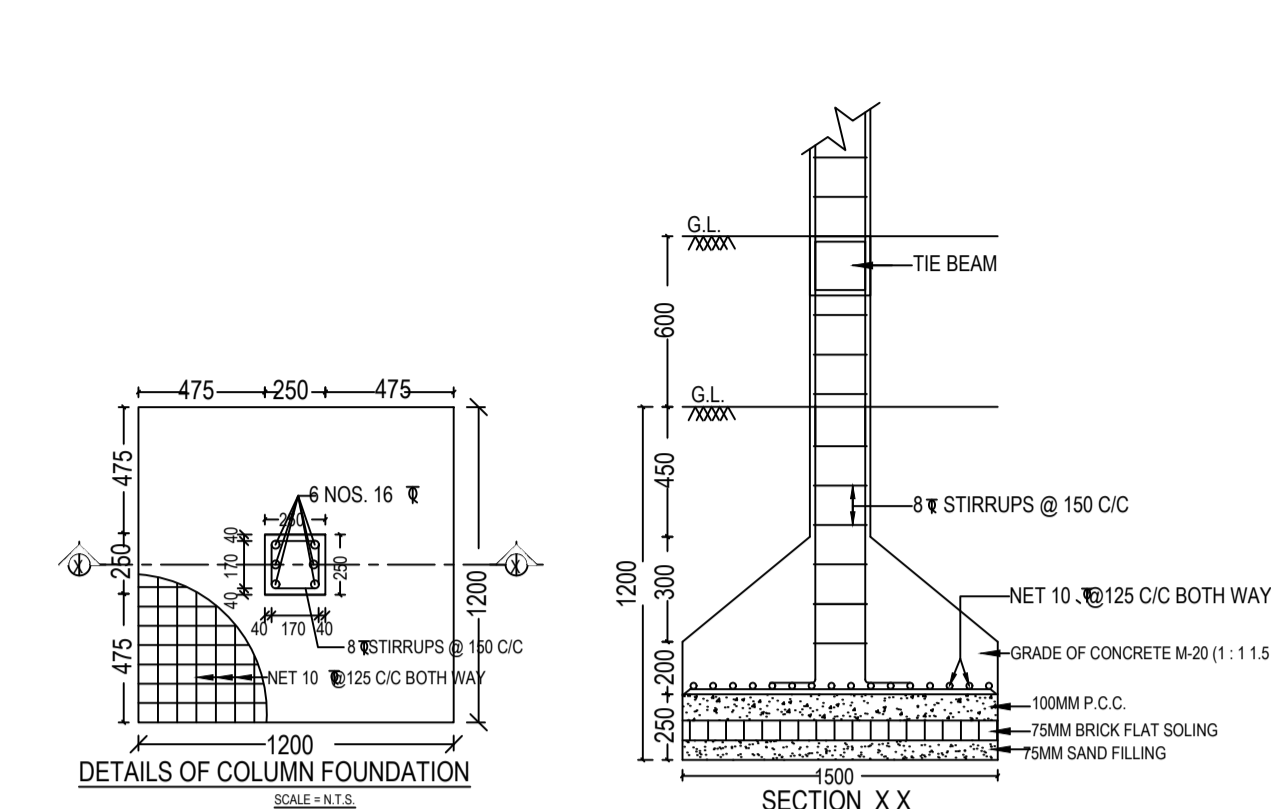
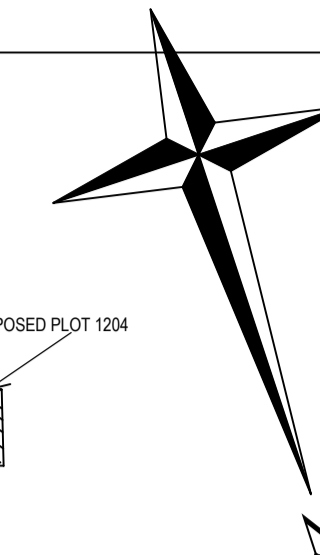
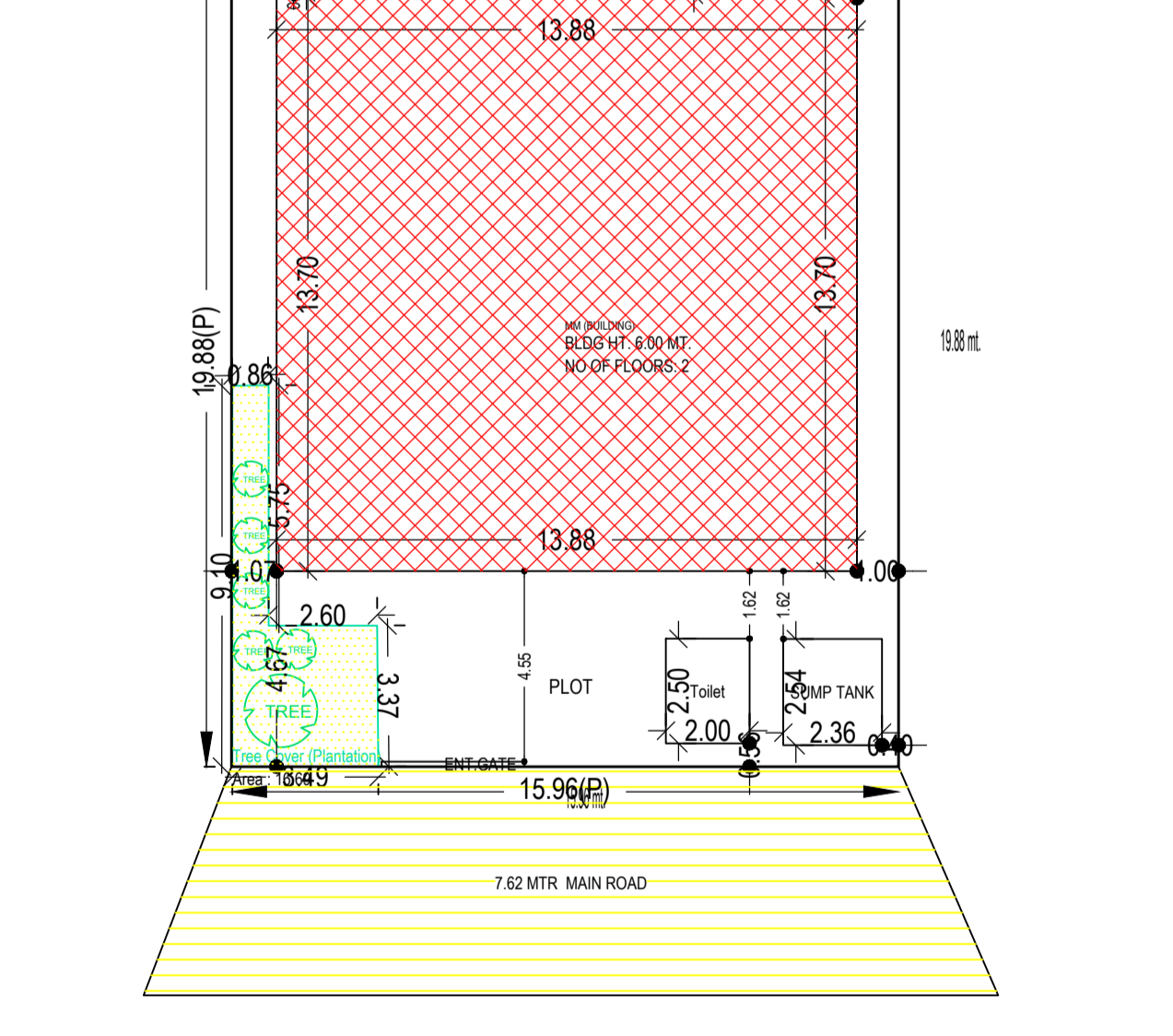
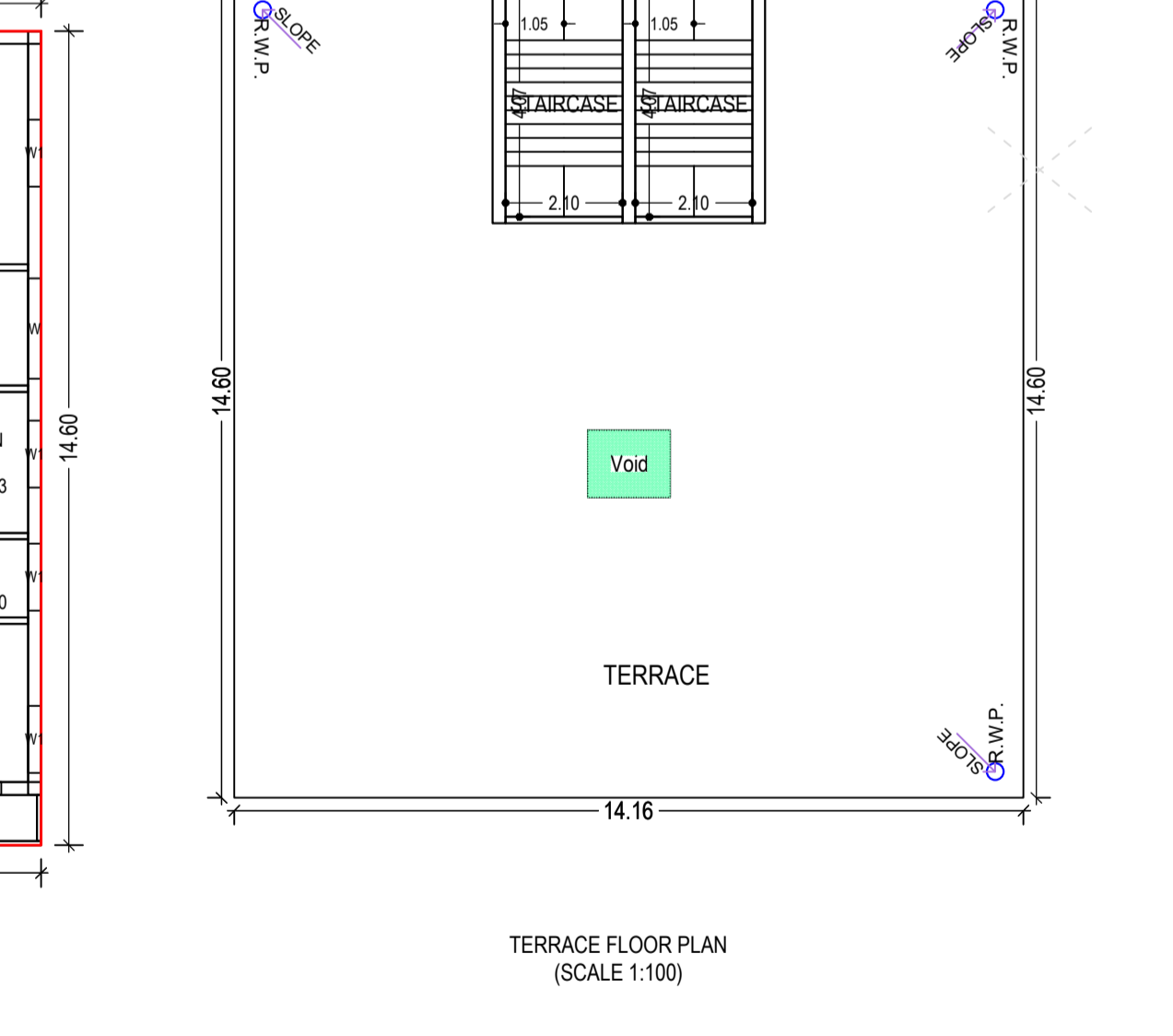
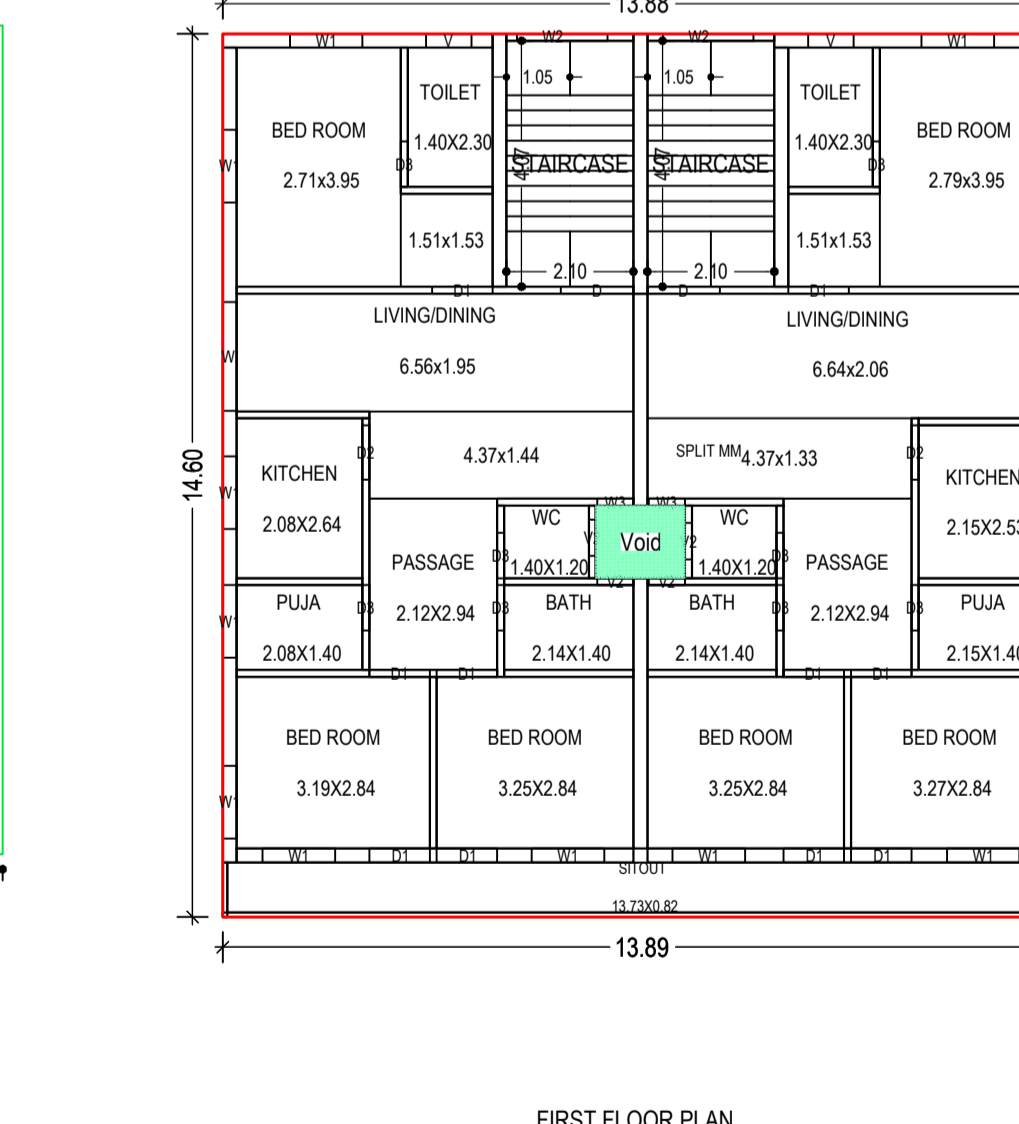
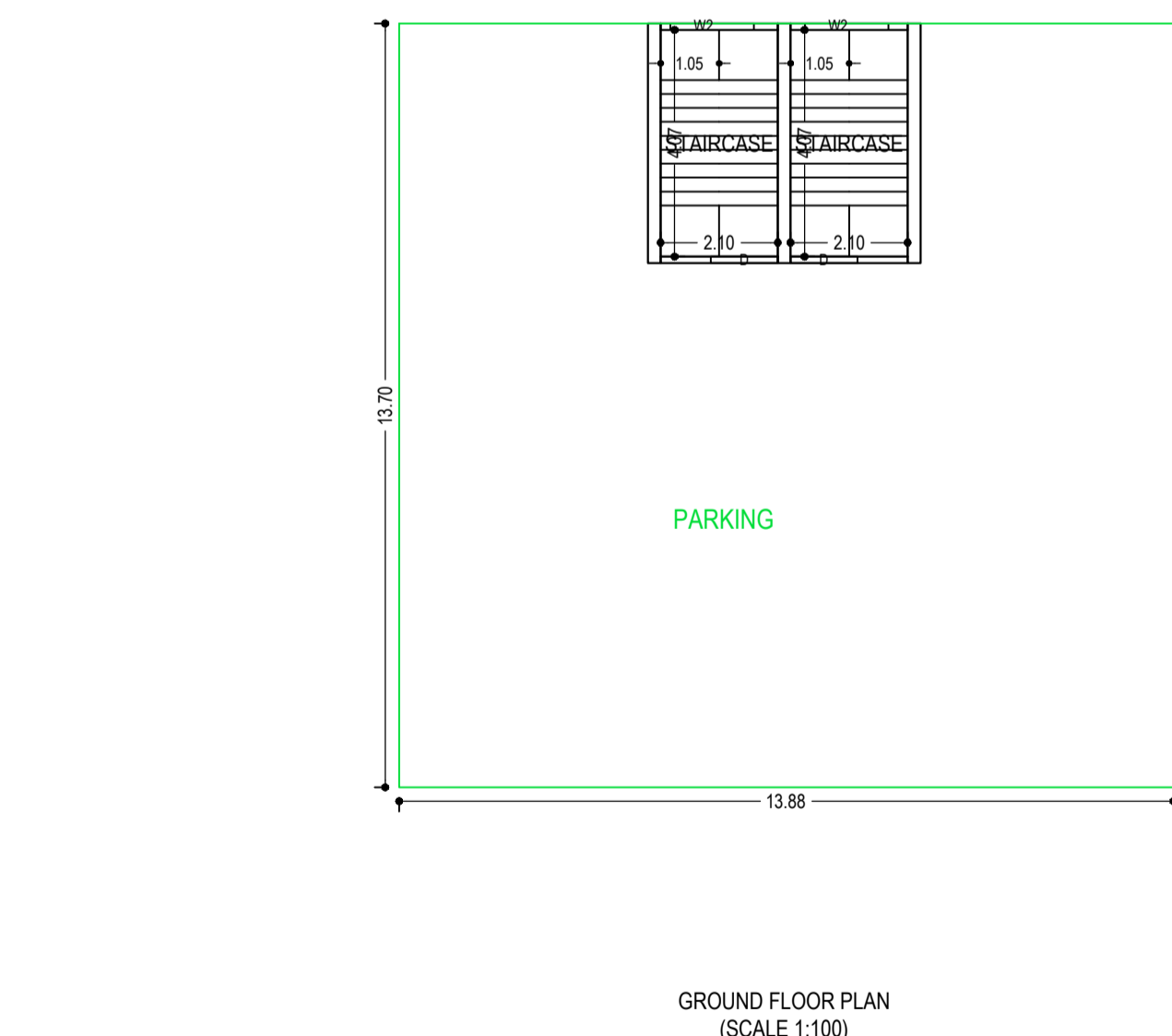
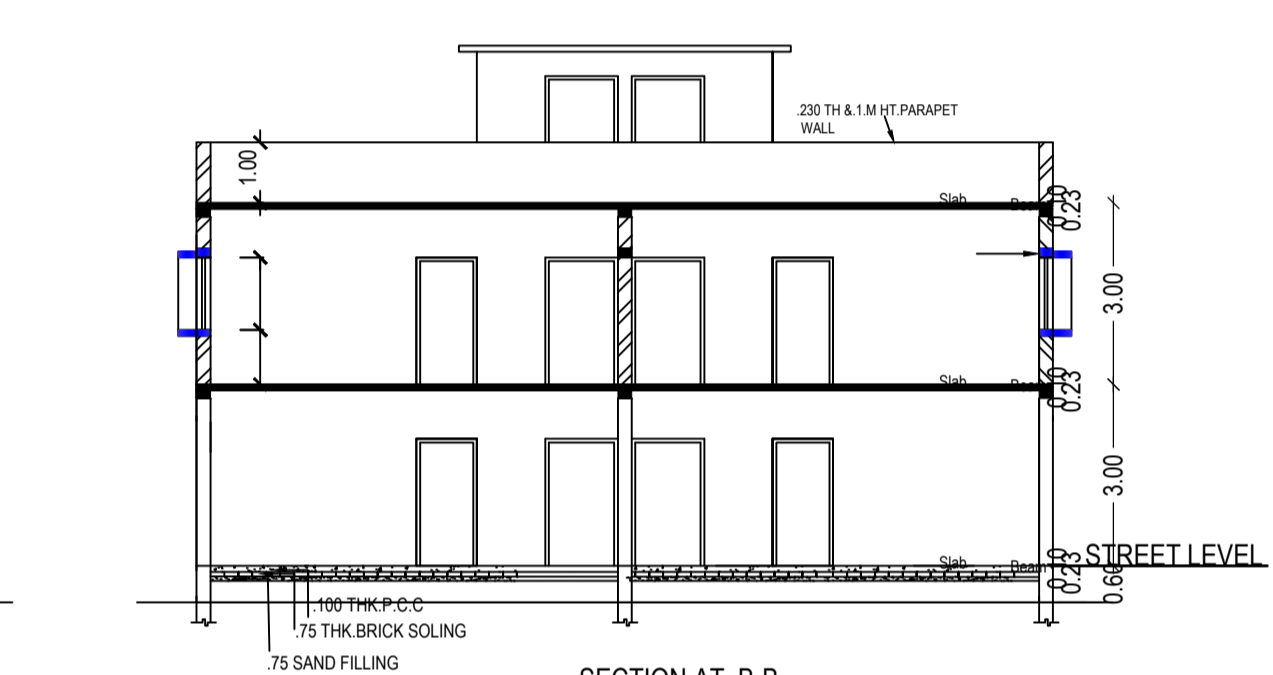
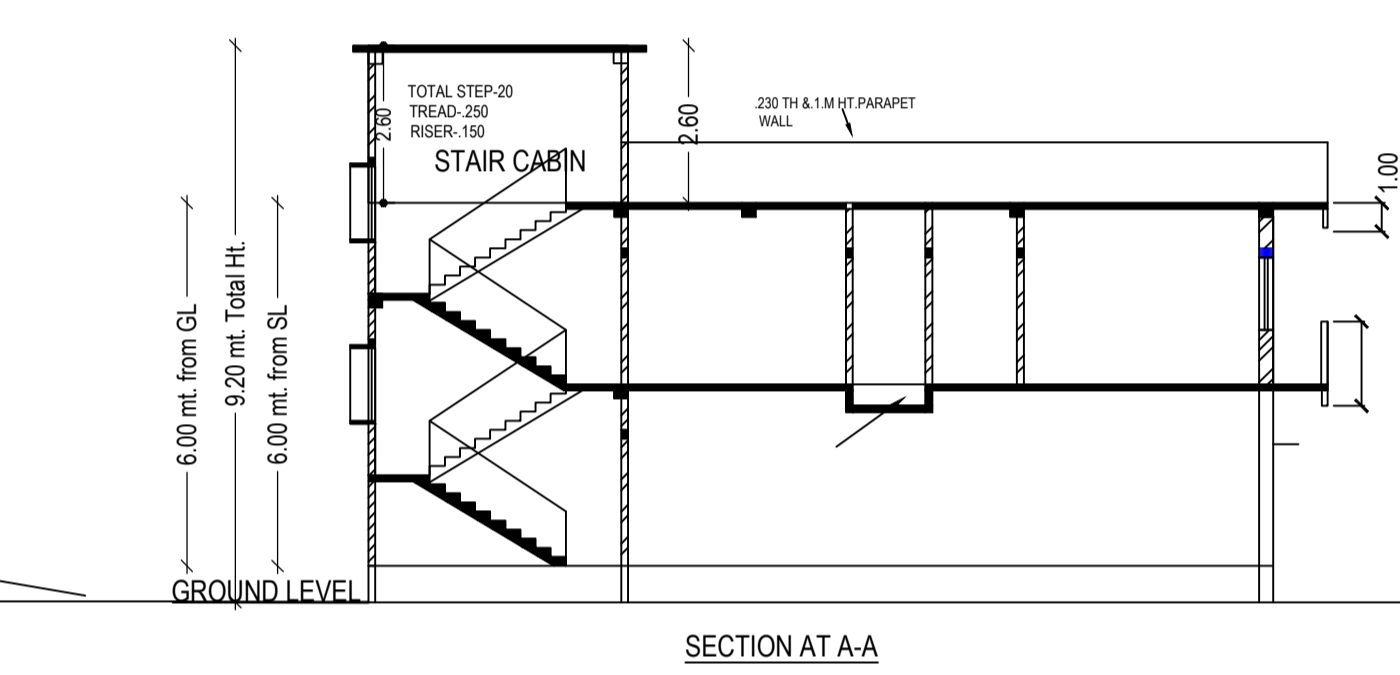
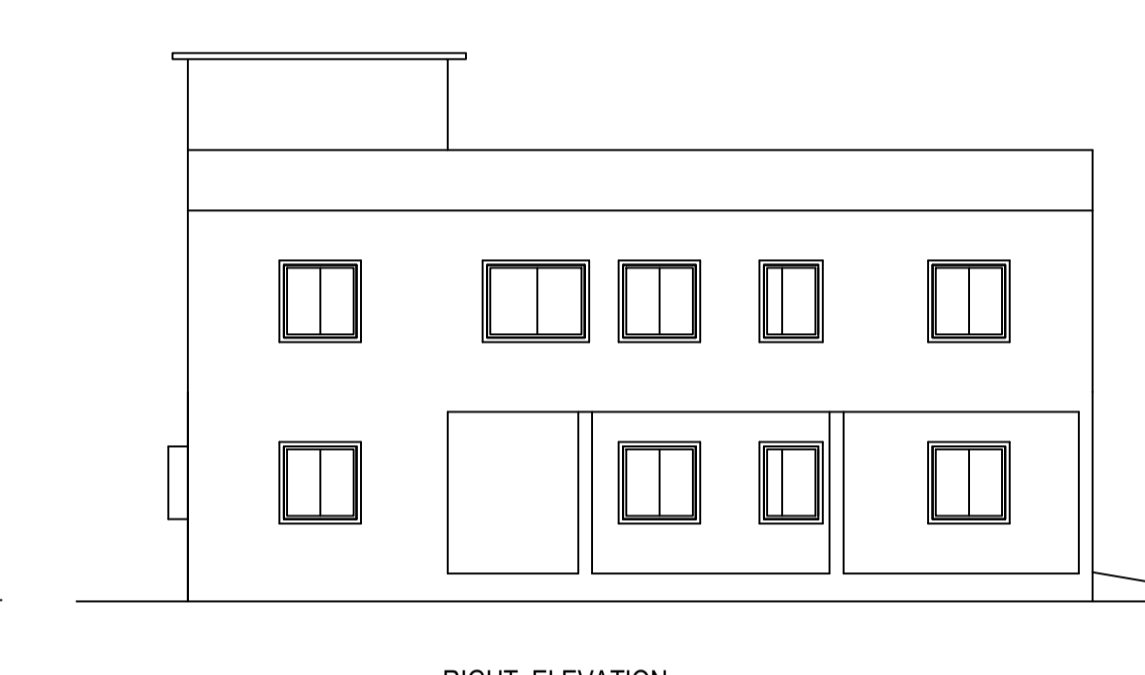
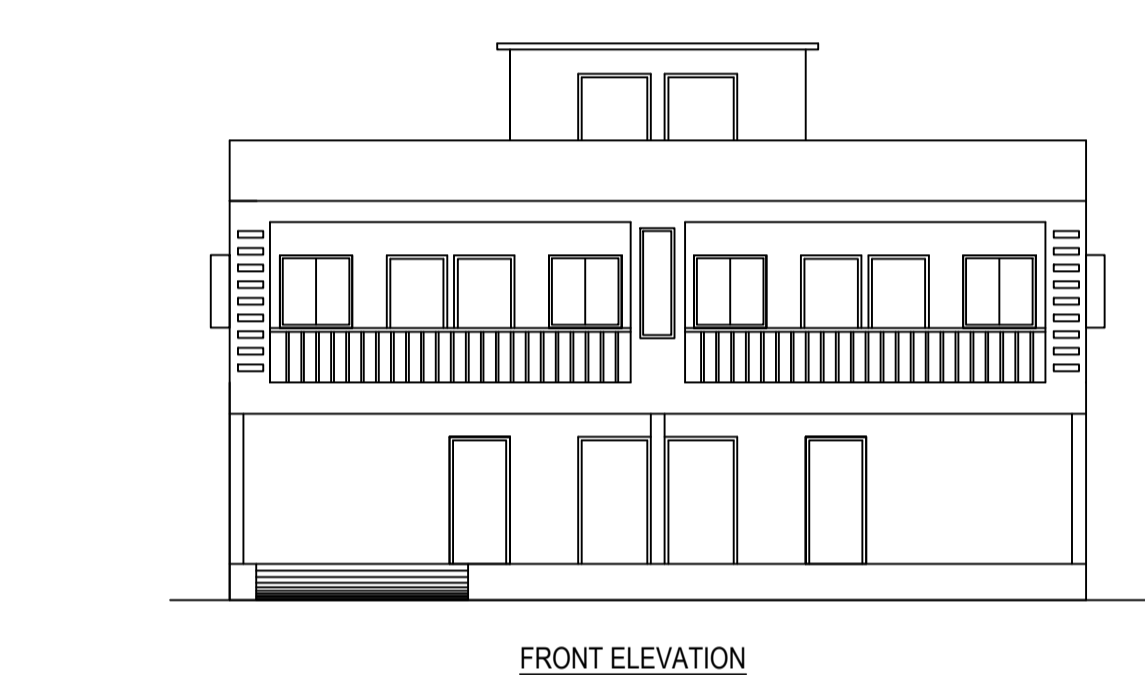

FLOOR	Name	UnitBUA Type	UnitBUA Area	Carpet Area	No. of Rooms	No. of Tenement
FIRST FLOOR PLAN	SPLIT MM	FLAT	170.58	160.34	21	1
Total:	-	-	170.58	160.34	21	1

Building	No. of Same Bldg	Total Built Up Area (Sq.mt.)	Deductions (Area in Sq.mt.)		Proposed FAR Area (Sq.mt.)		Add Area in FAR (Sq.mt.)	Total FAR Area (Sq.mt.)	Total Consumed Additional FAR Area (Sq.mt.)	Tnmt (No.)
			Void	Parking	Resi.	Stair				
MM (BUILDING)	1	392.94	1.77	173.15	200.95	17.07	218.02	218.02	218.02	01
Grand Total	1	392.94	1.77	173.15	200.95	17.07	218.02	218.02	218.02	01

Floor Name	Building Name		Total	
	Proposed Built Up Area (Sq.mt.)	Proposed FAR Area (Sq.mt.)	Total Proposed Built Up Area (Sq.mt.)	Total FAR Area (Sq.mt.)
Ground Floor	190.22	17.07	190.22	17.07
First Floor	202.72	200.95	202.72	200.95
Terrace Floor	0.00	0.00	0.00	0.00
Total :	392.94	218.02	392.94	218.02

PLOT BOUNDARY	Black
ABUTTING ROAD	Red
PROPOSED CONSTRUCTION	Green
COMMON PLOT	Blue
ROAD WIDENING AREA	Yellow
EXISTING (To be retained)	Light Blue
EXISTING (To be demolished)	Light Green

LTP NAME AND SIGNATURE	STRUCTURAL ENG'S NAME AND SIGNATURE	BUILDER NAME AND SIGNATURE	DIGITAL SIGNATURE
SUBHASH NARHARRAO NETRAGONKAR CMC/ARC/0014/2018			

Floor Name	Total Built Up Area (Sq.mt.)	Deductions (Area in Sq.mt.)	Proposed FAR Area (Sq.mt.)	Add Area in FAR (Sq.mt.)	Total FAR Area (Sq.mt.)	Total Consumed Additional FAR Area (Sq.mt.)	Tnmt (No.)
Ground Floor	190.22	0.00	173.15	0.00	17.07	17.07	00
First Floor	202.72	1.77	0.00	200.95	0.00	200.95	01
Terrace Floor	0.00	0.00	0.00	0.00	0.00	0.00	00
Total :	392.94	1.77	173.15	200.95	17.07	218.02	01

BUILDING NAME	NAME	LENGTH	HEIGHT	NOS
MM (BUILDING)	D3	0.75	2.10	08
MM (BUILDING)	D2	0.90	2.10	02
MM (BUILDING)	D1	1.00	2.10	10
MM (BUILDING)	D	1.20	2.10	02

BUILDING NAME	NAME	LENGTH	HEIGHT	NOS
MM (BUILDING)	V2	0.60	0.75	04
MM (BUILDING)	V3	0.60	1.50	02
MM (BUILDING)	V	0.75	0.60	02
MM (BUILDING)	W1	1.20	1.20	14
MM (BUILDING)	W2	1.50	1.20	05
MM (BUILDING)	W	1.80	1.20	02

Building Name	Building Use	Building SubUse	Building Structure
MM (BUILDING)	Residential	Bungalow/ Dwelling / Non Apartment	Non-Highrise