

Project Title: ABC

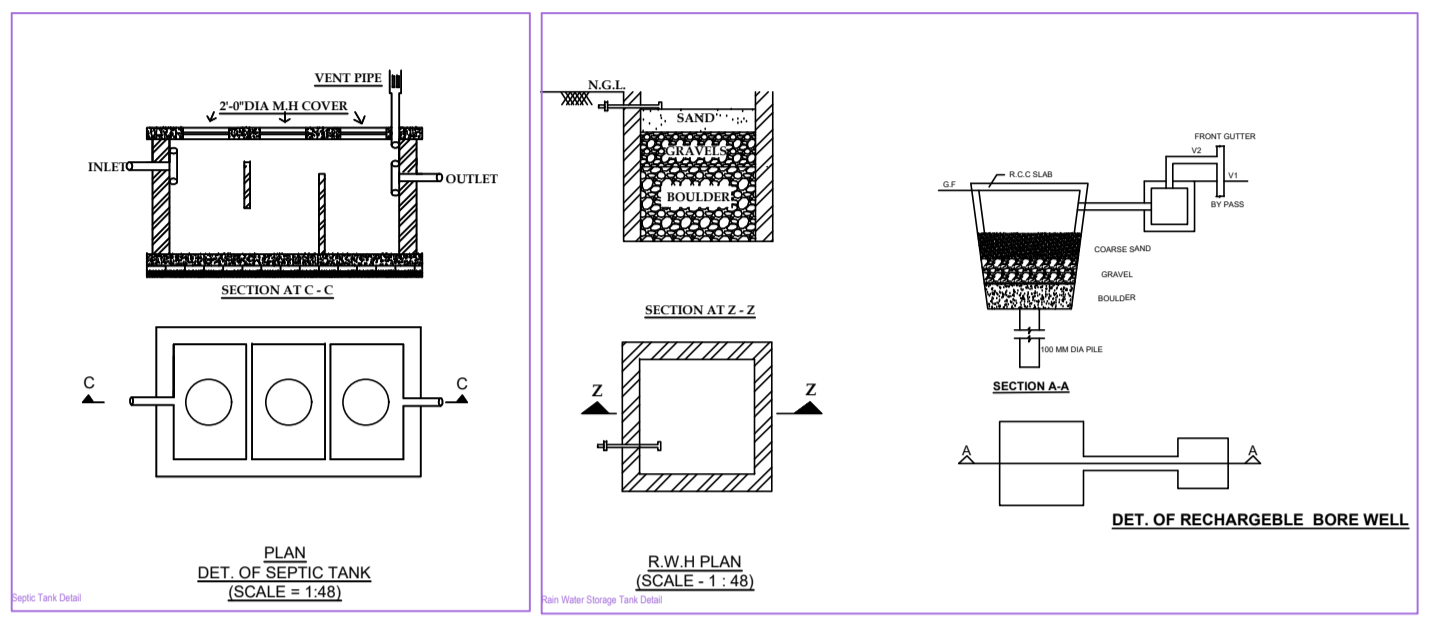
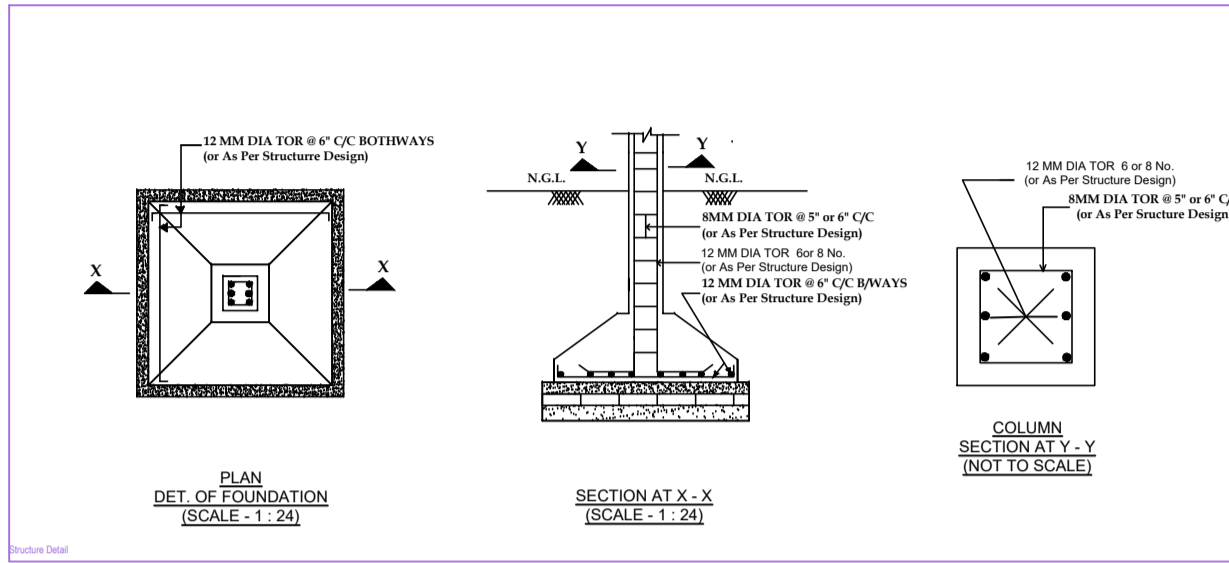

SIGN WITH SEAL BY AUTH. AUTHORITY

SPECIFICATION

1. Dimension : All dimensions are mentioned in feet & inches.
2. Excavation : As per required depth and width below the NGL.
3. Foundation : As per design of Reinforced Concrete/PCC.
4. PCC : As per M - 10 Mix Grade with 7" thickness or more.
5. DPC : As per M - 15 Mix Grade with 2" thickness or more.
6. Lined : As per M - 15 or M - 20 Mix Grade or other noted.
7. RCC : As per M - 20 or M - 25 Mix Grade or other noted.
8. SHED : As per design and FE 415 of Electrical / Tally.
9. Brick Work : First Class Brick Work with Cement Mortar 1:6 Mix in Foundation & Superstructure.
10. Plaster Work : Cement Mortar 1:3:6 in 1/2" thick on Ceiling, Outer Wall & Inner Wall respectively with 1/2" thick or noted.
11. Painting Work : White Wash / Sandesh in Outer side Wall and Colours Wash / Oil Based Emulsion in Inner side wall & Ceiling.
12. Wood Work : With Sal Wood / Teak Wood or Standard Wood.

SCHEDULE OF OPENING

Sl. No.	Description	Size	Level
1.	ROLL SHUT RIS - 6'-0"X8'-0"	15	WINDOW WY - 8'-0"X8'-0"
2.	ROLL SHUT RIS - 7'-0"X8'-0"	15	WY1 - 8'-0"X8'-0"
3.	COUP GATE GSS - 6'-0"X7'-0"	17	WY2 - 4'-0"X8'-0"
4.	CGD - 7'-0"X7'-0"	18	WINDOW WY - 6'-0"X8'-0"
5.	CGD - 6'-0"X7'-0"	19	WY1 - 6'-0"X7'-0"
6.	DOOR - 6'-0"X7'-0"	20	WY2 - 6'-0"X7'-0"
7.	DW1 - 6'-0"X8'-0"	21	WY3 - 6'-0"X8'-0"
8.	DW2 - 3'-0"X8'-0"	22	VENTILAT V - 4'-0"X8'-0"
9.	DW3 - 3'-0"X8'-0"	23	WY1 - 4'-0"X8'-0"
10.	D - 6'-0"X7'-0"	24	WY2 - 6'-0"X7'-0"
11.	D1 - 5'-0"X7'-0"	25	WY3 - 5'-0"X7'-0"
12.	D2 - 4'-0"X7'-0"	26	CHILL LEVEL - 2'-47"3'-0"
13.	D3 - 3'-0"X7'-0"	27	LOFT LEVEL - 7'-47"3'-0"
14.	D4 - 2'-0"X7'-0"	28	ROOF LEVEL - 7'-47"3'-0"

SCHEDULE OF AREA

Sl. No.	Description	Area (Sq. Ft.)
1.	BUILT UP IN FLOOR	201.778
2.	TOTAL FLOOR AREA	201.778
3.	BUILT UP IN FLOOR	488.000
4.	TOTAL FLOOR AREA	488.000
5.	BUILT UP IN FLOOR	100.000
6.	TOTAL FLOOR AREA	100.000
7.	BUILT UP IN FLOOR	100.000
8.	TOTAL FLOOR AREA	100.000
9.	BUILT UP IN FLOOR	100.000
10.	TOTAL FLOOR AREA	100.000

Wani Design & Construction  
 PROPOSED RESIDENTIAL BUILDING NEAR CHICK POST CHAN, BOKARD -  
 MISS. SANJU KUMAR, INC. AND PLOT SITUATED AT  
 VILL. - TEMAKOHO BUREND, P.O. + P.S. - JINTE - DHANBAD,  
 PIN - 808014, STATE - BIHAR

Sl. No.	Description	Area (Sq. Ft.)
1.	Ground Floor	133.34
2.	First Floor	154.66
3.	Roof Top	13.34
4.	Total Floor Area	401.34

OWNER: ARCHITECT/ENGINEER

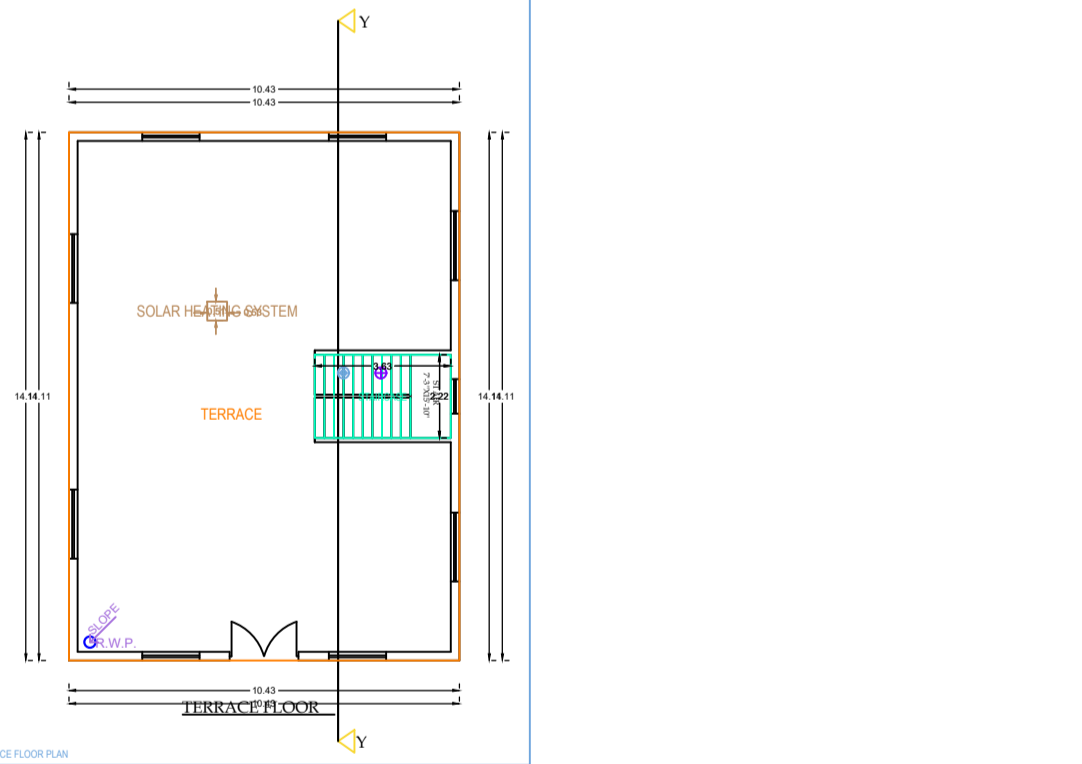
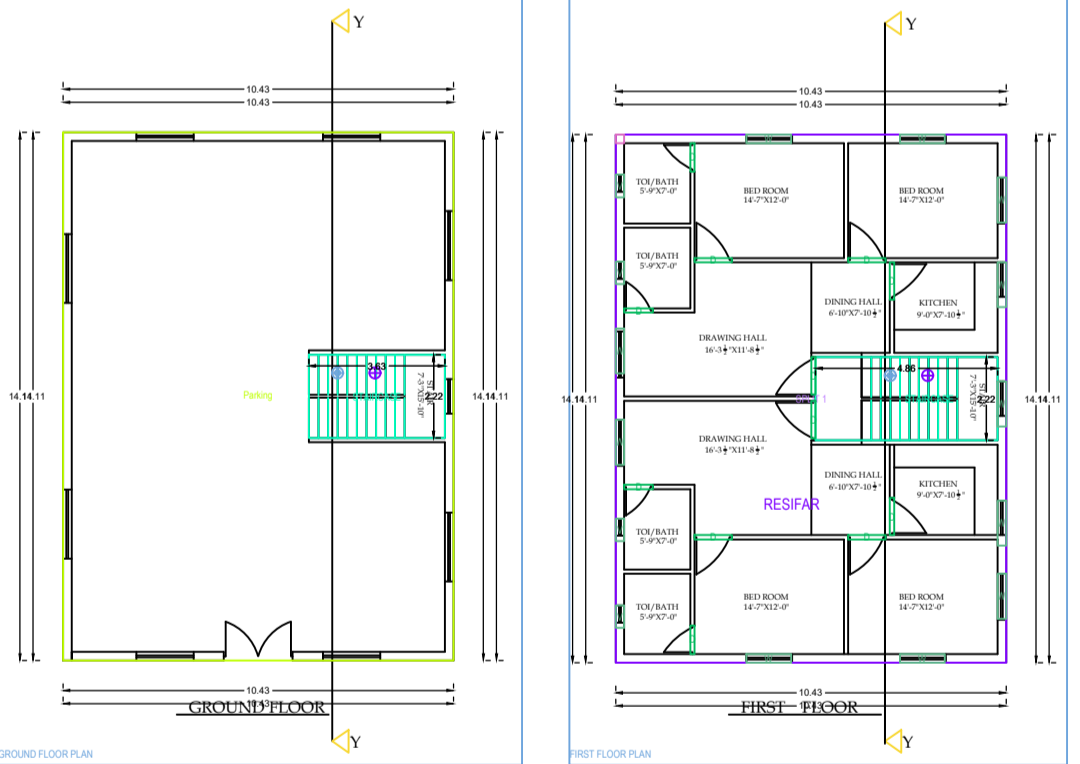
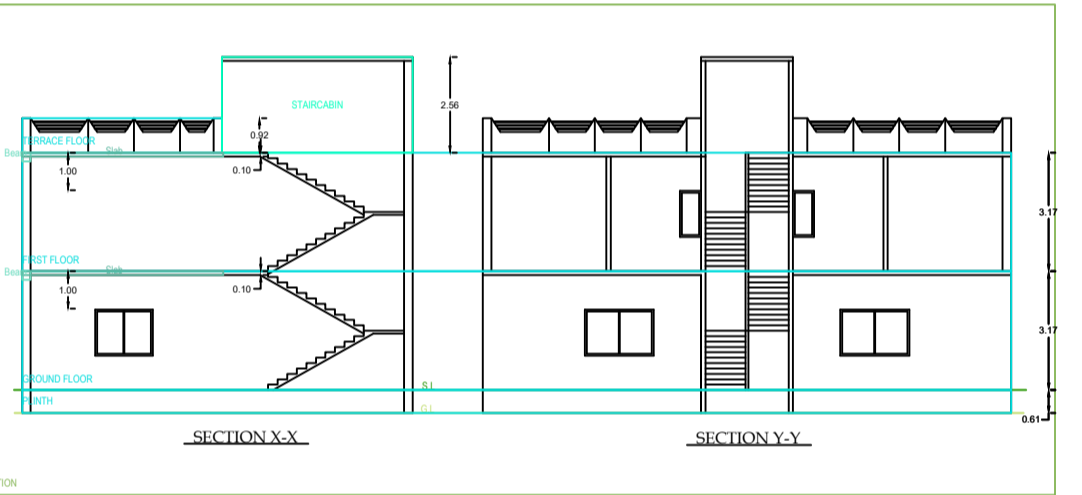
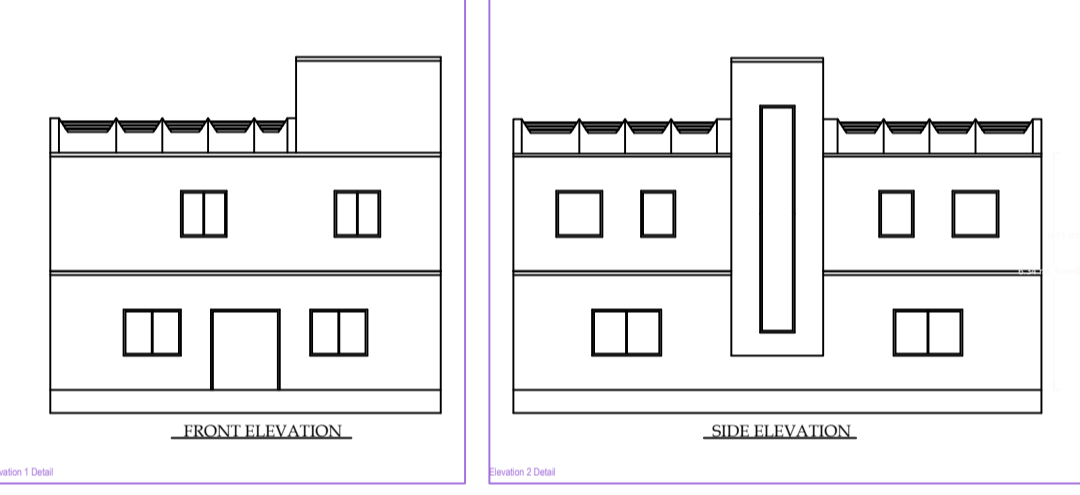
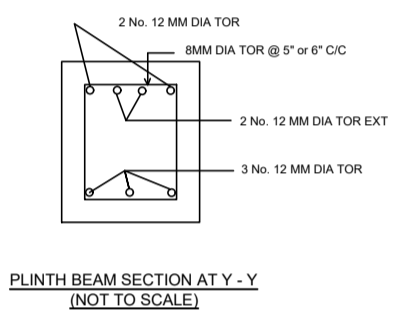
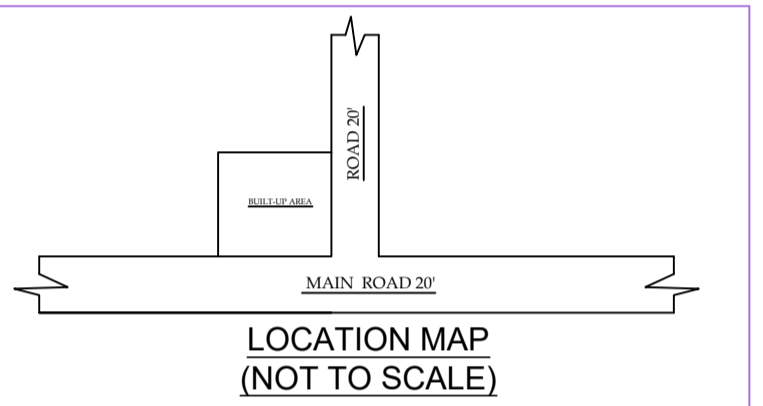
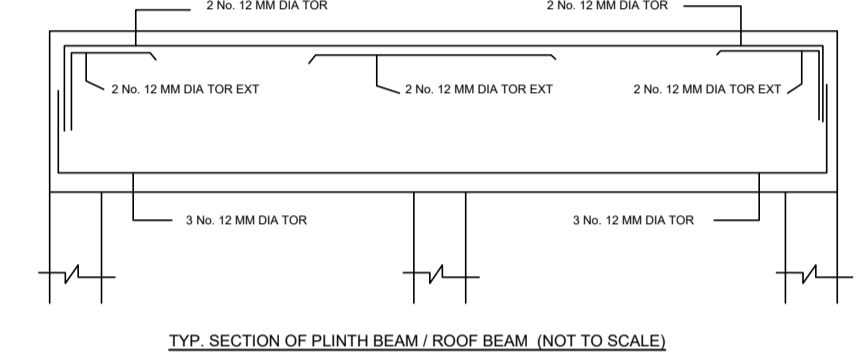

SCHEDULE OF DOORS & WINDOWS

Sl. No.	Type	Width	Height
1.	D	4'-0"	7'-0"
2.	D1	3'-0"	7'-0"
3.	D2	2'-4"	7'-0"
4.	D3	4'-0"	7'-0"
5.	D4	3'-0"	7'-0"
6.	D5	3'-0"	7'-0"
7.	D6	3'-0"	7'-0"

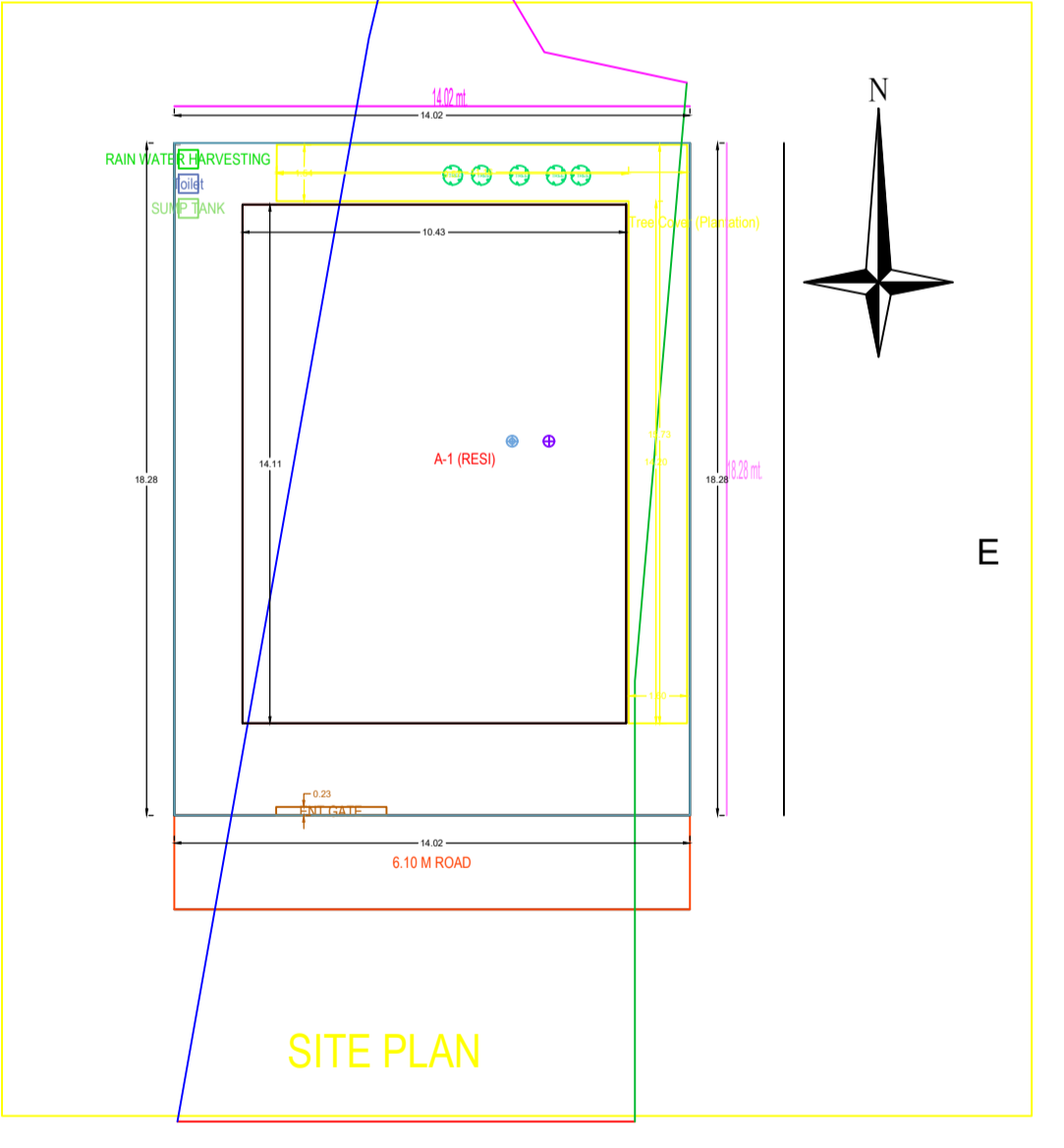

Building A (RES)

Sl. No.	Description	Area (Sq. Ft.)
1.	Ground Floor	133.34
2.	First Floor	154.66
3.	Roof Top	13.34
4.	Total Floor Area	401.34

SCHEDULE OF JOINERY

Sl. No.	Description	Area (Sq. Ft.)
1.	Window	100.00
2.	Door	100.00
3.	Roof	100.00

SCHEDULE OF JOINERY

Sl. No.	Description	Area (Sq. Ft.)
1.	Window	100.00
2.	Door	100.00
3.	Roof	100.00

UtilBUA Table for Building A (RES)

FLOOR	Name	UtilBUA Type	UtilBUA Area	UtilBUA Area	No. of Rooms	No. of Tenants
GROUND FLOOR	RESIDENTIAL	RESIDENTIAL	133.34	133.34	1	1
FIRST FLOOR	RESIDENTIAL	RESIDENTIAL	154.66	154.66	1	1
ROOF TOP	RESIDENTIAL	RESIDENTIAL	13.34	13.34	1	1