

Proposal Basic Information	
Proposal File No.	CMC/BP/0108/W04/2023
Owner Name	1.RADHIKA DEVI 2.CHANDESHWAR NONIA
Khata No	576
Plot No	1341
Village Name	Chas
Use	Residential
SubUse	Bungalow/ Dwelling / Non Apartment

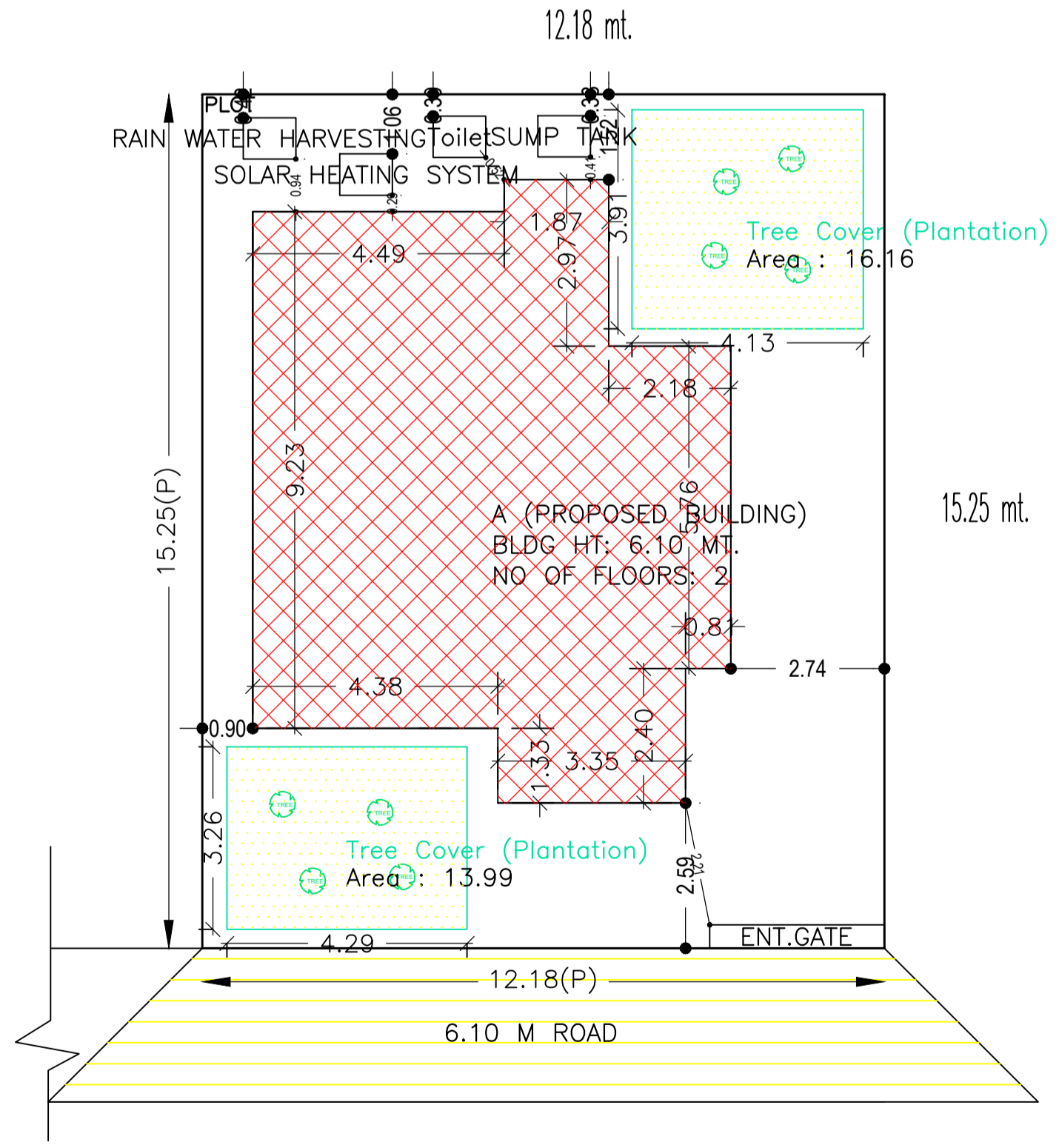
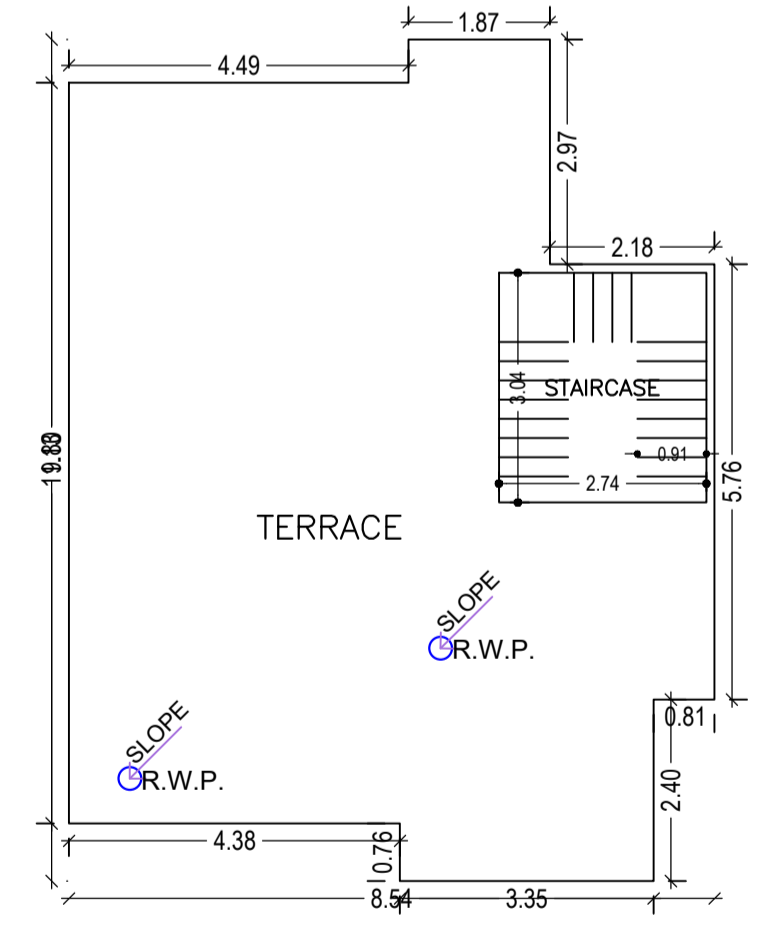
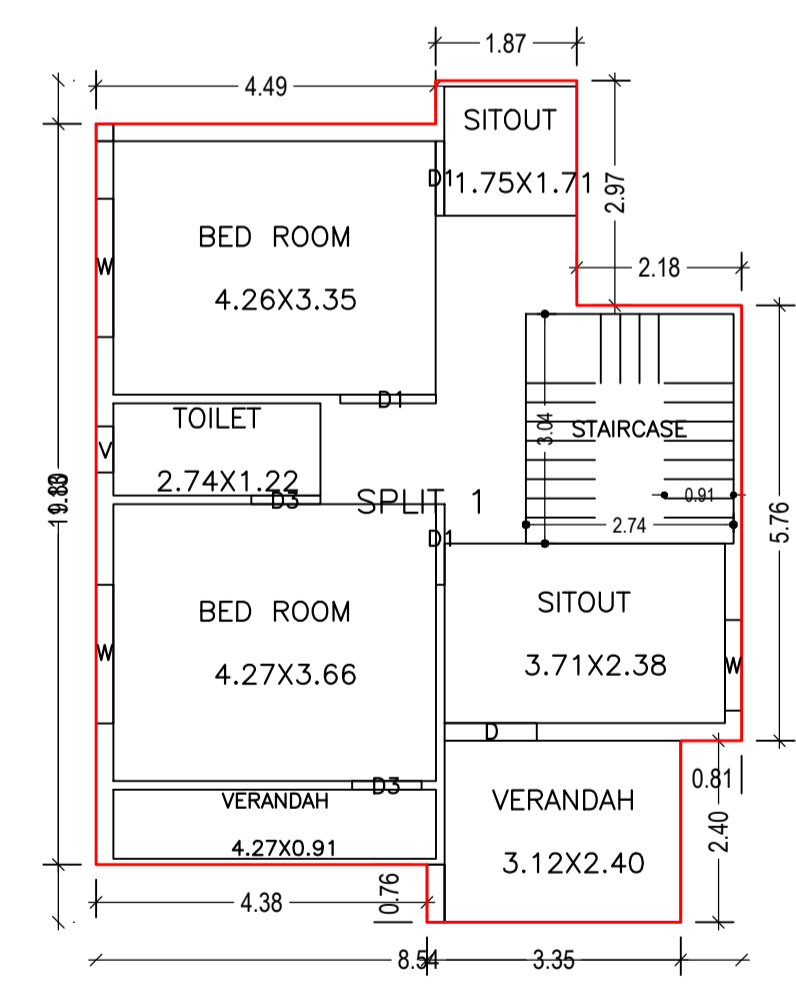
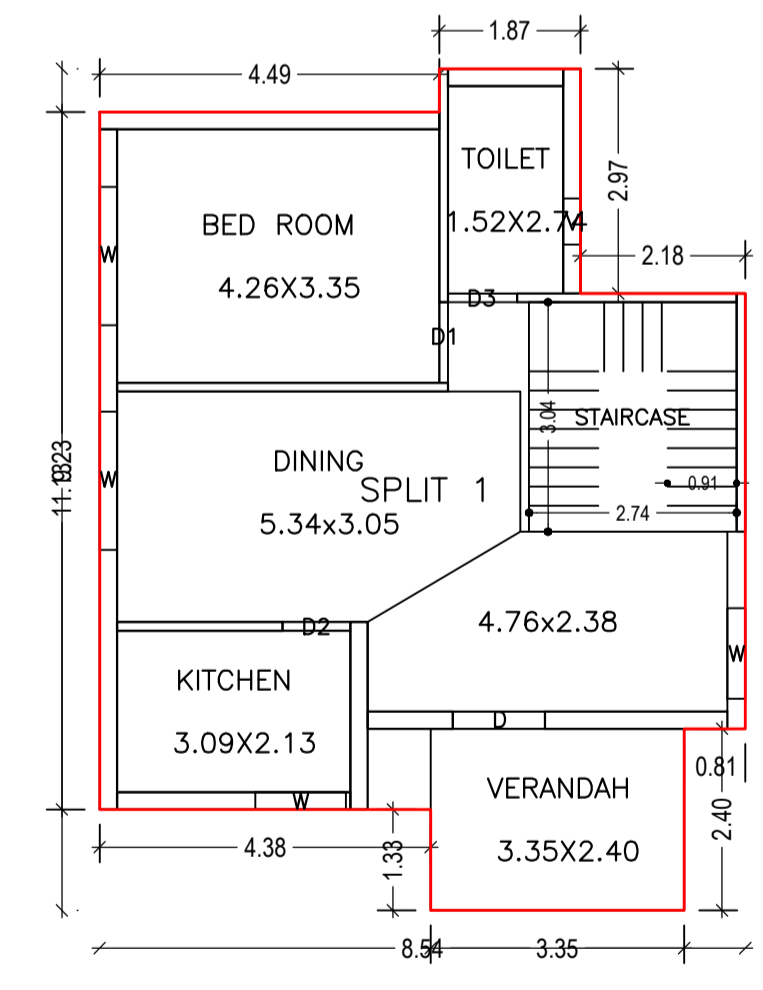
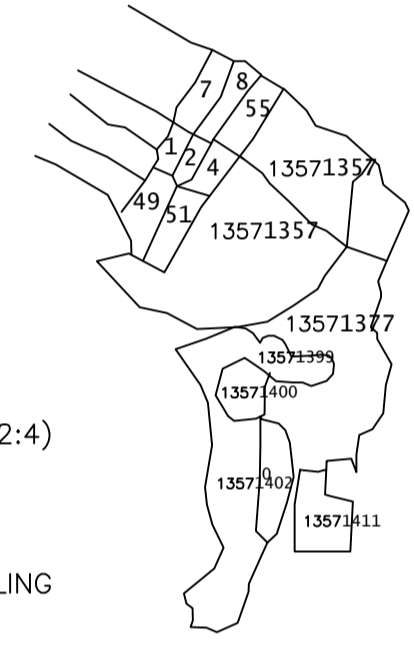
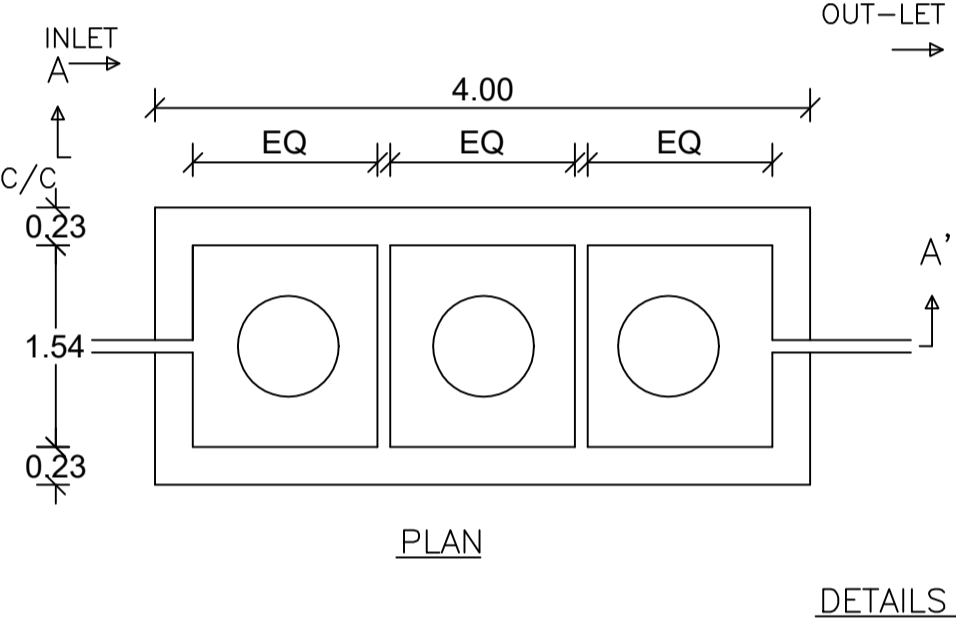
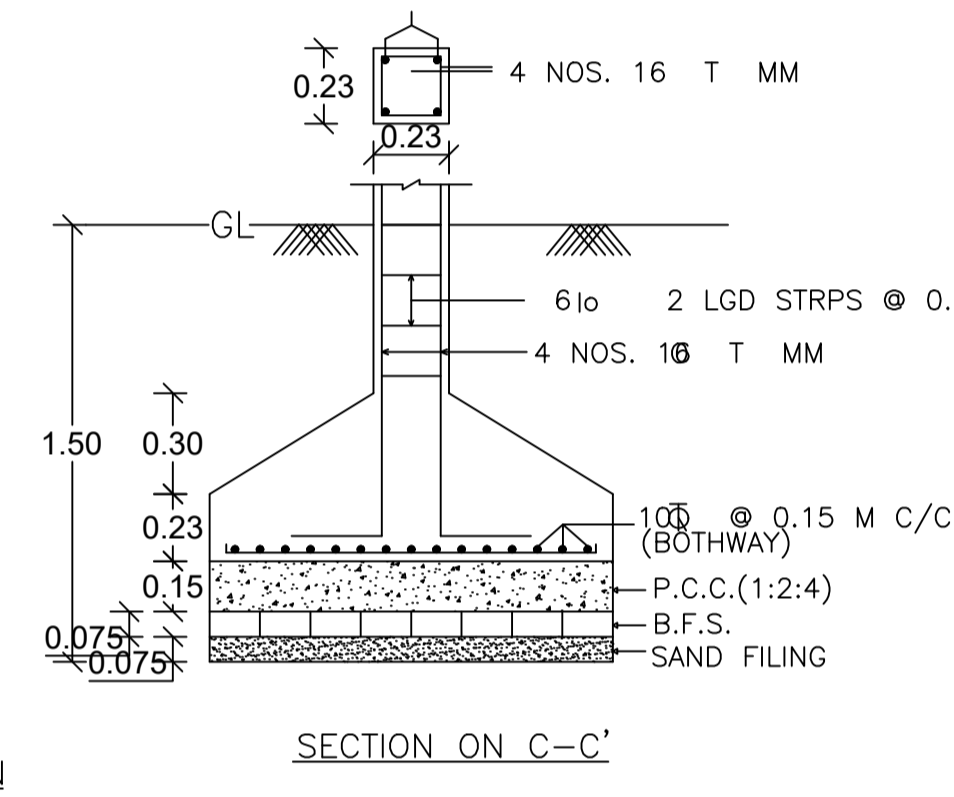
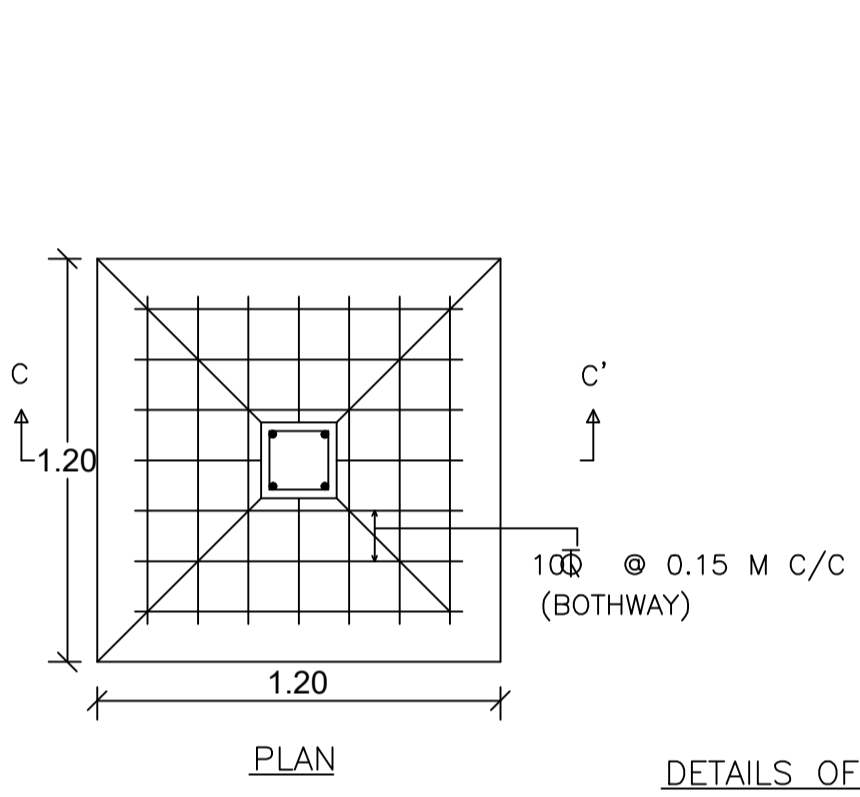
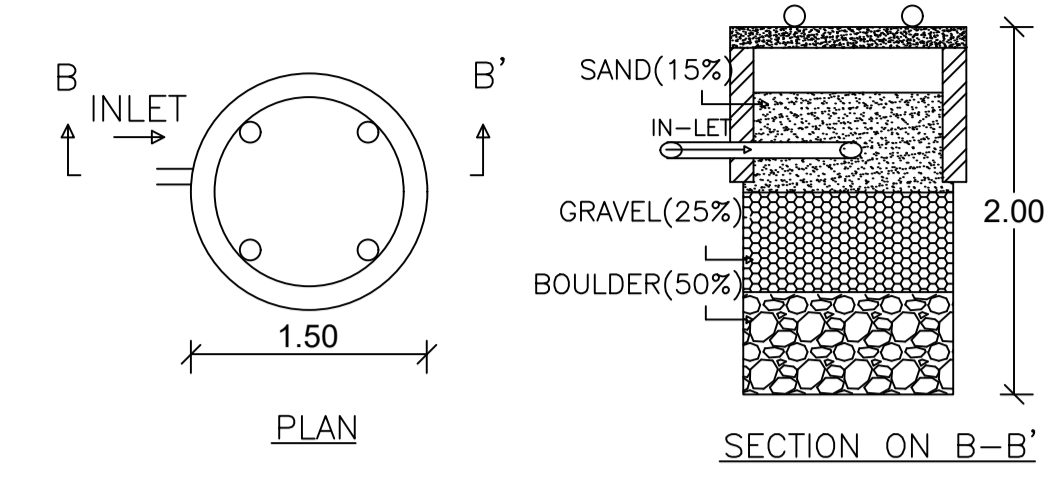

AREA STATEMENT CHAS MUNICIPAL CORPORATION		VERSION NO.: 1.0.66
		VERSION DATE: 16/10/2020
PROJECT DETAIL:		
Region: JHARKHAND URBAN LOCAL BODIES	Plot Use: Residential	
District: BOKARO	Plot SubUse: Bungalow/ Dwelling / Non Apartment	
Authority: CHAS MUNICIPAL CORPORATION	PlotNearbyReligiousStructure: NA	
Inward No: CMC/BP/0108/W04/2023	Plot/SubPlot No: 1341	
Application Type: General Proposal	North: Plot No. - PLOT NO.- 1341	
Project Type: Building Permission	South: Plot No. - PLOT NO.- 1341	
Nature of Development: New	East: Road Width - ROAD	
Location of Development Area: New Area	West: Plot No. - PLOT NO.- 1341	
AREA DETAILS:		
AREA OF PLOT (Minimum)	(A)	185.78
NET AREA OF PLOT(Gross Plot Area - Deduction from Gross Plot area)	(A-Deductions)	185.78
Deduction for Balance Plot Area(from Gross Plot Area)		
Common Plot		30.15
Total		30.15
BALANCE AREA OF PLOT(Net Plot Area - Recreational/Amenity space)	(A-Deductions)	155.63
PLOT AREA FOR COVERAGE(Net Plot Area)	(A-Deductions)	185.78
Plot Area for FAR (Net Plot Area + RoadWidening Area)	(A-Deductions)	185.78
COVERAGE CHECK		
Permissible Coverage area (70.00 %)		130.05
Proposed Coverage Area (42.10 %)		78.22
Total Prop. Coverage Area (42.1 %)		78.22
Balance coverage area (27.90 %)		51.83
FAR CHECK		
Perm. FAR Area (2.000)		371.56
Total Perm. FAR area		371.56
Residential FAR		158.95
Proposed FAR Area		158.95
Total Proposed FAR Area		158.95
Consumed FAR (Factor)		0.86
Balance FAR Area		212.61
BUILT UP AREA CHECK		
Total Proposed BuiltUp Area		158.95
ARCHITECT (Regd)	AMRIT KUMAR MAHATO	
ENGINEER (Regd)		
SUPERVISOR (Regd)		
OWNER (Regd)	1.RADHIKA DEVI 2.CHANDESHWAR NONIA	
DEVELOPMENT AUTHORITY		LOCAL BODY

SCHEDULE OF DOOR:				
BUILDING NAME	NAME	LENGTH	HEIGHT	NOS
A (PROPOSED BUILDING)	D2	0.90	2.10	01
A (PROPOSED BUILDING)	D3	0.91	2.10	03
A (PROPOSED BUILDING)	D1	0.99	2.10	01
A (PROPOSED BUILDING)	D1	1.07	2.10	02
A (PROPOSED BUILDING)	D	1.22	2.10	02
A (PROPOSED BUILDING)	D1	1.26	2.10	01

SCHEDULE OF WINDOW/VENTILATION:				
BUILDING NAME	NAME	LENGTH	HEIGHT	NOS
A (PROPOSED BUILDING)	V	0.61	1.20	02
A (PROPOSED BUILDING)	W	1.20	1.20	03
A (PROPOSED BUILDING)	W	1.83	1.20	04

UnitBUA Table for Building : A (PROPOSED BUILDING)						
FLOOR	Name	UnitBUA Type	UnitBUA Area	Carpet Area	No. of Rooms	No. of Tenement
GROUND FLOOR PLAN	SPLIT 1	FLAT	158.95	150.73	5	1
FIRST FLOOR PLAN	SPLIT 1	FLAT	0.00	0.00	7	0
Total:	-	-	158.95	150.73	12	1

FAR & Tenement Details (Table 4c-1)						
Building	No. of Same Bldg	Total Built Up Area (Sq.mt.)	Proposed FAR Area (Sq.mt.)	Total FAR Area (Sq.mt.)	Total Consumed Additional FAR Area (Sq.mt.)	Tnmt (No.)
A (PROPOSED BUILDING)	1	158.95	158.95	158.95	158.95	01
Grand Total:	1	158.95	158.95	158.95	158.95	01

Buildingwise Floor FAR Details				
Floor Name	A (PROPOSED BUILDING)		Total	
	Proposed Built Up Area (Sq.mt.)	Proposed FAR Area (Sq.mt.)	Total Proposed Built Up Area (Sq.mt.)	Total FAR Area (Sq.mt.)
Ground Floor	78.22	78.22	78.22	78.22
First Floor	80.73	80.73	80.73	80.73
Terrace Floor	0.00	0.00	0.00	0.00
Total:	158.95	158.95	158.95	158.95

Building :A (PROPOSED BUILDING)					
Floor Name	Total Built Up Area (Sq.mt.)	Proposed FAR Area (Sq.mt.)	Total FAR Area (Sq.mt.)	Total Consumed Additional FAR Area (Sq.mt.)	Tnmt (No.)
Ground Floor	78.22	78.22	78.22	78.22	01
First Floor	80.73	80.73	80.73	80.73	00
Terrace Floor	0.00	0.00	0.00	0.00	00
Total:	158.95	158.95	158.95	158.95	01
Total Number of Same Buildings	1				
Total:	158.95	158.95	158.95	158.95	01

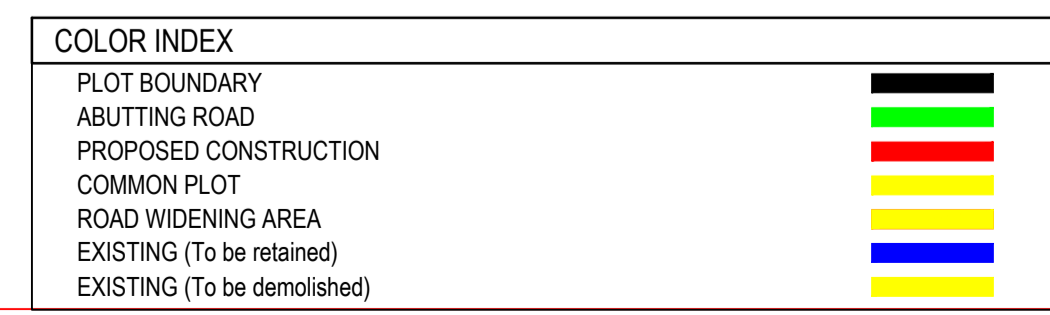

LTP NAME AND SIGNATURE			
STRUCTURAL ENG'S NAME AND SIGNATURE	BUILDER NAME AND SIGNATURE	DIGITAL SIGNATURE	
AMRIT KUMAR MAHATO CMC/DFTM/0004/2019			