

Proposal Basic Information

Proposal File No.	CMC/BP/0105/W06/2023
Owner Name	SANDHYA MOHANTI AND PRASHANT RANJAN
Khata No	37
Plot No	533
Village Name	Bhawaniapur
Use	Residential
SubUse	Bungalow/ Dwelling / Non Apartment

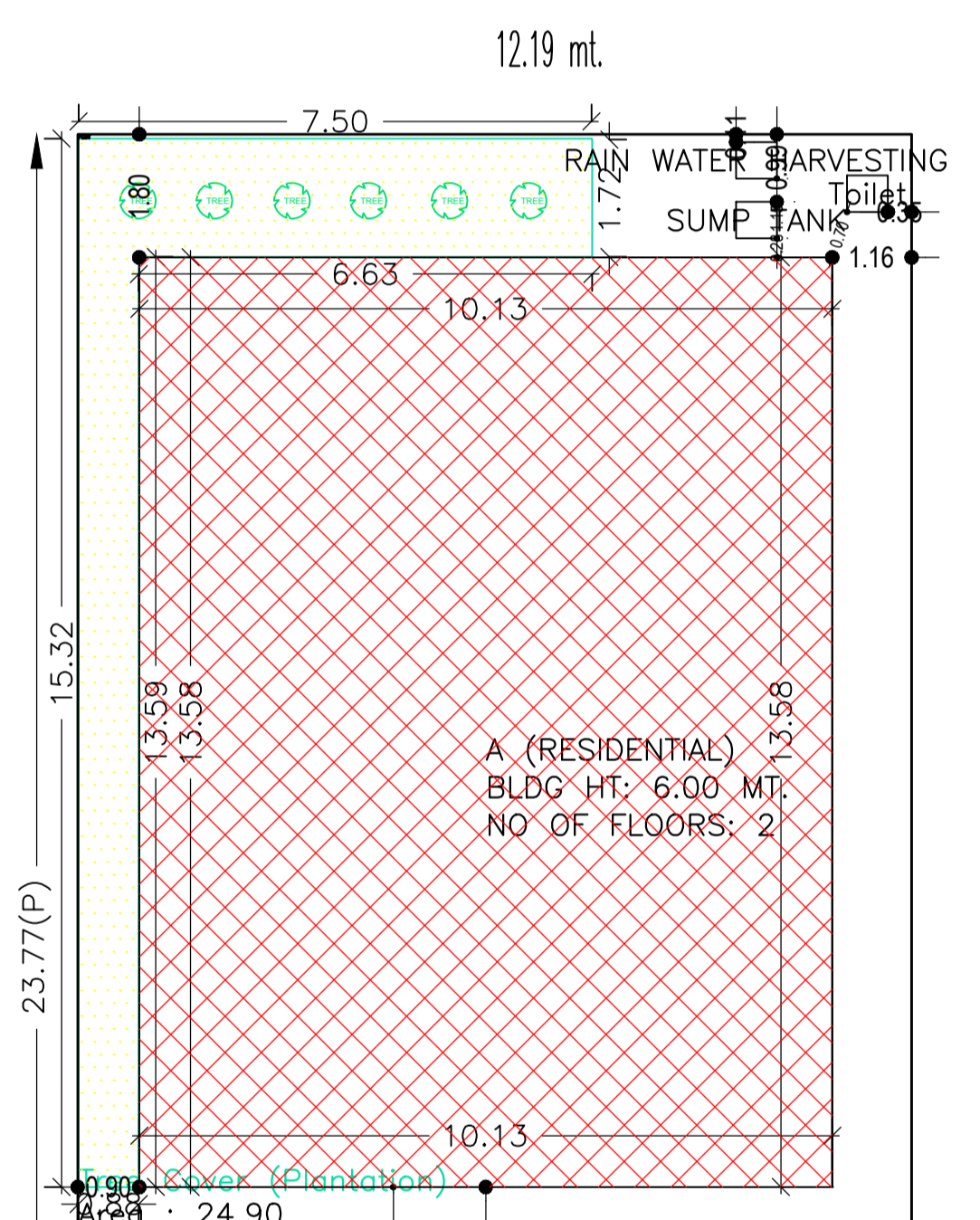

AREA STATEMENT CHAS MUNICIPAL CORPORATION	VERSION NO: 1.0.66	SQ. MT.
PROJECT DETAIL:	VERSION DATE: 16/10/2020	
Region: JHARKHAND URBAN LOCAL BODIES	Plot Use: Residential	
District: BOKARO	Plot SubUse: Bungalow/ Dwelling / Non Apartment	
Authority: CHAS MUNICIPAL CORPORATION	PlotNearbyReligiousStructure: NA	
Inward No: CMC/BP/0105/W06/2023	PlotSubPlot No: 533	
Application Type: General Proposal	North: Plot No. - VENDOR NIJJ	
Project Type: Building Permission	South: Plot No. - PART OF PLOT	
Nature of Development: New	East: Plot No. - PART OF PLOT	
Location of Development Area: Old Area	West: Road Width - ROAD	
AREA DETAILS:		
AREA OF PLOT (Minimum)	(A)	289.76
NET AREA OF PLOT(Gross Plot Area - Deduction from Gross Plot area)	(A-Deductions)	289.76
Deduction for Balance Plot Area(from Gross Plot Area)		
Common Plot		24.90
Total		24.90
BALANCE AREA OF PLOT(Net Plot Area - Recreational/Amenity space)	(A-Deductions)	264.86
PLOT AREA FOR COVERAGE(Net Plot Area)	(A-Deductions)	289.76
Plot Area for FAR (Net Plot Area + Road/Widening Area)	(A-Deductions)	289.76
COVERAGE CHECK		
Permissible Coverage area (60.00 %)		173.86
Proposed Coverage Area (47.50 %)		137.62
Total Prop. Coverage Area (47.5 %)		137.62
Balance coverage area (12.51 %)		36.24
FAR CHECK		
Perm. FAR Area (1.500)		434.64
Total Perm. FAR area		434.64
Residential FAR		275.23
Proposed FAR Area		275.23
Total Proposed FAR Area		275.23
Consumed FAR (Factor)		0.95
Balance FAR Area		159.41
BUILT UP AREA CHECK		
Total Proposed BuiltUp Area		275.24
ARCHITECT (Regd)		RAVI KUMAR
ENGINEER (Regd)		
SUPERVISOR (Regd)		SANDHYA MOHANTI AND PRASHANT RANJAN
OWNER (Regd)		
DEVELOPMENT AUTHORITY		LOCAL BODY

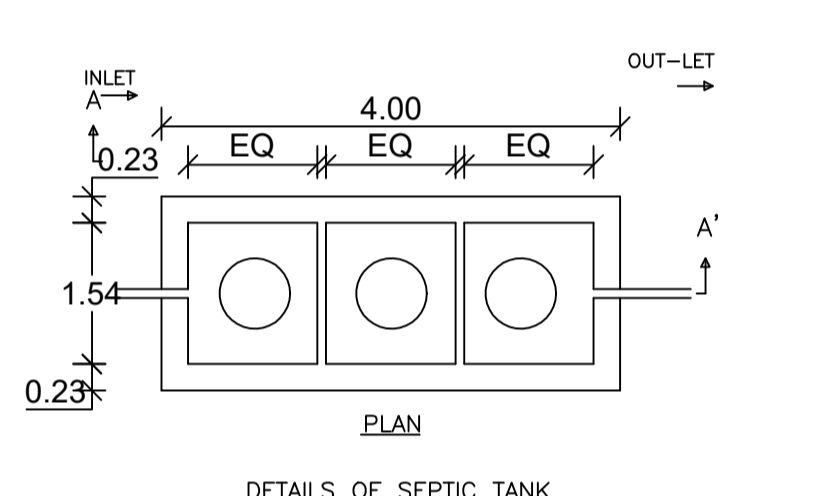
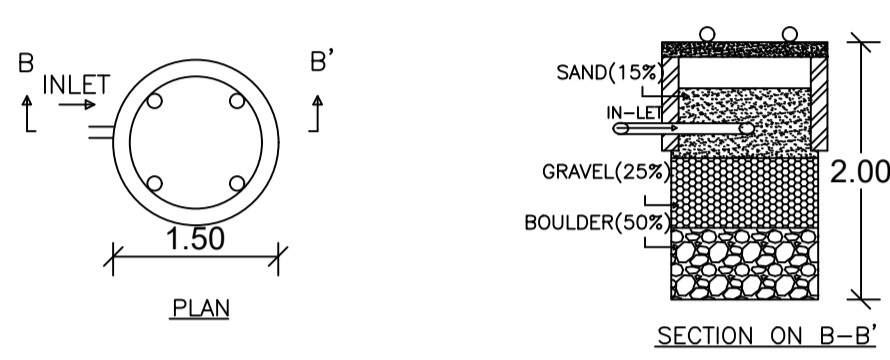
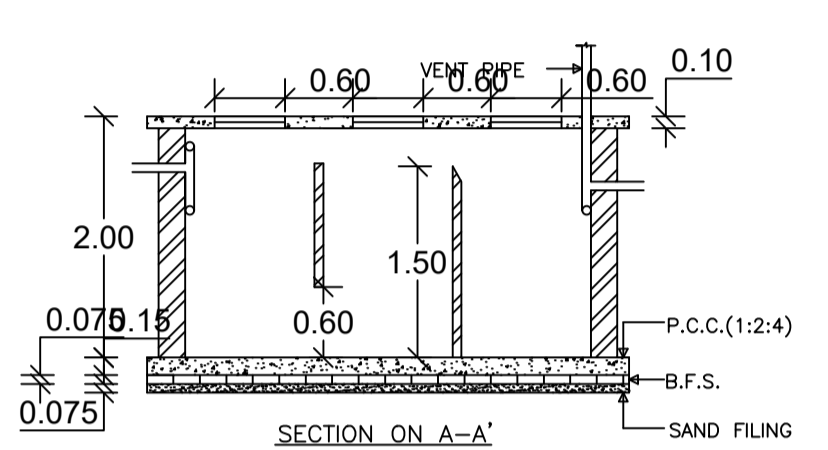
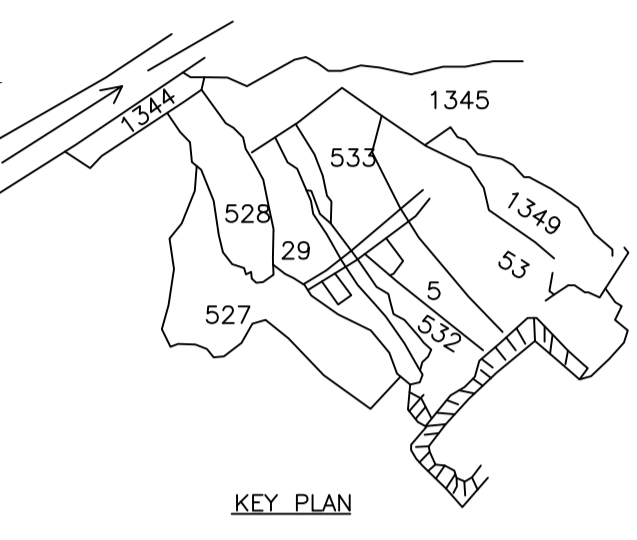
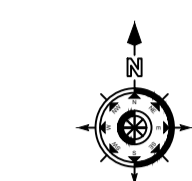
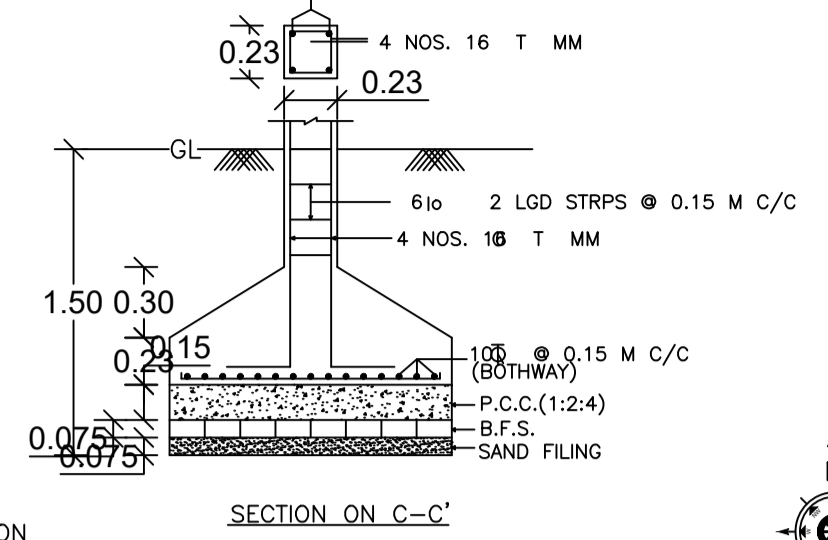
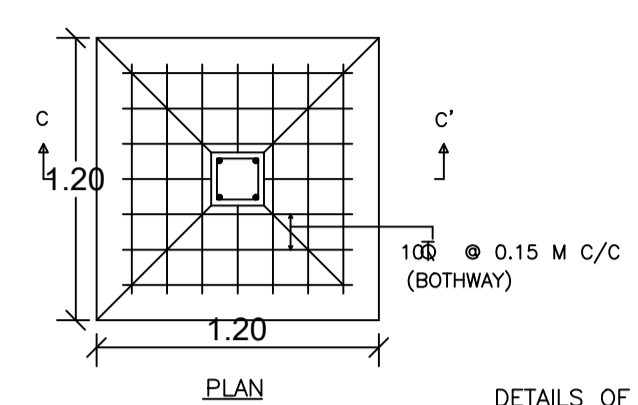
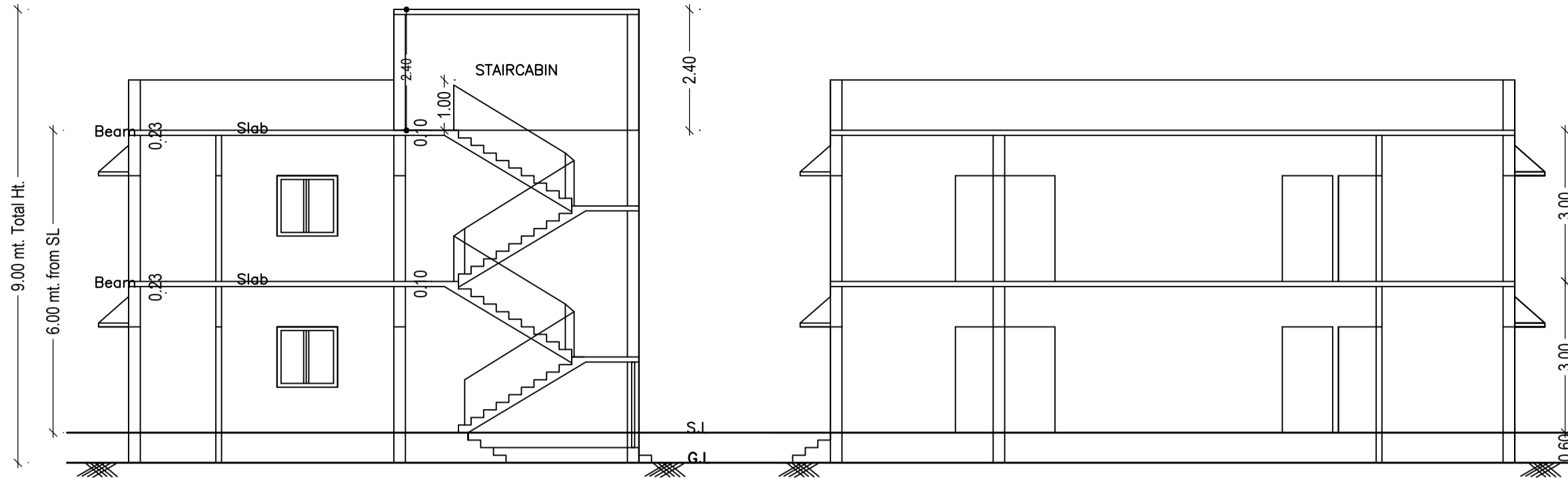
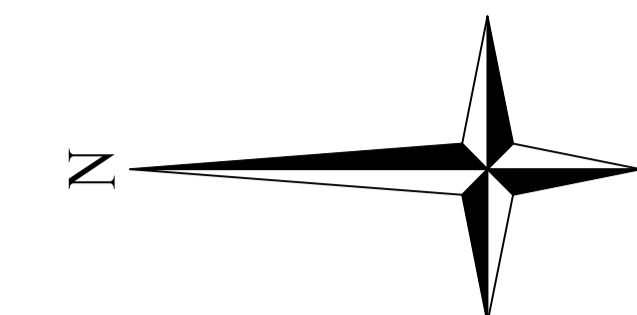
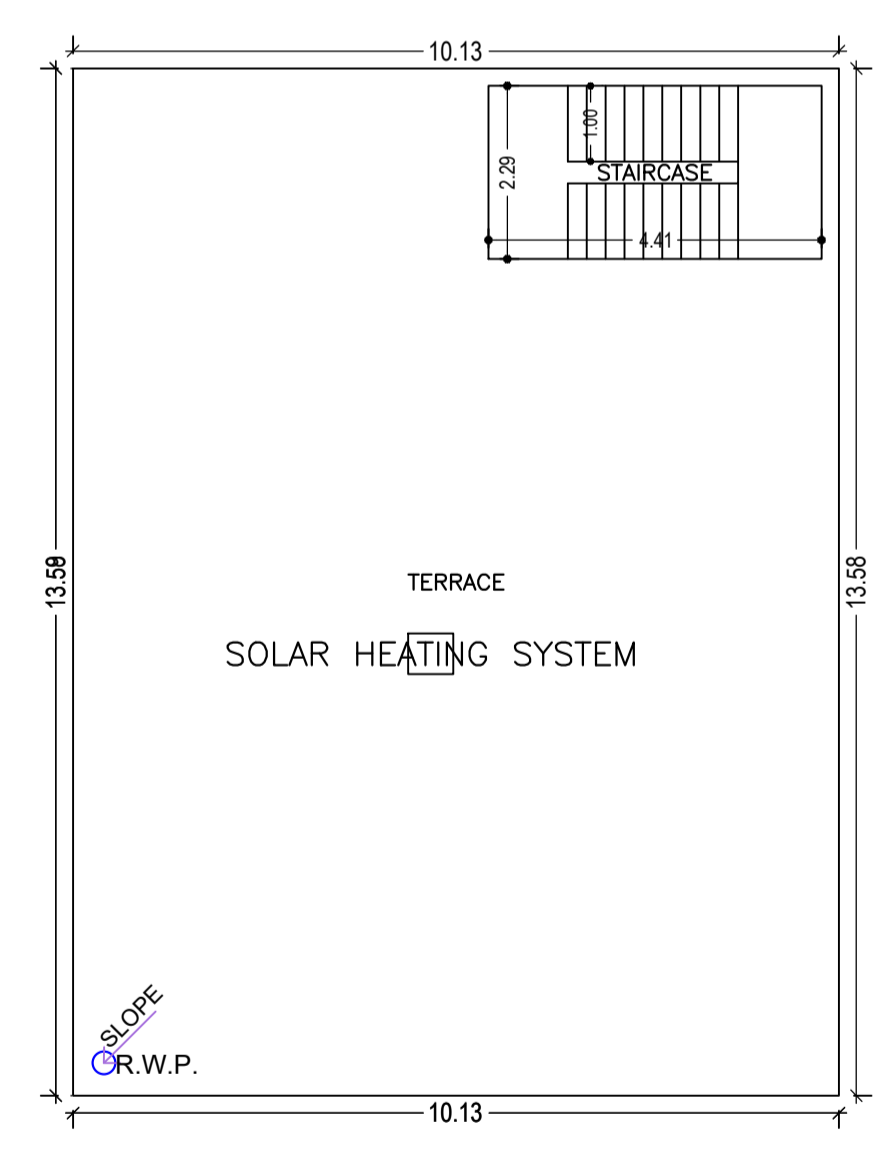
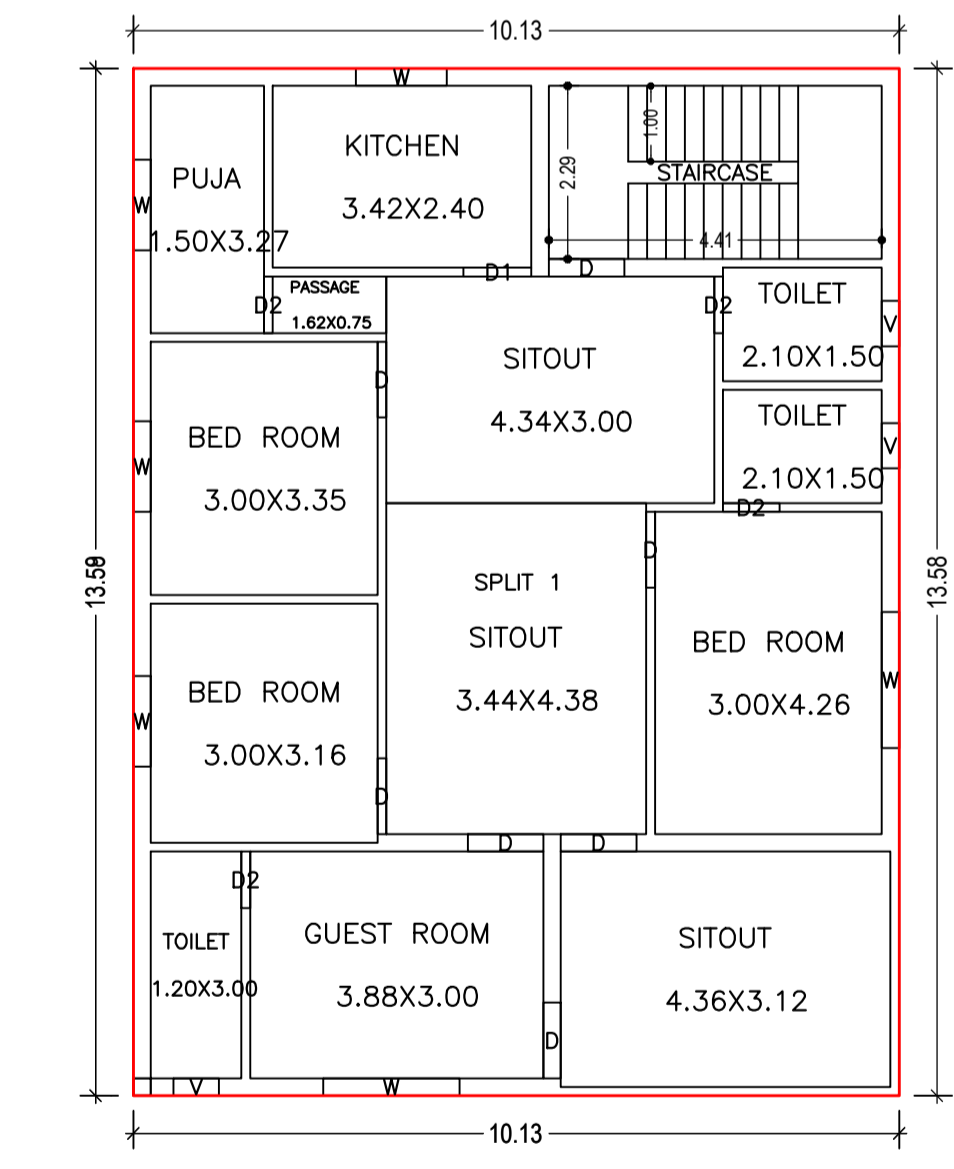
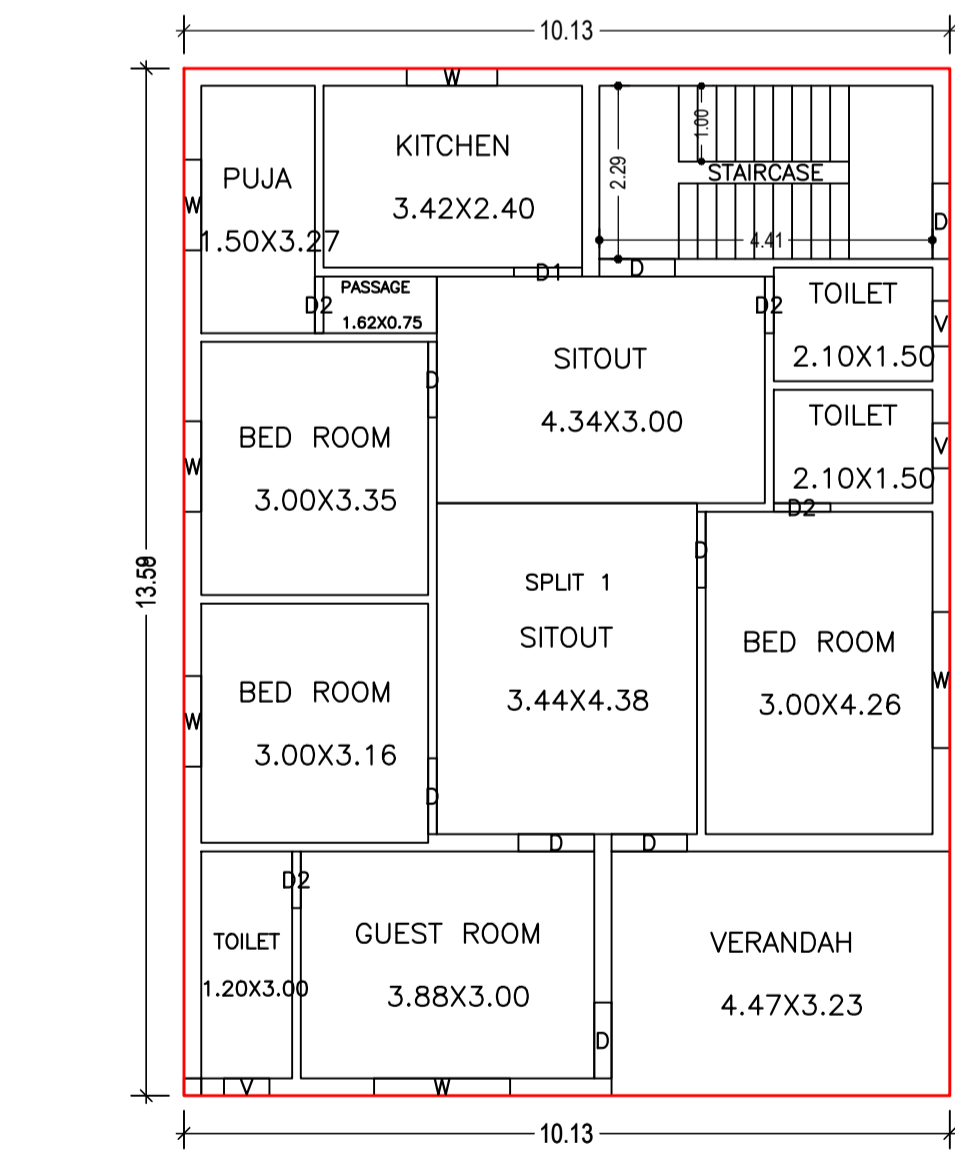

Floor Name	Building Name		Total	
	Proposed Built Up Area (Sq.mt.)	Proposed FAR Area (Sq.mt.)	Total Proposed Built Up Area (Sq.mt.)	Total FAR Area (Sq.mt.)
Ground Floor	137.62	137.62	137.62	137.62
First Floor	137.62	137.62	137.62	137.62
Terrace Floor	0.00	0.00	0.00	0.00
Total	275.24	275.24	275.24	275.24

Floor Name	Total Built Up Area (Sq.mt.)	Proposed FAR Area (Sq.mt.)	Total FAR Area (Sq.mt.)	Total Consumed Additional FAR Area (Sq.mt.)	Tnmt (No.)
Ground Floor	137.62	137.62	137.62	137.62	01
First Floor	137.62	137.62	137.62	137.62	00
Terrace Floor	0.00	0.00	0.00	0.00	00
Total	275.24	275.24	275.24	275.24	01

FLOOR	Name	UnitBUA Type	UnitBUA Area	Carpet Area	No. of Rooms	No. of Tenement
GROUND FLOOR PLAN	SPLIT 1	FLAT	275.23	275.13	13	1
	SPLIT 1	FLAT	0.00	0.00	13	0
FIRST FLOOR PLAN						
Total:			275.23	275.13	26	1

Building	No. of Same Bldg	Total Built Up Area (Sq.mt.)	Proposed FAR Area (Sq.mt.)	Total FAR Area (Sq.mt.)	Total Consumed Additional FAR Area (Sq.mt.)	Tnmt (No.)
A (RESIDENTIAL)	1	275.24	275.24	275.24	275.24	01
Grand Total :		275.24	275.24	275.24	275.24	01

SCHEDULE OF DOOR:

BUILDING NAME	NAME	LENGTH	HEIGHT	NOS
A (RESIDENTIAL)	D2	0.75	2.10	08
A (RESIDENTIAL)	D1	0.90	2.10	02
A (RESIDENTIAL)	D	1.00	2.10	14

SCHEDULE OF WINDOW/VENTILATION:

BUILDING NAME	NAME	LENGTH	HEIGHT	NOS
A (RESIDENTIAL)	V	0.60	1.20	06
A (RESIDENTIAL)	W	1.20	1.20	08
A (RESIDENTIAL)	W	1.80	1.20	04

Building USE/SUBUSE Details

Building Name	Building Use	Building SubUse	Building Structure
A (RESIDENTIAL)	Residential	Bungalow/ Dwelling / Non Apartment	Non-Highrise

COLOR INDEX

PLOT BOUNDARY	Black
ABUTTING ROAD	Green
PROPOSED CONSTRUCTION	Red
COMMON PLOT	Yellow
ROAD WIDENING AREA	Blue
EXISTING (To be retained)	Orange
EXISTING (To be demolished)	Light Blue

LTP NAME AND SIGNATURE	STRUCTURAL ENG'S NAME AND SIGNATURE	BUILDER NAME AND SIGNATURE	DIGITAL SIGNATURE
RAVI KUMAR CMC/DFTMN/024/2017			